

Field Manual
No. 23-65

HEADQUARTERS
DEPARTMENT OF THE ARMY
Washington, DC, 19 June 1991

**BROWNING MACHINE GUN
CALIBER .50 HB, M2**

CONTENTS

	page
PREFACE	iv
CHAPTER 1. INTRODUCTION	
1-1. Training Strategy.....	1-1
1-2. Description.....	1-5
1-3. Components	1-8
1-4. Ground Mounts.....	1-9
1-5. Accessories for Ground Mounts	1-12
1-6. Vehicular Mounts	1-14
1-7. Ammunition.....	1-17
CHAPTER 2. MAINTENANCE	
2-1. Safety.....	2-1
2-2. General Disassembly.....	2-2
2-3. Cleaning, Inspection, and Lubrication	2-9
2-4. Maintenance Procedures	2-12
2-5. Maintenance Under NBC Conditions.....	2-12
2-6. General Assembly.....	2-12
2-7. Function Check.....	2-17
CHAPTER 3. OPERATION AND FUNCTIONING	
3-1. Operation	3-1
3-2. Loading Procedures	3-1
3-3. Unloading Procedures.....	3-3
3-4. Cycle of Functioning.....	3-4
3-5. Left-Hand Feed	3-11
3-6. Headspace and Timing	3-12

DISTRIBUTION RESTRICTION: Approved for public release; distribution is unlimited.

***This publication supersedes FM 23-65, 19 May 1972, and TC 23-65-1, 19 September 1984 .**

	page
CHAPTER 4. PERFORMANCE PROBLEMS AND DESTRUCTION	
4-1. Malfunctions	4-1
4-2. Stoppages.....	4-1
4-3. Immediate Action.....	4-2
4-4. Remedial Action.....	4-3
4-5. Destruction Procedures	4-5
CHAPTER 5. MARKSMANSHIP TRAINING	
Section I. Planning	5-1
5-1. Objectives	5-1
5-2. Commander's Responsibilities	5-1
5-3. Phases of Training.....	5-2
5-4. Sustainment Training.....	5-2
5-5. Remedial Training.....	5-2
Section II. Fundamentals	5-3
5-6. Firing Positions	5-3
5-7. Dry Fire Training	5-6
5-8. Range Determination.....	5-12
5-9. Observation and Adjustment of Fire.....	5-16
5-10. Fire Commands	5-18
5-11. Crew Exercises.....	5-22
5-12. Machine Gun Fundamental Skills Test	5-36
Section III. Basic Marksmanship	5-36
5-13. Concept of Zeroing/Targeting.....	5-36
5-14. 10-Meter Firing Exercise	5-41
5-15. Transition Day Firing Exercise	5-41
5-16. NBC Firing	5-41
5-17. Night Fire Exercise	5-41
Section IV. Advanced Gunnery	5-41
5-18. Objectives	5-42
5-19. Tracking and Leading Exercises.....	5-42
5-20. Mounted Firing Exercise	5-45
5-21. Mounted NBC Firing Exercise.....	5-45
5-22. Predetermined Firing Exercise.....	5-45
CHAPTER 6. COMBAT TECHNIQUES OF FIRE	
Section I. Fundamentals	6-1
6-1. Characteristics of Fire	6-1
6-2. Classes of Fire	6-3
Section II. Fire Control	6-7
6-3. Methods of Fire Control	6-8
6-4. Targets and Their Engagement	6-8
6-5. Overhead Fire	6-14
6-6. Defilade Positions.....	6-18
6-7. Methods of Laying the Gun for Defilade Firing	6-20
6-8. Final Protective Fires	6-21
6-9. Application of Fire.....	6-22
6-10. Fire Adjustment	6-23
6-11. Antiaircraft Gunnery	6-25

	Page
Section III. Limited Visibility Conditions	6-26
6-12. Difficulties	6-26
6-13. Terminology.....	6-26
6-14. Target Engagement.....	6-27
6-15. Fire Control.....	6-28
6-16. Preplanned Fires	6-28
6-17. NBC Considerations.....	6-29
CHAPTER 7. TRAIN THE TRAINER PROGRAM	
7-1. Concept	7-1
7-2. Trainer Certification Program.....	7-2
7-3. Responsibilities and Duties of the Trainer	7-3
APPENDIX A. SAFETY	A-1
APPENDIX B. TRAINING AIDS AND DEVICES	B-1
APPENDIX C. RANGES AND TRAINING EXERCISES	C-1
APPENDIX D. FIGHTING POSITIONS	D-1
APPENDIX E. RANGE CARDS	E-1
APPENDIX F. AERIAL DEFENSE	F-1
GLOSSARY	Glossary-1
REFERENCES	References-1
INDEX	Index-1

PREFACE

This manual is intended to provide technical information, training techniques, and guidance on the Browning machine gun caliber .50 HB, M2. Unit leaders and the designated gunners will find this information invaluable in their efforts to successfully integrate this automatic weapon into their combat operation. All instruction can be given either on the range or in the vicinity (concurrent training stations).

The material contained herein is applicable without modification to nuclear and conventional warfare.

Trainers must see that safety procedures are observed at all times. Commanders, trainers, and individual students must all remember that safety is everyone's responsibility. All training should be conducted as though the weapon is fully loaded. At no time while using this manual will speed or accuracy override safety procedures. Safe training is good training.

The proponent of this publication is US Army Infantry School. Send comments and recommendations on DA Form 2028 (Recommended Changes to Publications and Blank Forms) directly to Commandant, US Army Infantry School, ATTN: ATSH-IN-S3, Fort Benning, GA 31905-5593.

<p>Unless this publication states otherwise, masculine nouns and pronouns do not refer exclusively to men.</p>

CHAPTER 1

INTRODUCTION

The procedures and methods used in Army machine gun marksmanship are based on the concept that soldiers must be skilled gunners who can effectively apply their firing skills in combat. The basic firing skills and exercises outlined in this manual must be a part of every unit's machine gun training program. The soldiers' proficiency depends on proper training and application of basic gunnery fundamental, which are taught in a progressive program to prepare gunners for combat.

1-1. TRAINING STRATEGY

Training strategy is the overall concept for integrating resources into a program to train individual and collective skills needed to perform a unit's wartime mission.

a. Training strategies for marksmanship are implemented in TRADOC institutions (NCOES, basic and advanced officer's courses) and in units. The overall training strategy is multifaceted and is inclusive of the specific strategies used in institution and unit programs. Also included are the supporting strategies that use resources such as publications, ranges, ammunition, training aids, devices, simulators, and simulations. These strategies focus on developing critical soldier skills, and on leader skills that are required for the intended outcome.

b. Two primary components compose the training strategies: initial training and sustainment training. Both may include individual and collective skills. Initial training is critical because a task that is taught correctly and learned well is retained longer. Well-trained skills can be more quickly regained and sustained if an interim of nonuse occurs. The more difficult and complex the task, the harder it is to sustain the skill. Personnel turnover is a main factor in decay of collective skills, since the loss of critical team members requires retraining to regain proficiency. If a long period elapses between initial and sustainment training sessions or training doctrine is altered, retraining maybe required.

c. The training strategy for caliber .50 MG marksmanship begins in selected resident training and continues in the unit. An example of this overall process is illustrated in Figure 1-1 and provides a concept of the

flow of unit sustainment training. The soldiers graduating from selected resident training courses have been trained to maintain their MGs and to hit a variety of targets. They have learned range determination, target detection, application of marksmanship fundamentals, and other skills needed to engage a target. Task training during these courses may lead to qualification.

d. Training continues in units on the basic skills taught in combat arms. Additional skills, such as suppressive fire and supporting fire, are trained and then integrated into collective training exercises, which include platoon and squad live-fire STXs. (A unit-marksmanship training program is explained in Chapter 5.) The strategy for sustaining the basic marksmanship skills taught in combat arms is periodic preliminary instruction, followed by qualification range firing. However, a unit must set up a year-round program to sustain skills. Key elements include training of trainers and refresher training of nonfiring skills.

e. Additional skills trained in the unit include techniques for employment, suppressive fires, night fire, MOPP firing, and moving targets. Related soldier skills of camouflage, cover and concealment, maneuver, and preparation and selection of a fighting position are addressed in STP 21-24-SMCT, which must be integrated into tactical training.

f. In the unit, individual and leader proficiency of marksmanship tasks are integrated into collective training to include squad, section, and platoon drills and STXs. The collective tasks in these exercises, and how they are planned and conducted, are in the MTP and battle drill books for each organization. Based on the type organization, collective tasks are evaluated to standard and discussed during leader and trainer after-action reviews. Objective evaluations of both individual and unit proficiency provide readiness indicators and future training requirements.

g. A critical step in the Army's overall marksmanship training strategy is to train the trainers and leaders first. Leader courses and unit publications develop officer and NCO proficiencies necessary to plan and conduct marksmanship training and to evaluate the effectiveness of unit marksmanship programs. Training support materials are provided by the proponent schools to include field manuals, training aids, devices, simulators, and programs that are doctrinal foundations and guidance for training the force.

h. Once the soldier understands the weapon and has demonstrated skill in zeroing, additional live-fire training and a target acquisition exercise at various ranges are conducted. Target types and scenarios of increasing difficulty must be mastered to develop proficiency.

i. Initial individual training culminates in the soldier's proficiency assessment, which is conducted on a transition/record fire range. This evaluation also provides an overview of unit proficiency and training effectiveness.

j. Unit training programs maintain the soldiers' proficiency level. The ultimate goal of a unit marksmanship program is to maintain well-trained gunners so a unit can survive and win on the battlefield. The trainer must realize that qualification is not an end, but a step toward reaching this combat requirement. (See Figure 1-1.)

(1) To reach this goal, the gunner must be able to position and use his weapon under the following combat conditions:

- Enemy personnel are seldom visible except when assaulting.
- Most combat fire must be directed at an area where the enemy has been detected or where he is suspected of being located but cannot be seen. Area targets consist of objects or outlines of men irregularly spaced along covered and concealed areas (ground folds, hedges, or borders of woods).
- Most combat targets can be detected by smoke, flash, dust, noise, or movement and are visible only for a moment.
- Some combat targets can be engaged by using nearby objects as reference points.
- The nature of the target and irregularities of terrain and vegetation may require a firer to use a variety of positions in addition to the prone or supported position to fire effectively on the target. In a defensive situation, the firer usually fires from a supported position.
- Most combat targets have a low contrast outline and are obscure. Therefore, choosing an aiming point in elevation is difficult.
- Time-stressed fire in combat can be divided into three types: a single, fleeing target that must be engaged quickly; distributed targets engaged within the time they remain available; and a surprise target that must be engaged at once with accurate, instinctive fire.

(2) The unit's program must provide fundamental training to sustain and improve the skills and proficiency the soldier has attained during his basic marksmanship training. Once basic skills have been mastered, these must be improved by conducting new or advanced individual and collective training. The program must develop collective firing skills by incorporating marksmanship into tactical exercises. This training must maintain the soldier's confidence in the weapon and his skills. A soldier's

survival may depend on his ability to defend himself or other members of the unit. Therefore, individual and collective firing skills must support the expected battlefield conditions and the unit's combat mission.

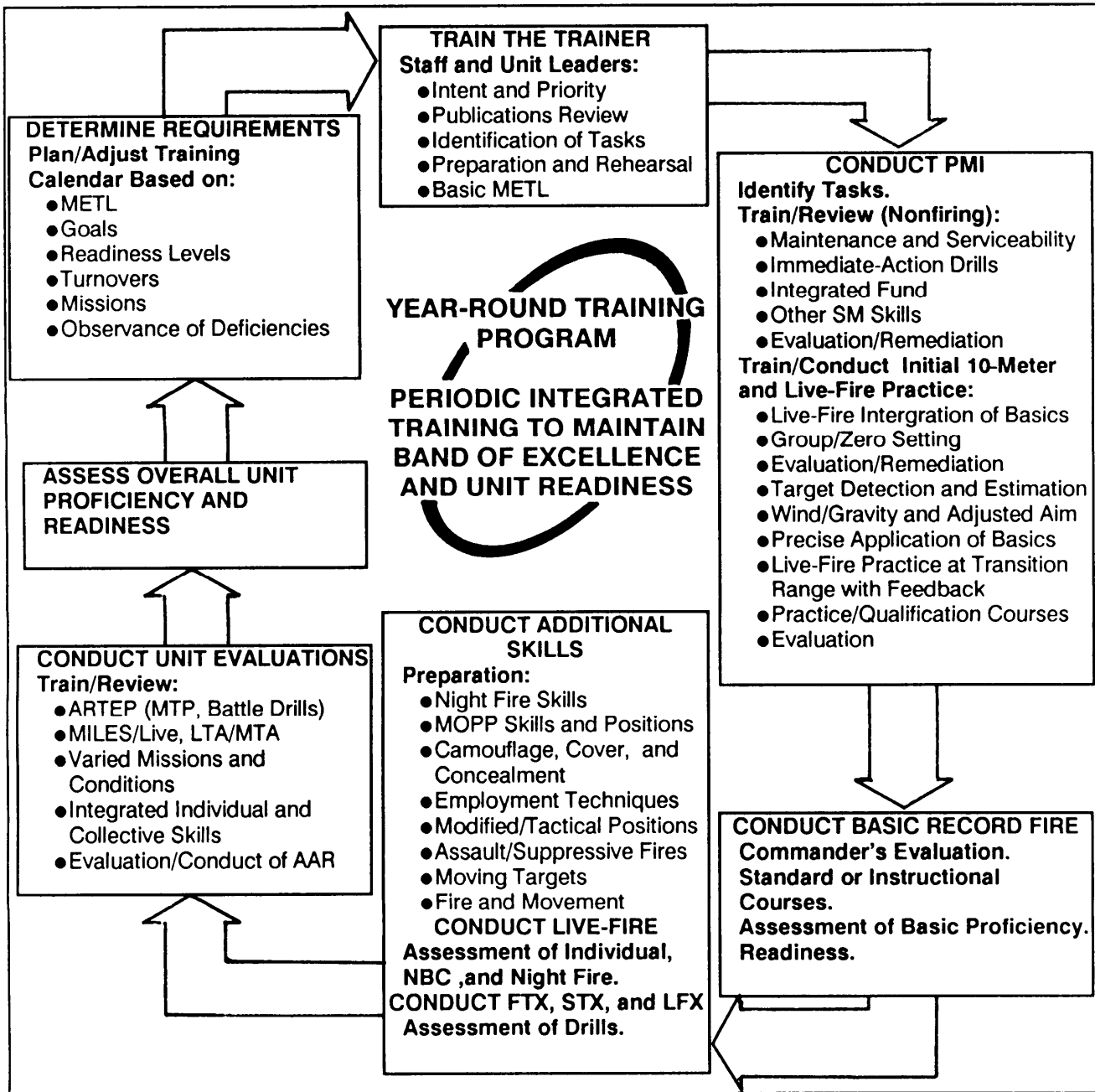

Figure 1-1. Unit marksmanship sustainment strategy.

(3) A unit's marksmanship program must be battlefield oriented. It must be based upon several individual combat tasks as well as organizational, operational, or contingency missions. It must have available resources such as ammunition, time, ranges, and qualified trainers. This manual provides the information a unit commander needs to develop an effective marksmanship program for his unit requirements.

(4) General marksmanship, training knowledge, and accurate firing are acquired skills that perish easily. Skill practice should be conducted for short periods throughout the year. Most units have a readiness requirement that all soldiers must zero their MGs within a certain time after unit assignment. Also, soldiers must confirm the zero of their assigned MGs before conducting a qualification firing.

1-2. DESCRIPTION

The Browning machine gun caliber .50 HB, M2 (Figure 1-2) is a belt-fed, recoil-operated, air-cooled, crew-served machine gun. The gun is capable of single shot, as well as automatic fire, and operates on the short recoil principle.

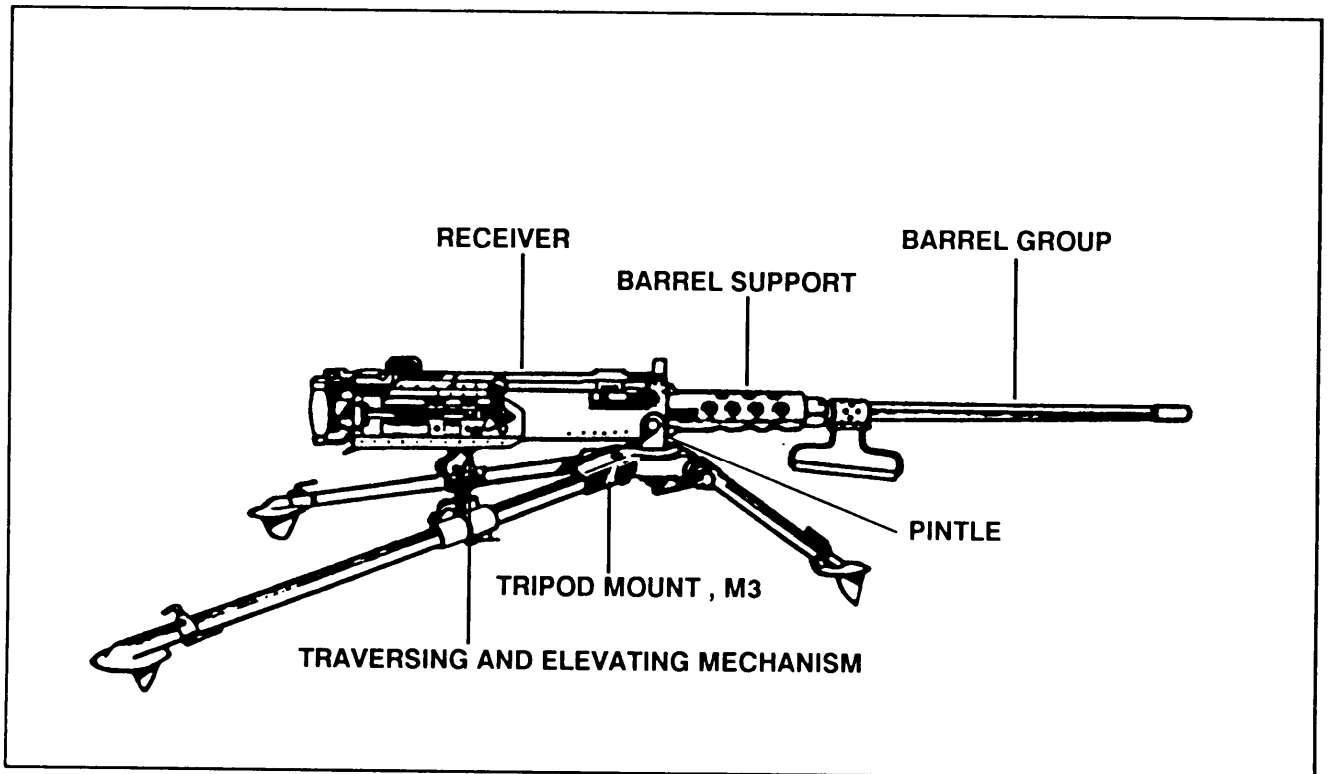

Figure 1-2. Browning machine gun.

a. The machine gun is capable of being fed from either the right or left by repositioning certain parts. The weapon has nonfixed headspace that must be set. Timing must also be adjusted to cause the gun to fire slightly out of battery to prevent damage to moving parts. The force for recoil operation is furnished by expanding powder gases, which are controlled by various springs, cams, and levers. Maximum surface of the barrel and receiver are exposed to permit air cooling. Perforations in the barrel support allow air to circulate around the breach end of the barrel and help in cooling the parts. A heavy barrel is used to retard early overheating.

b. The gun has a leaf-type rear sight (Figure 1-3), graduated in both yards and mils. The scale ranges from 100 to 2,600 in yards, and from 0 to 62 in mils. The windage knob-permits deflection changes to right or left of center. The front sight is a fixed blade type with cover (Figure 1-4).

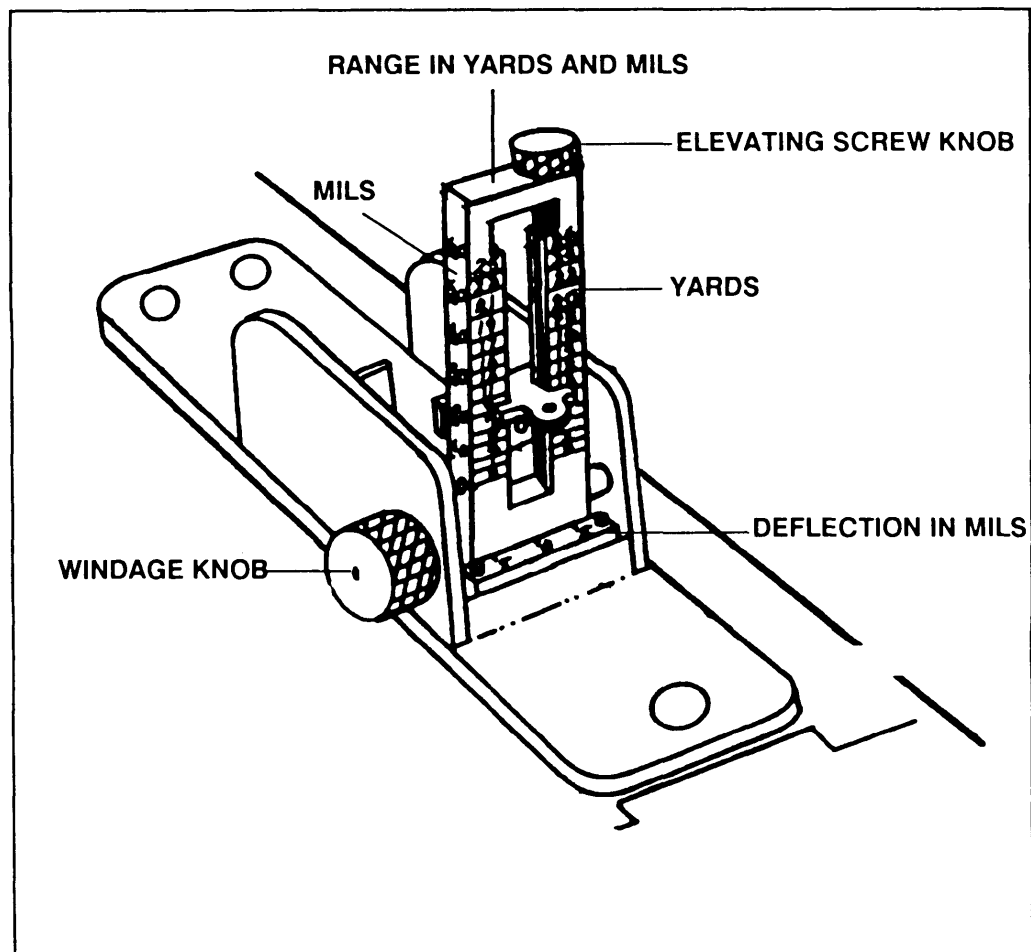

Figure 1-3. Leaf type rear sight.

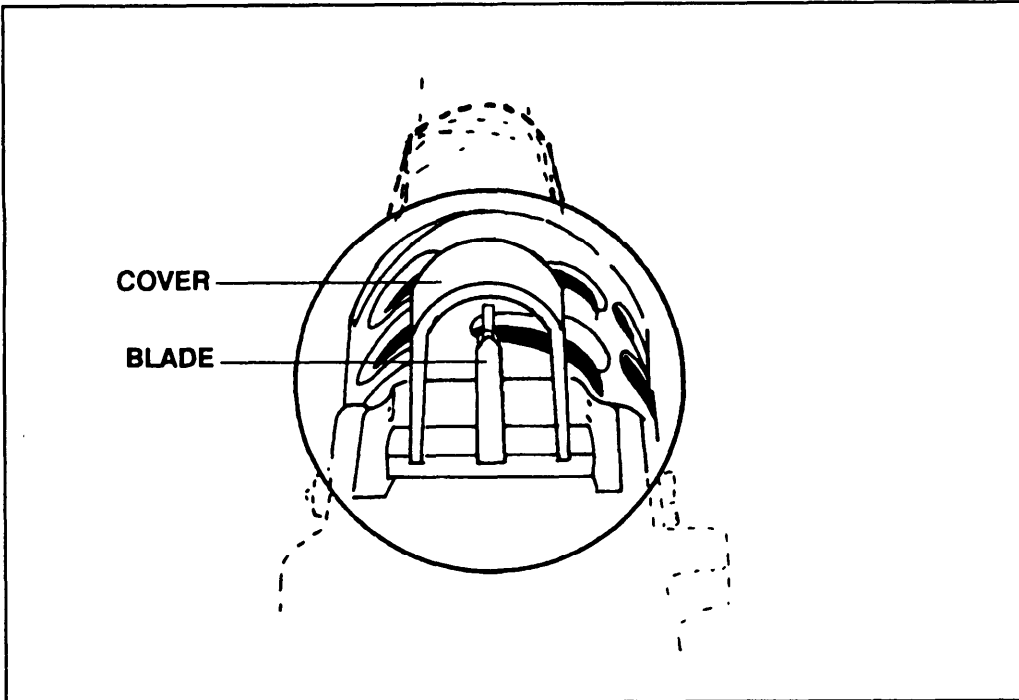

Figure 1-4. Front sight, cover, and blade.

c. Table 1-1 provides the general data on the caliber .50 MG.

Weight (approx)	84 pounds
Weight of barrel	24 pounds
Length of gun	65.13 inches
Length of barrel	45 inches
Length of rifling (approx)	41.88 inches
Number of lands and grooves	8
Twist, right-hand	one turn in 15 inches
Feed	link-belt
Operation	recoil
Cooling	air
Muzzle velocity (approx)	3,050 feet per second
Rate of fire (cyclic)	450-550 rounds per minute
Maximum range (approx)	7,440 yards or 6,764 meters
Maximum effective range (approx)	2,000 yards or 1,830 meters
Area targets	1,830 meters
Point targets	
Single shot	1,500 meters

Table 1-1. General data.

1-3. COMPONENTS

The major components of the caliber .50 MG and their purposes are shown in Figure 1-5 and Table 1-2.

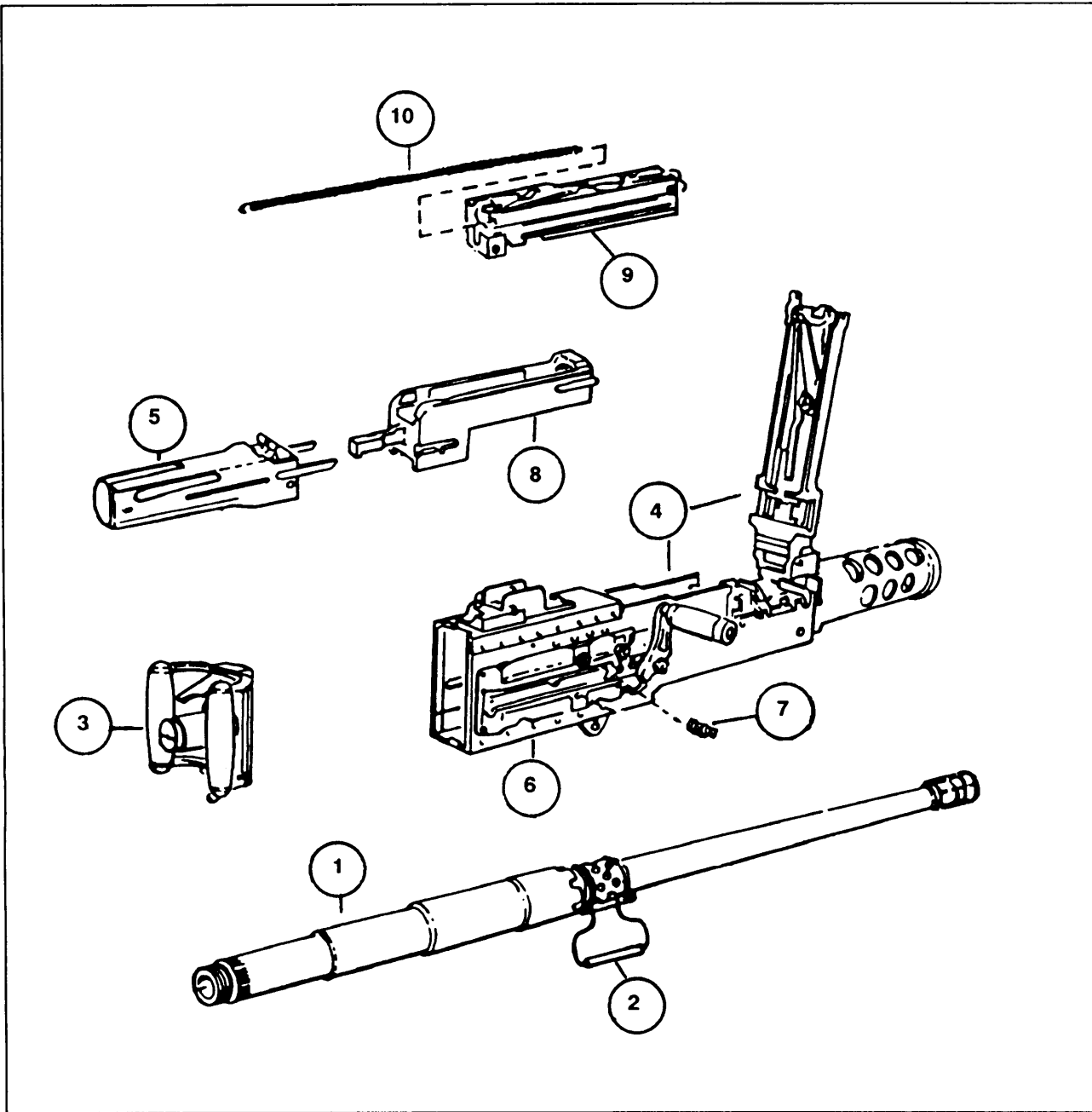

Figure 1-5. Components of the caliber .50 MG.

COMPONENTS	PURPOSES
1. Barrel Group	Houses cartridges for firing; directs projectile.
2. Carrier Assembly	Provides handle to carry barrel and to remove the barrel from the receiver.
3. Backplate Group	Houses the trigger, bolt latch release, buffer tube sleeve, and the left and right spade grips.
4. Receiver Group	Serves as a support for all major components; houses action of weapon, which controls functioning of weapon.
5. Bolt Group	Provides feeding, chambering, firing, and extracting, using the propellant gases and recoil spring for power.
6. Cover Group	Feeds linked belt ammunition; positions and holds cartridges in position for extracting, feeding, and chambering.
7. Bolt Stud	Provides a means to move the bolt to the rear with the retracting slide handle.
8. Barrel Extension Group	Secures the barrel to the recoiling parts.
9. Barrel Buffer Body	Assists in recoil and counterrecoil of the bolt group.
10. Driving Spring Rod Assembly....	Drives the bolt forward when the bolt latch release is depressed.

Table 1-2. Components and their purposes.

1-4. GROUND MOUNTS

The two principal ground mounts used with the caliber .50 machine gun are the tripod mount, M3, and the antiaircraft mount, M63. The tripod mount, M3, is a ground mount designed for use against ground targets. The antiaircraft mount, M63, is a ground mount principally designed for use against aerial targets. Its use against ground targets is limited because the mount tends to be unstable when the gun is fired at low angles.

a. **Tripod Mount, M3.** The M3 mount is the standard ground mount of the caliber .50 machine gun (Figure 1-6). It is a folding tripod with three, telescopic, tubular legs connected at the tripod head. Each leg ends in a

metal shoe that can be stamped into the ground for greater stability. The two trail legs are joined together by the traversing bar. The traversing bar serves as a support for the traversing and elevating mechanism, which in turn supports the rear of the gun. The tripod head furnishes a front support for the mounted gun that is further supported by the short front leg. When the tripod is emplaced on flat terrain with all extensions closed, the adjustable front leg should form an angle of about 60 degrees with the ground. This places the gun on a low mount about 12 inches above the ground. To raise the tripod farther off the ground, extend the telescopic front and trail legs enough to keep the tripod level and maintain the stability of the mount.

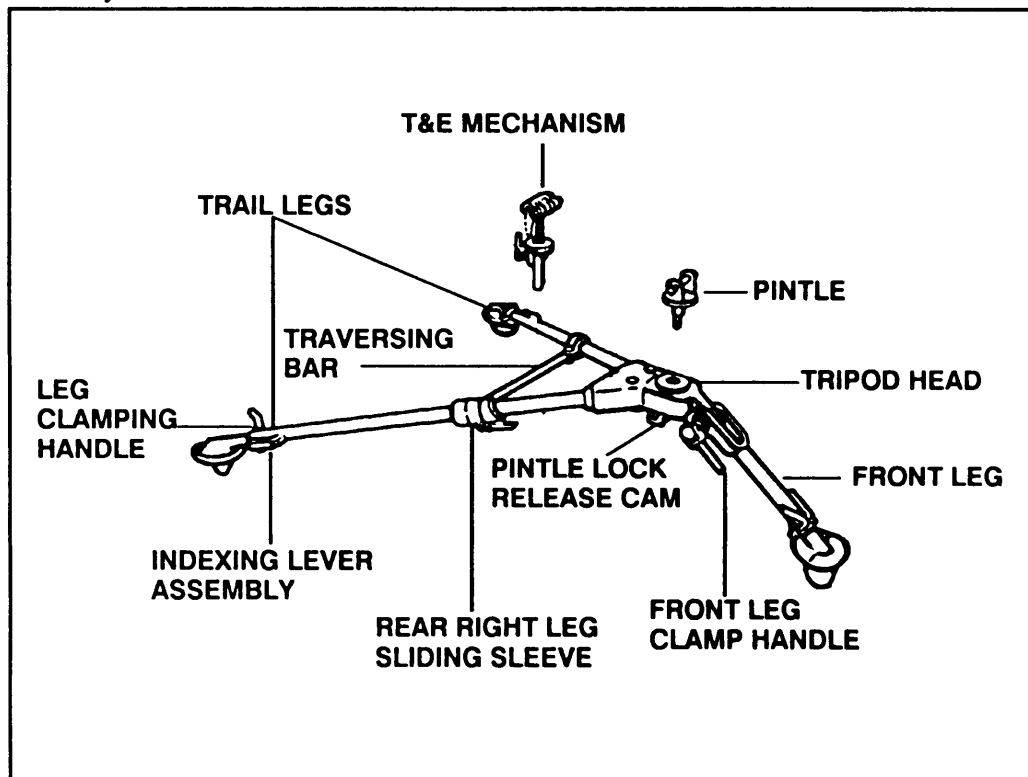

Figure 1-6. M3 tripod mount.

- (1) *To set the tripod trail legs –*
 - (a) Unscrew the leg-clamping handle, press down on the indexing lever, and extend the leg to the desired length.
 - (b) Align the indexing lever stud with one of the holes in the tripod leg extension.
 - (c) Release the pressure on the indexing lever, allowing the stud to fit the desired hole. Tighten the leg-clamping handle.

- (2) *To set the front leg of the tripod-*
- (a) Turn the front leg clamp handle counterclockwise to loosen the front leg.
 - (b) Adjust the leg to the desired angle and tighten the front leg clamp.
 - (3) To secure the tripod legs, stamp the metal shoe on each tripod leg into the ground. Sandbag each leg to stabilize the M2 for firing.

b. **Antiaircraft Mount, M63.** The antiaircraft mount (Figure 1-7) is a four-legged, low silhouette, portable mount used for antiaircraft fire. Table 1-3 lists the general data pertaining to the M63.

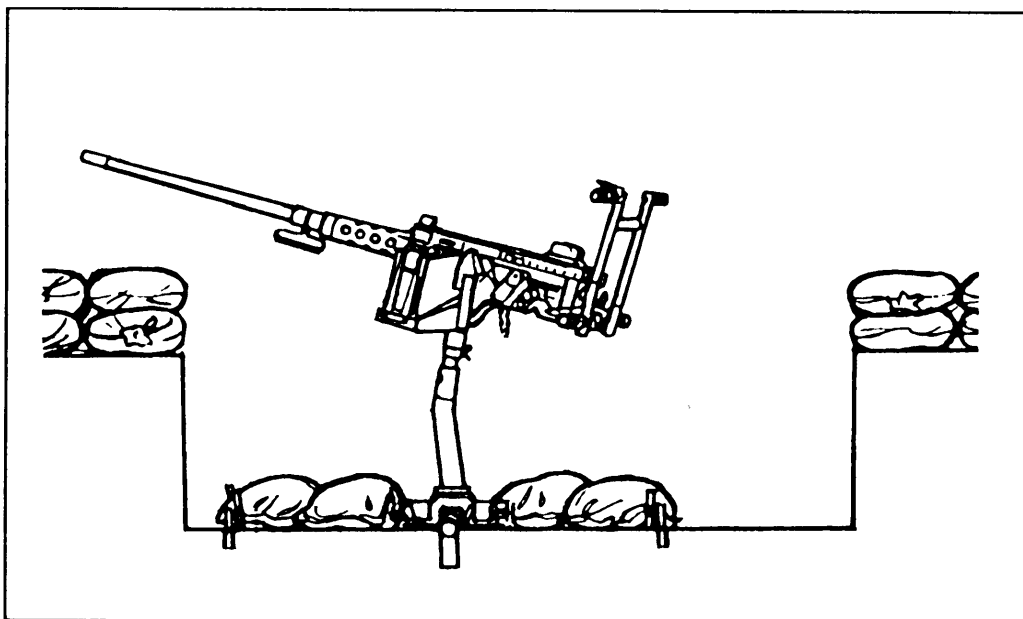

Figure 1-7. Antiaircraft mount, M63.

WEIGHTS:	
Overall	144 pounds
Four legs	24 pounds
Base assembly	54 pounds
Elevator assembly	12 pounds
Cradle assembly	44 pounds
Ammunition box-tray assembly	10 pounds
HEIGHT OVERALL	42 inches
LENGTH OF LEG	24 inches
DIAMETER OF BASE (WITH LEG ASSEMBLED).....	52 inches
MAXIMUM ELEVATION	85 degrees
MAXIMUM DEPRESSION	29 degrees
MAXIMUM TRAVERSE	360 degrees

Table 1-3. M63 general data.

1-5. ACCESSORIES FOR GROUND MOUNTS

The following paragraph explains the functions of the traversing and elevating mechanism and pintle used in the mounting of the machine gun when used in the ground configuration.

a. **Traversing and Elevating Mechanism.** The T&E mechanism (Figure 1-8) is used to engage preselected target areas at night or during limited visibility conditions. Record direction and elevation readings from the traversing bar and T&E mechanism. Record all readings in mils.

(1) The traversing mechanism consists of a traversing bar, slide, and screw assembly.

(a) The traversing bar, graduated in 5-roil increments, fits between the trail legs of the tripod. The traversing slide and screw assembly are clamped in place on the traversing bar by the traversing slide lock lever. When the traversing slide is locked to the traversing bar, the traversing handwheel should be centered. The traversing slide is properly mounted when the lock lever is to the rear and the traversing handwheel is positioned to the left.

(b) To make changes in direction, loosen the traversing slide lock lever and move the slide along the traversing bar. This permits traverse of 400 mils left or right of the zero index in the center of the traversing bar. Readings on the traversing bar are taken from the left side of the traversing slide. For changes of 50 mils or less in deflection, turn the traversing handwheel of the screw assembly. This allows a traverse of 50 mils left or right of center. One click in the traversing handwheel signifies 1 mil change in direction.

(2) The elevating mechanism consists of an upper and lower elevating screw.

(a) It is connected to the gun by inserting the quick release pin assembly through the holes in the upper elevating screw yoke and the rear mounting lugs of the receiver. A scale, graduated in mils, is fitted to the upper screw to indicate elevation. This scale is marked to show 250 mils in depression and 100 mils in elevation from the zero setting.

(b) The elevating handwheel is graduated in 1-mil increments up to 50 mils, and is fastened to the elevating screw by a screw lock. This synchronizes the handwheel graduations with those on the upper elevating screw. A spring-actuated index device produces a clicking sound when the handwheel is turned. Each click equals 1 mil change in elevation. The handwheel is turned clockwise to depress the barrel and counterclockwise to elevate.

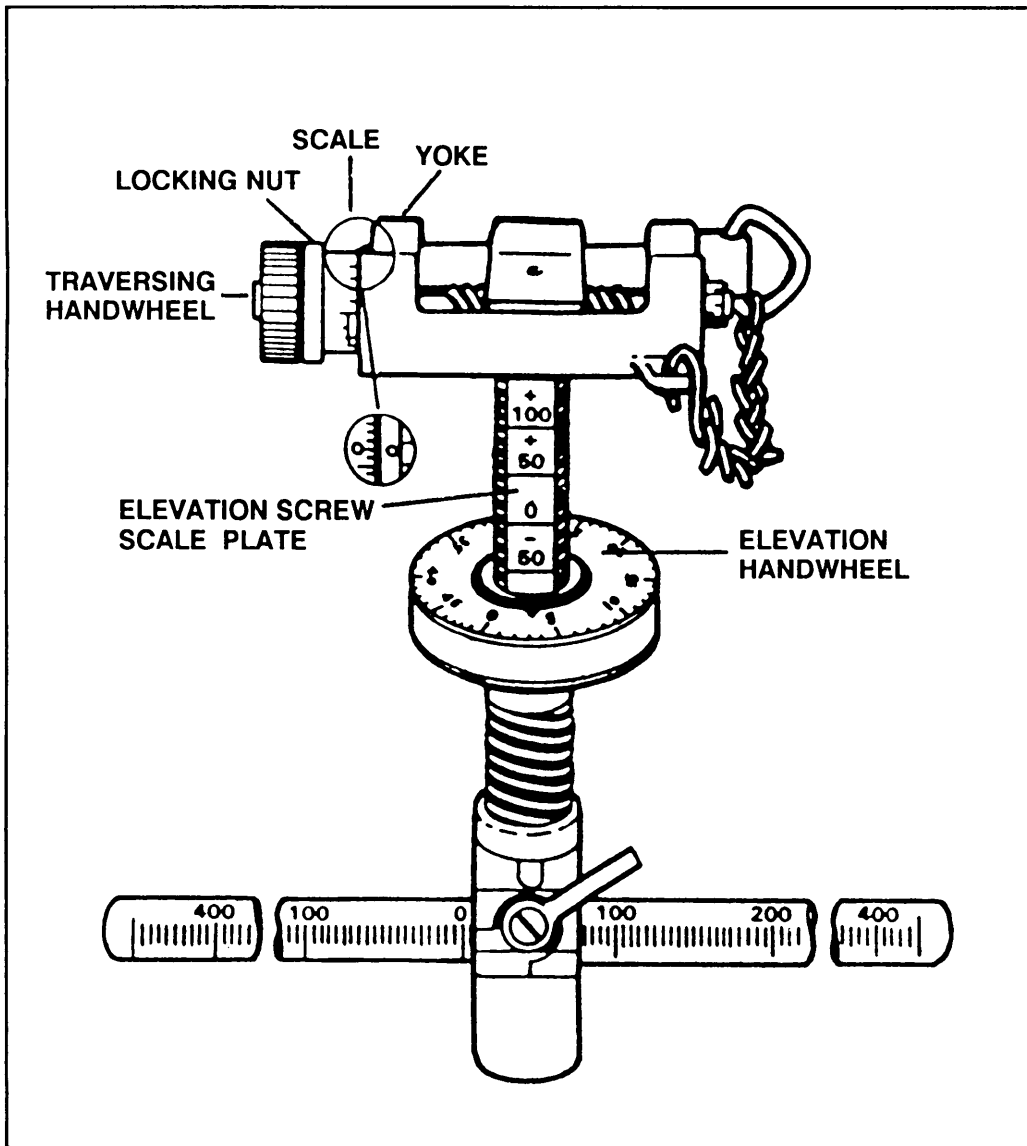

Figure 1-8. Traversing and elevating mechanism.

b. **Pintle.** The gun is connected to the tripod mount, M3, by a pintle (Figure 1-9, page 1-14). This pintle is semipermanently attached to the machine gun by a pintle bolt through the front mounting hole in the receiver. The tapered stem of the pintle seats in the tripod head. It is held secure by a pintle lock and spring. To release the pintle, raise the pintle lock, releasing the cam. The weight of the pintle and traversing and elevating mechanism are considered as part of the total weight of the tripod mount, M3 (44 pounds).

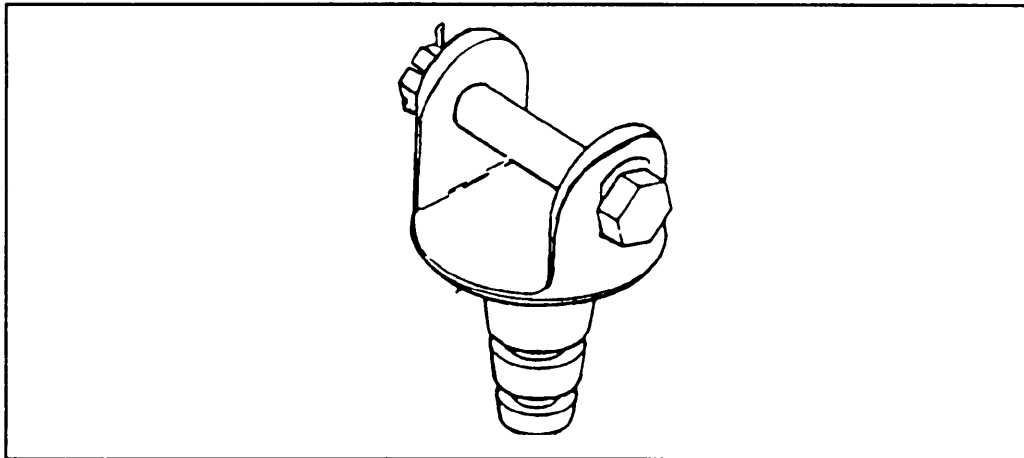

Figure 1-9. Pintle.

1-6. VEHICULAR MOUNTS

The four principal vehicular mounts used with the caliber .50 machine gun are the truck mount, M36; the pedestal truck mount, M31C and M24A2; the commander's cupola, M113 armored personnel carrier; and the MK64 gun cradle.

a. **Truck Mount, M36.** This mount consists of a cradle with a roller carriage on a circular track (Figure 1-10). The cradle can be rotated in the pintle sleeve of the carriage and can be adjusted for elevation. The carriage is guided on the track by rollers. The track is secured to the vehicle by supports.

(1) To move the gun in elevation on the M36 mount, remove the cradle locking pin and place it in the carriage handle; grasp the spade grips and elevate or depress as desired. The gun is also moved in traverse by pressure on the spade grips.

(2) To move the gun on the track, raise the brake handle lever until it is retained by the brake detent plungers. The cradle may then be moved on the track by applying pressure on the carriage handle.

b. **Pedestal Truck Mount, M31C.** Pedestal mounts are component assemblies designed for installation on the 1/4-ton vehicles to support a machine gun mount. They are composed of a pintle socket, pintle clamping screw column, and braces (Figure 1-11).

c. **Armored Vehicle Cupola Mount.** A caliber .50 machine gun and mount are installed in the gun support on the commander's cupola of an M1 13 armored personnel carrier. The machine gun can be traversed 360 degrees, elevated 53 degrees, and depressed 21 degrees maximum (Figure 1-12).

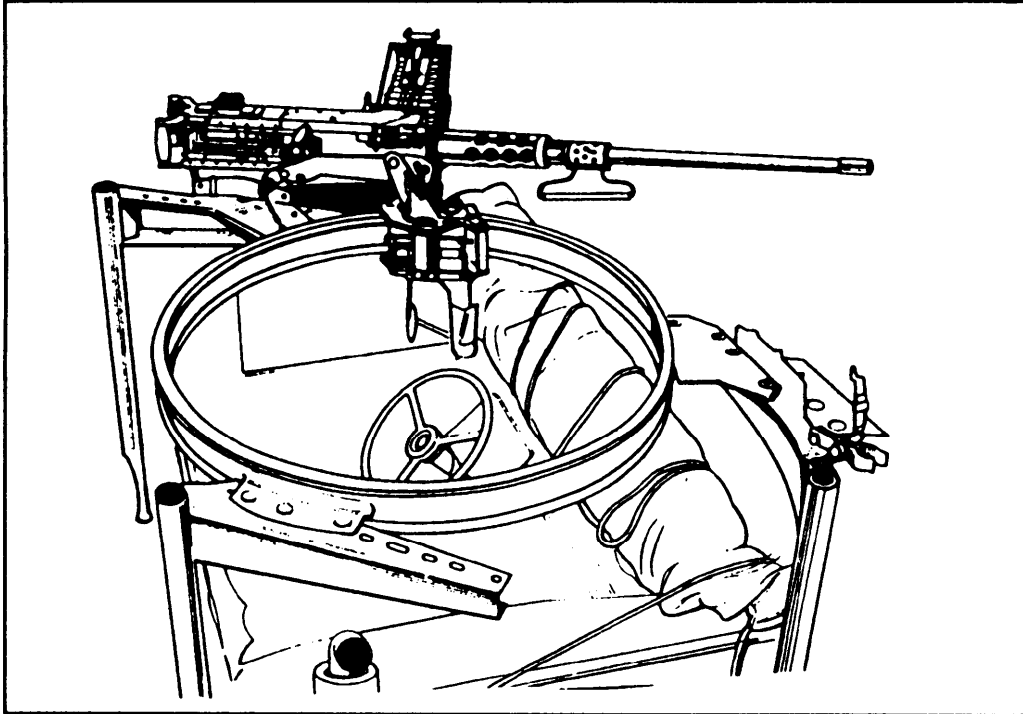

Figure 1-10. Truck mount, M36.

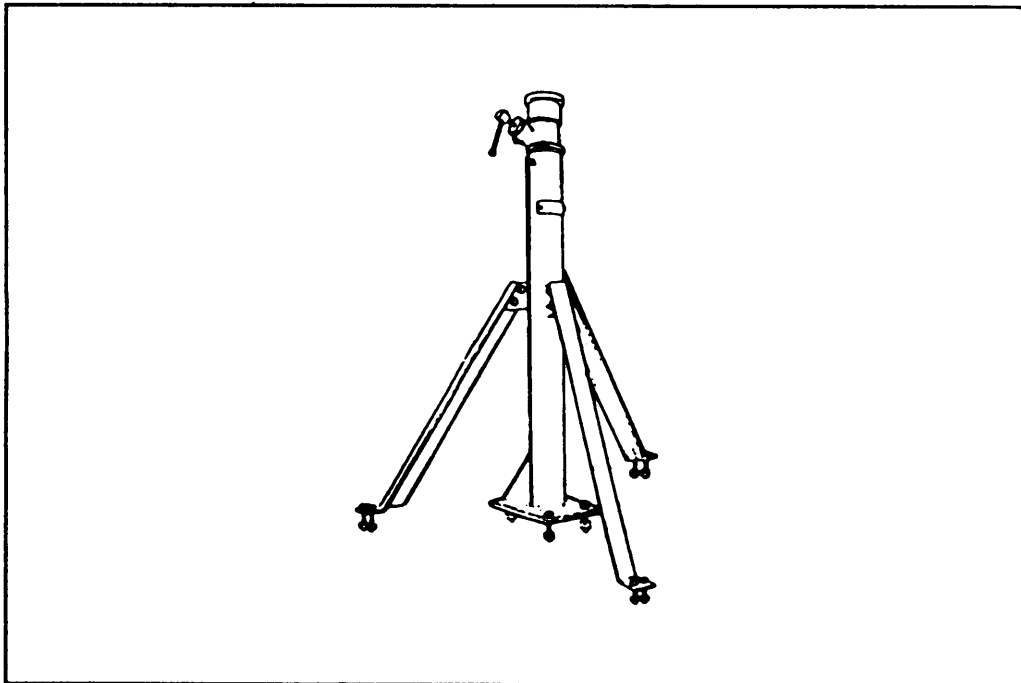

Figure 1-11. Pedestal truck mount, M31 C.

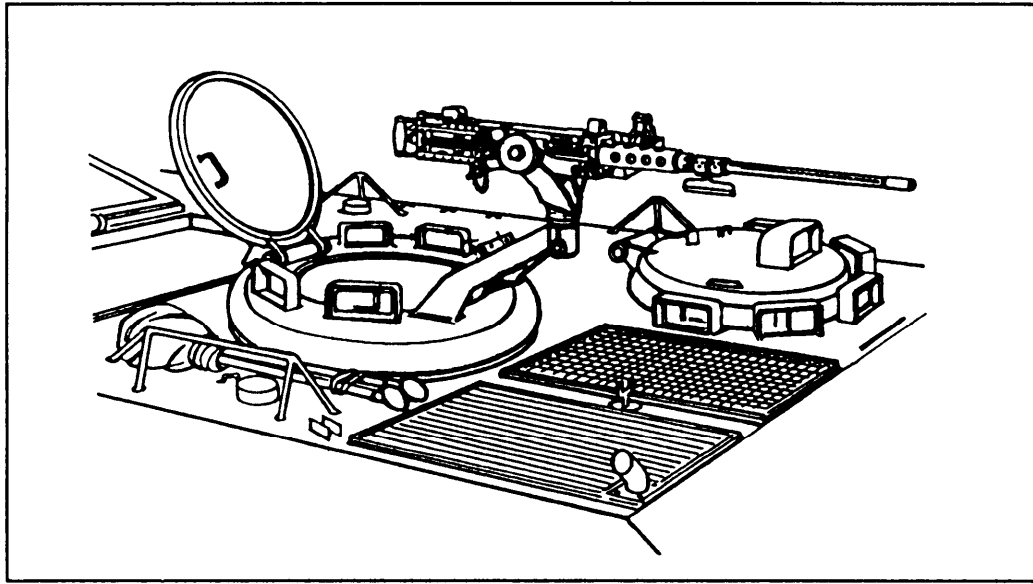

Figure 1-12. Cupola mount.

d. **MK64 Gun Cradle Mount.** This vehicle mount was primarily designed for the M2. However, because of its versatility, the MK64 will accept the MK 19 also (using the M2 mounting adapter assembly). The MK64 can be mounted on the following vehicles – M151 series, M966 HMMWV armament carrier, and the M113 series (Figure 1-13).

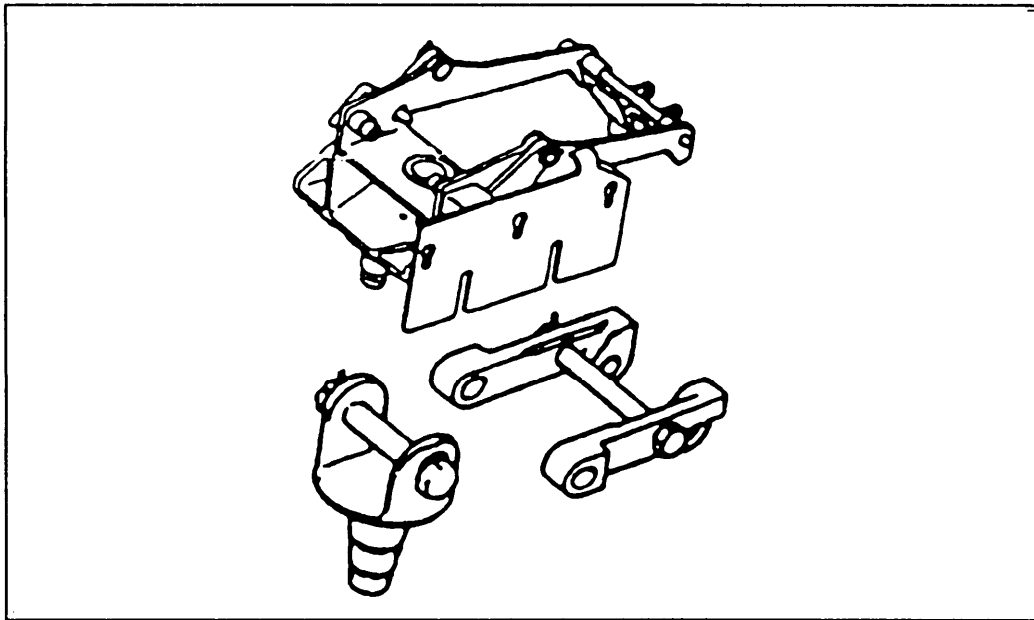

Figure 1-13. MK64 gun cradle.

1-7. AMMUNITION

This paragraph describes the ammunition used in caliber .50 machine guns (Figure 1-14). Soldiers should be able to recognize the types of ammunition available and know how to care for it. The caliber .50 cartridge consists of a cartridge case, primer, propelling charge, and the bullet. See TM 9-1300-200. The term bullet refers only to the small-arms projectile. There are eight types of ammunition issued for use in the caliber .50 machine gun. The tips of the various rounds are color-coded to indicate their type. The ammunition is linked with the M2 or M9 metallic links for use in the machine gun (Figure 1-15, page 1-18).

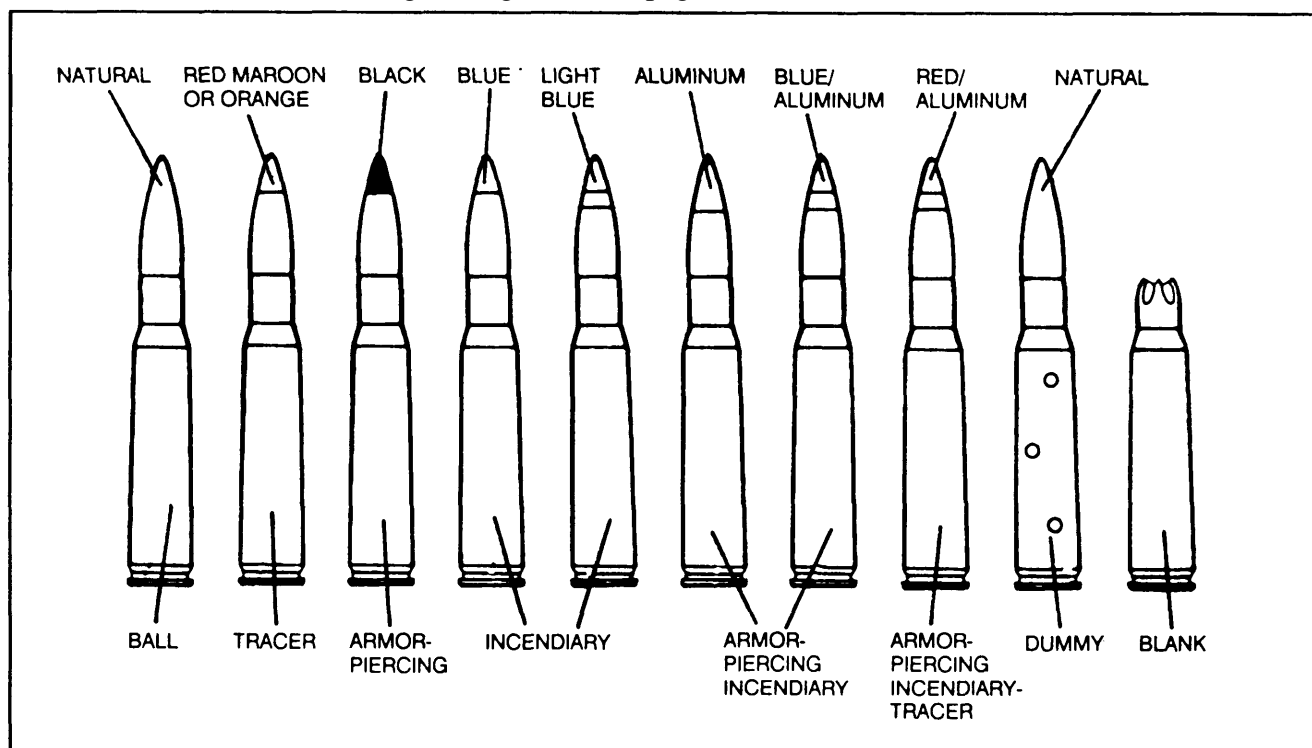

Figure 1-14. Ammunition for the M2.

a. **Classification.** The eight types of ammunition are used for the following purposes.

(1) *Ball.* For use in marksmanship training, and against personnel and light material targets.

(2) *Tracer.* To aid in observing fire. Secondary purposes are for incendiary effect and for signaling.

(3) *Armor-piercing.* For use against armored aircraft and lightly armored vehicles, concrete shelters, and other bullet-resisting targets.

(4) *Incendiary.* For incendiary effect, especially against aircraft.

(5) *Armor-piercing-incendiary*. For combined armor-piercing and incendiary effect.

(6) *Armor-piercing-incendiary-tracer*. For combined armor-piercing and incendiary effect, with the additional tracer feature.

(7) *Blank*. For simulated fire (contains no bullet).

(8) *High-pressure test*. For use only in proof firing of weapons and barrels.

(9) *Dummy*. For training (completely inert).

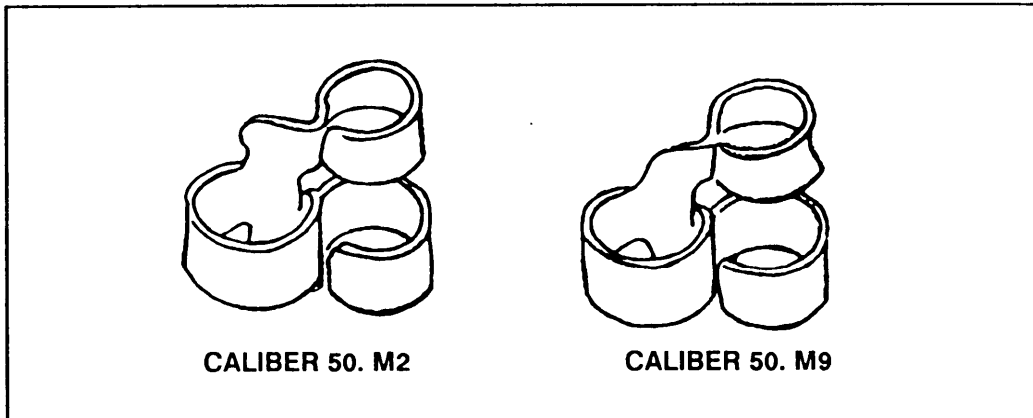

Figure 1-15. M2 and M9 links (closed loop).

b. **Ballistic Data.** The approximate maximum range and average muzzle velocity of some of the different types of caliber .50 ammunition authorized for use in the machine gun are noted in Table 1-4.

CARTRIDGE	MAXIMUM RANGE (meters)	METER TRACE	AVERAGE MUZZLE VELOCITY (feet per second)
Ball, M2	7,400	————	2,930
Tracer, M1 (with gilding metal jacket)	5,575	1,800	2,860
Tracer, M1 (with clad steel jacket)	5,450	1,800	3,030
Tracer, M17	5,450	2,450	3,030
Incendiary, M1	6,050	————	3,090
Armor-piercing, M2	7,400	————	2,930
Armor-piercing-incendiary, M8	6,470	————	3,050
Armor-piercing-incendiary-tracer, M20	6,470	*300-1,750	3,050

* This tracer is dim at near ranges but increases to bright as it moves farther from the gun.

Table 1-4. Ballistic data.

c. **Care, Handling, and Preservation.** Exercise care to prevent ammunition boxes from becoming broken or damaged. If they do, repair them immediately. Transfer all original markings to the new parts of the box. Do not open ammunition boxes until the ammunition is to be used. Ammunition removed from the airtight container, particularly in damp climates, is likely to corrode. Protect the ammunition from mud, sand, and water. If the ammunition gets wet or dirty, wipe it off at once with a clean, dry cloth. Wipe off light corrosion as soon as it is discovered. Turn in heavily corroded cartridges. Do not expose ammunition to the direct rays of the sun. If the powder is hot, excessive pressure may be developed when the weapon is fired. Do not oil or grease ammunition. Dust and other abrasives that collect on greasy ammunition are injurious to the operating parts of the gun. Moreover, oiled cartridges produce excessive chamber pressure. Do not fire dented cartridges, cartridges with loose bullets, or otherwise defective rounds.

d. **Storage.** Small-arms ammunition is not an explosive hazard, but under poor storage conditions it may become a fire hazard. Store ammunition of all classes away from radiators, hot water pipes, and other sources of heat. Whenever possible, store ammunition under cover. If it is necessary to leave ammunition in the open, keep it at least 6 inches off the ground and covered with a double thickness of tarpaulin. Place the tarpaulin so that it gives maximum protection and allows free circulation of air. Dig suitable trenches to prevent water from flowing under the ammunition pile.

e. **Miscellaneous Data.** Table 1-5 lists the maximum penetration in inches for an armor-piercing cartridge fired from the 45-inch barrel (muzzle velocity, 2,935 feet per second), which in some cases may enhance the leader's selection of targets to engage.

MATERIAL	INCHES AT:		
	200 METERS	600 METERS	1,500 METERS
Armor plate (homogeneous)	1.0	0.7	0.3
Armor plate (face-hardened)	0.9	0.5	0.2
Sand (100 pounds dry weight/cubic feet)	14.0	12.0	16.0
Clay (100 pounds dry weight/cubic feet)	28.0	27.0	21.0

Table 1-5. Maximum penetration for armor-piercing cartridge.

Table 1-6 lists the maximum penetration in inches for a ball cartridge fired from the 45-inch barrel (muzzle velocity, 2,935 feet per second):

MATERIAL	INCHES AT:		
	200 METERS	600 METERS	1,500 METERS
Sand (100 pounds dry weight/cubic feet)	14.0	12.0	6.0
Clay (100 pounds dry weight/cubic feet)	28.0	27.0	21.0
Concrete	2.0	1.0	1.0

Table 1-6. Maximum penetration for ball cartridge.

f. **Precautions.** Observe the general precautions concerning the firing and handling of ammunition in the field, as prescribed in TM 9-1300-206. Precautions that apply particularly to small-arms ammunition are:

(1) Do not fire small-arms ammunition (other than blank ammunition) until it has been positively identified by ammunition lot number and grade. Do not fire small-arms ammunition graded and marked "For Training Use Only" over the heads of troops.

(2) Do not use armor-piercing cartridges in demonstrations where tanks are used as demonstration targets.

(3) Before firing, make sure that the bore of the weapon is free from foreign matter, such as cleaning patches, mud, sand, and snow.

CHAPTER 2

MAINTENANCE

This chapter addresses the proper care of the machine gun to ensure its overall effectiveness and efficient functioning. The information includes the gunner's knowledge in disassembly and assembly, inspection, and maintenance procedures of the gun, its mount, the T&E, and its ammunition.

2-1. SAFETY

The paramount consideration while training with the machine gun is safety. It is imperative that the weapon be cleared properly before disassembly and inspection. (See Figure 2-1 for step-by-step procedures.)

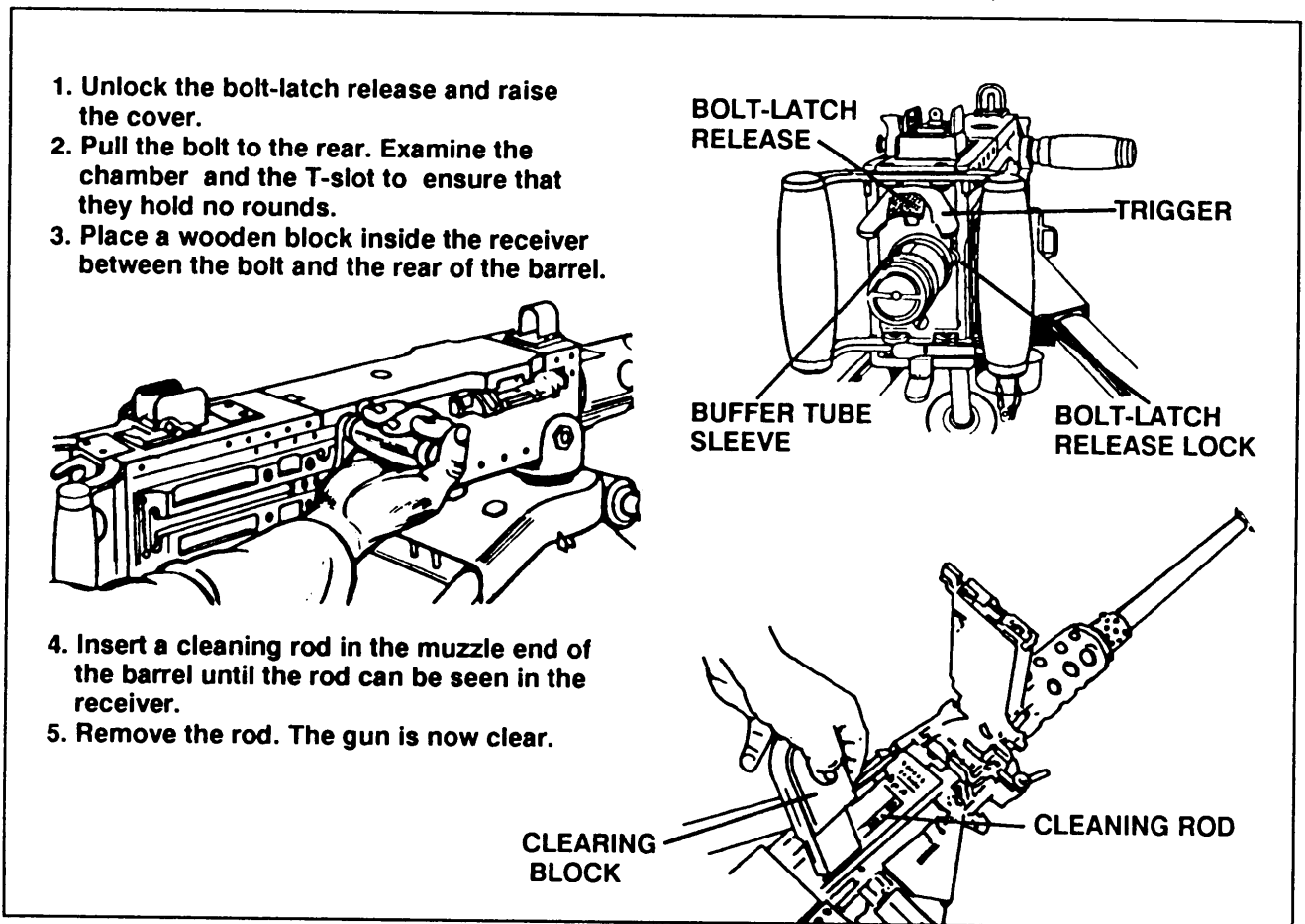

Figure 2-1. Clearing the weapon.

2-2. GENERAL DISASSEMBLY

The crew operating the MG must be fully familiar with its general disassembly, which consists of removing the major groups and assemblies for inspection and cleaning. The eight major groups that must be disassembled in the following order are barrel group, backplate group, driving spring rod assembly, bolt group, barrel extension group, barrel buffer body group, barrel buffer assembly, and receiver group (Figure 2-2).

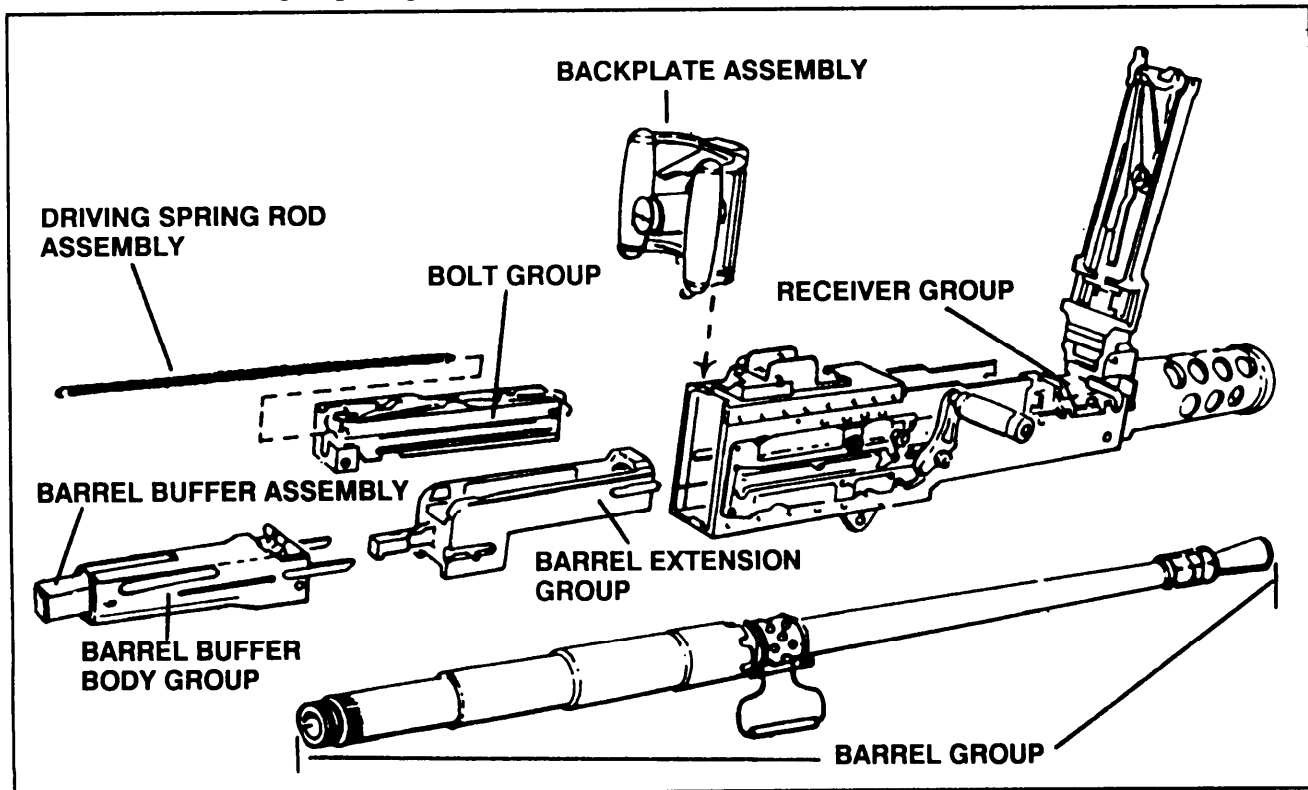

Figure 2-2. Major groups.

a. **Barrel Group.** Turn the cover latch and raise the cover group (Figure 2-3). Grasp the retracting slide handle with the right hand, palm up, and pull the recoiling parts to the rear until the lug on the barrel locking spring aligns with the 3/8-inch hole in the right sideplate of the receiver (just below the feedway exit). The barrel can be turned only when the lug is aligned with the 3/8-inch hole. Place the smallest loop of a caliber .50 link, or suitable spacer, between the trunnion block and the barrel extension (Figure 2-4). This holds the barrel locking spring lug aligned with the 3/8-inch hole in the right sideplate. Unscrew the barrel from the receiver (Figure 2-5, page 2-4). Be careful not to damage the

threads or barrel locking notches when setting the barrel down. Pull back slightly on the retracting slide handle and remove the link or spacer from the receiver.

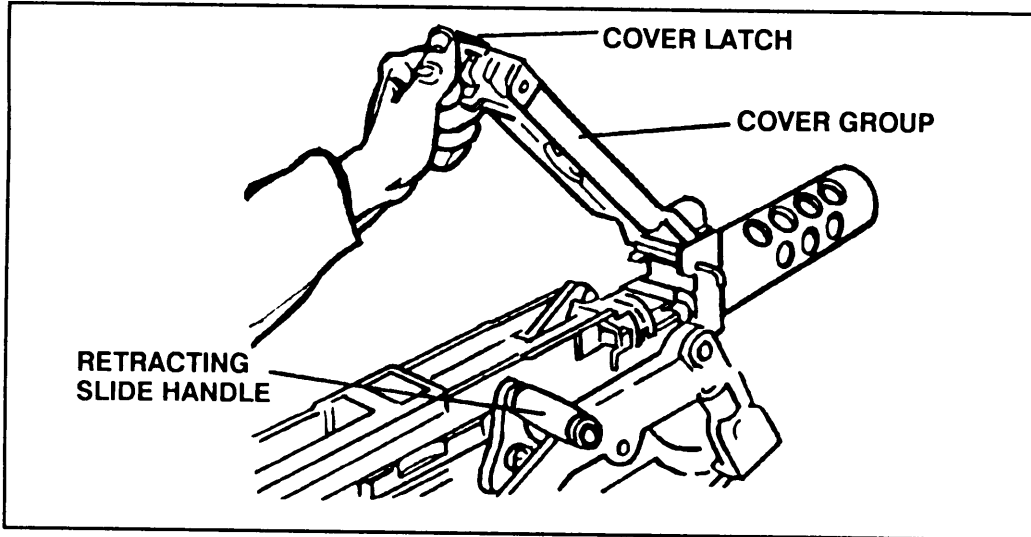

Figure 2-3. Raising the cover.

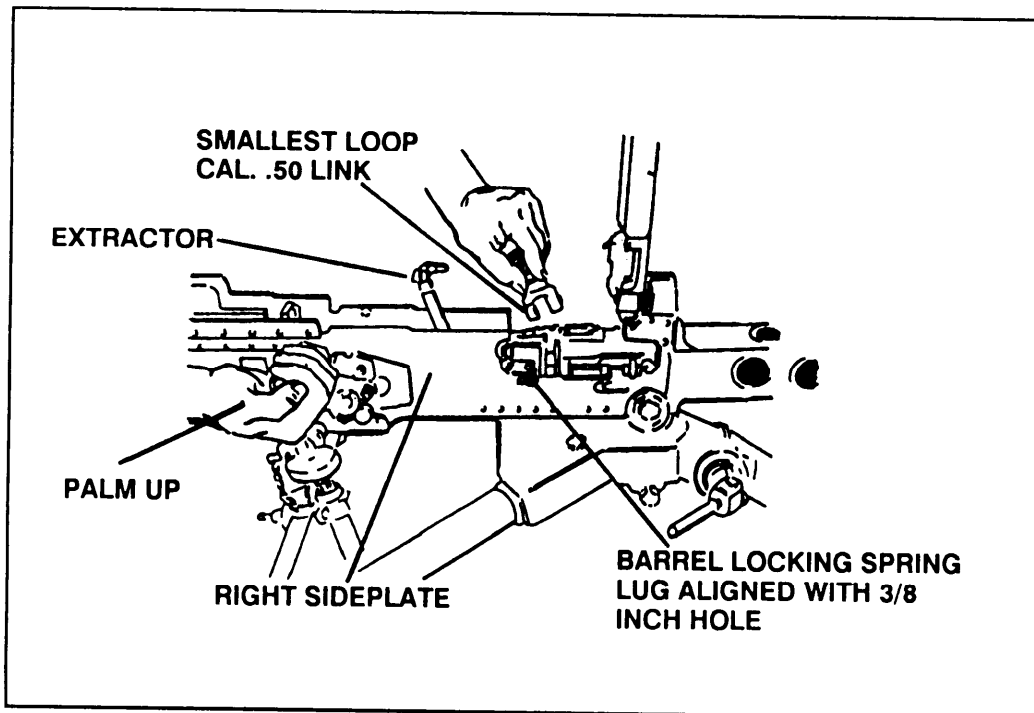

Figure 2-4. Aligning the lug on the barrel locking spring with the 3/8-inch hole in the right sideplate.

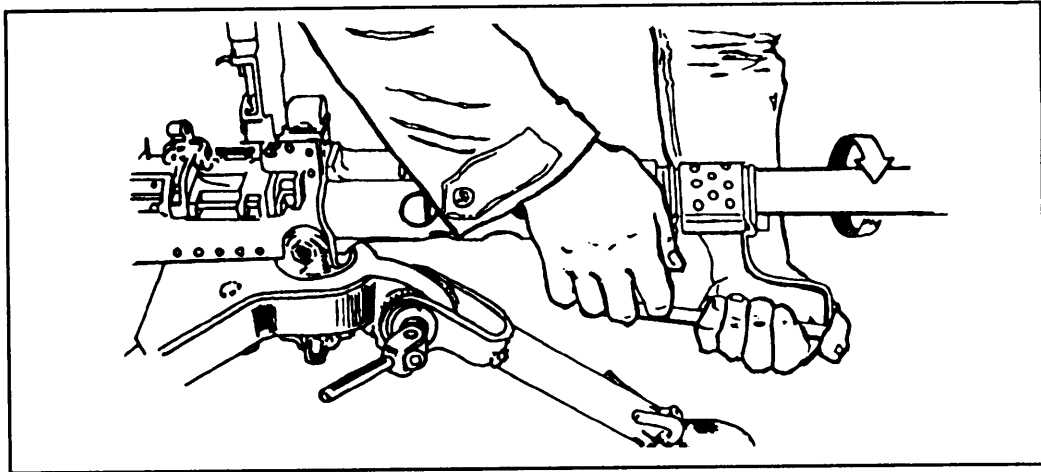

Figure 2-5. Removing the barrel.

b. **Backplate Group.** Ensure that the bolt latch release is up, free of the bolt latch release lock. If it is not, push down on the bolt latch release and turn the buffer tube sleeve to the right to free it (Figure 2-6). The bolt must be forward before the backplate is removed. If the bolt is to the rear, push down on the bolt latch release, place palm up on the retracting slide handle, and ease the bolt forward. The backplate latch lock and latch are below the buffer tube. Pull out on the lock and up on the latch; remove the backplate by lifting it straight up (Figure 2-7).

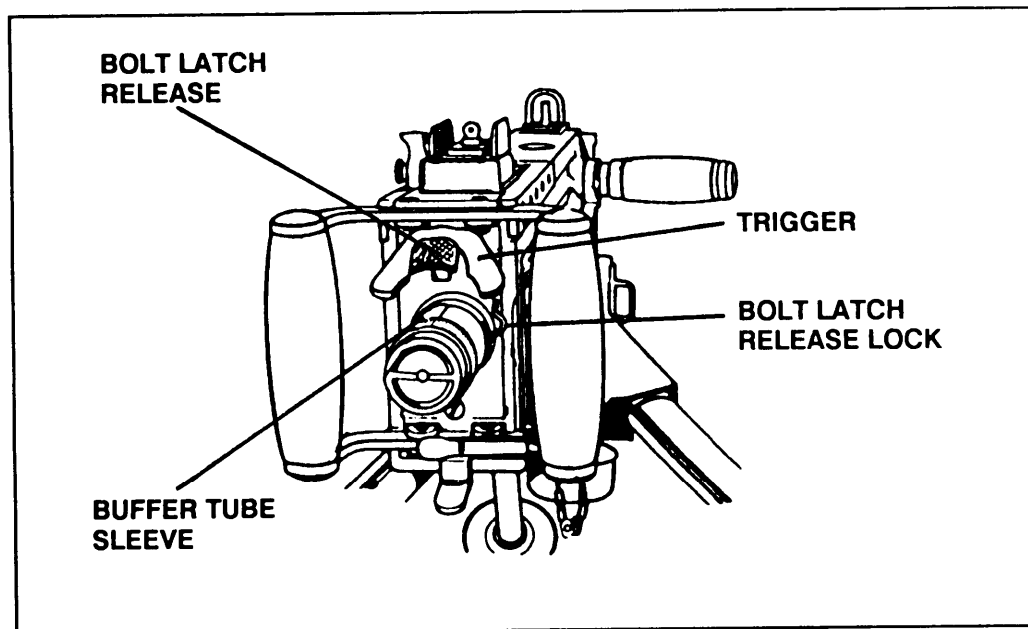

Figure 2-6. Releasing the bolt latch.

CAUTION

Care must be taken to prevent the bolt from slamming forward with the barrel removed.

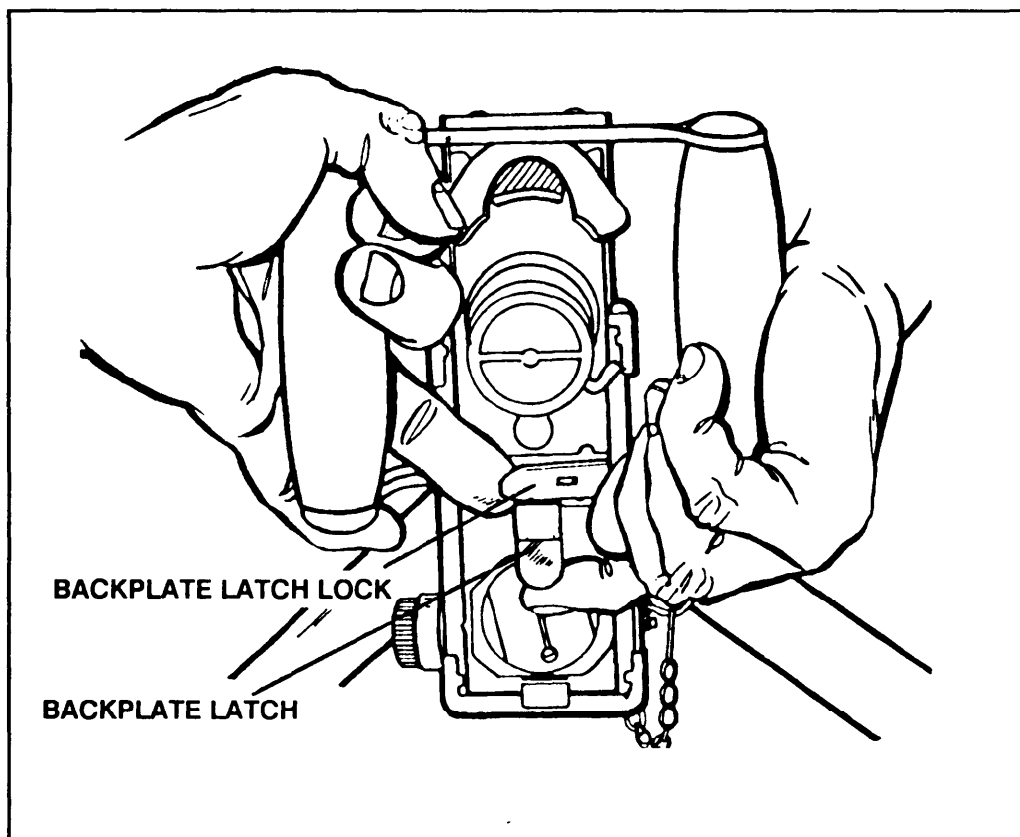

Figure 2-7. Removing the backplate.

c. **Driving Spring Rod Assembly.** The inner and outer driving springs and driving spring rod are located inside the receiver next to the right sideplate (Figure 2-8, page 2-6). Push in on the head of the driving spring rod and push to the left to remove the driving spring rod retaining pin from its seat in the right sideplate. Pull the driving spring assembly to the rear and out of the receiver.

WARNING

Never attempt to cock the gun while the backplate is off and the driving spring assembly is in place. If the backplate is off and the driving spring assembly is compressed, the retaining pin on the driving spring rod can slip from its seat in the sideplate and could cause serious injury to anyone behind the gun.

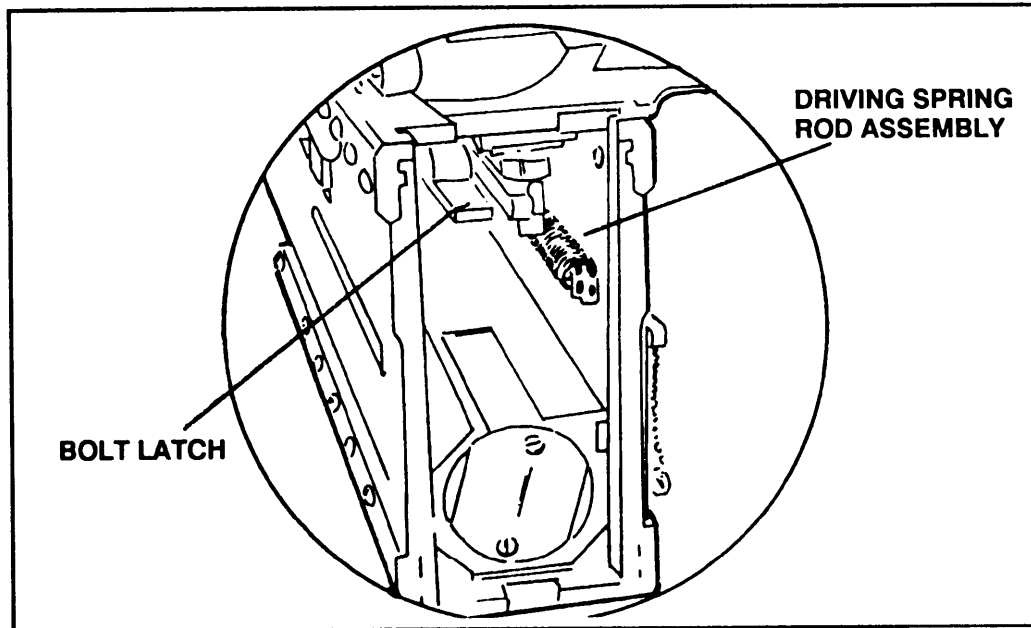

Figure 2-8. Removing the driving spring rod assembly.

d. **Bolt Stud.** Grasp the retracting slide handle and give it a quick jerk, freeing the bolt from the barrel extension. Align the collar of the bolt stud with the clearance hole in the bolt slot on the right sideplate, and remove the bolt stud (Figure 2-9). If the bolt is accidentally moved all the way to the rear, the bolt latch will engage in the bolt latch notches in the top of the bolt. If this occurs, raise the bolt latch (left of the trigger lever) and push the bolt forward to align the bolt stud with the clearance hole (Figure 2-10).

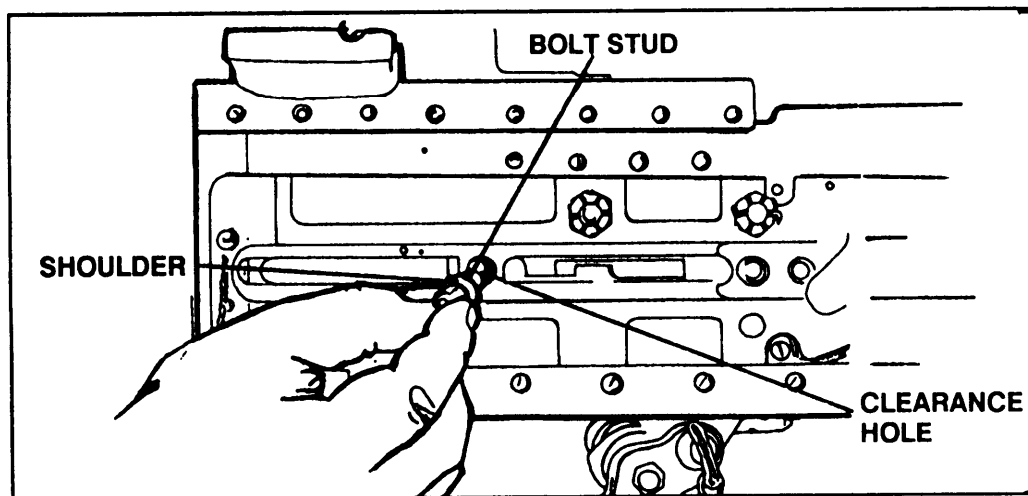

Figure 2-9. Removing the bolt stud.

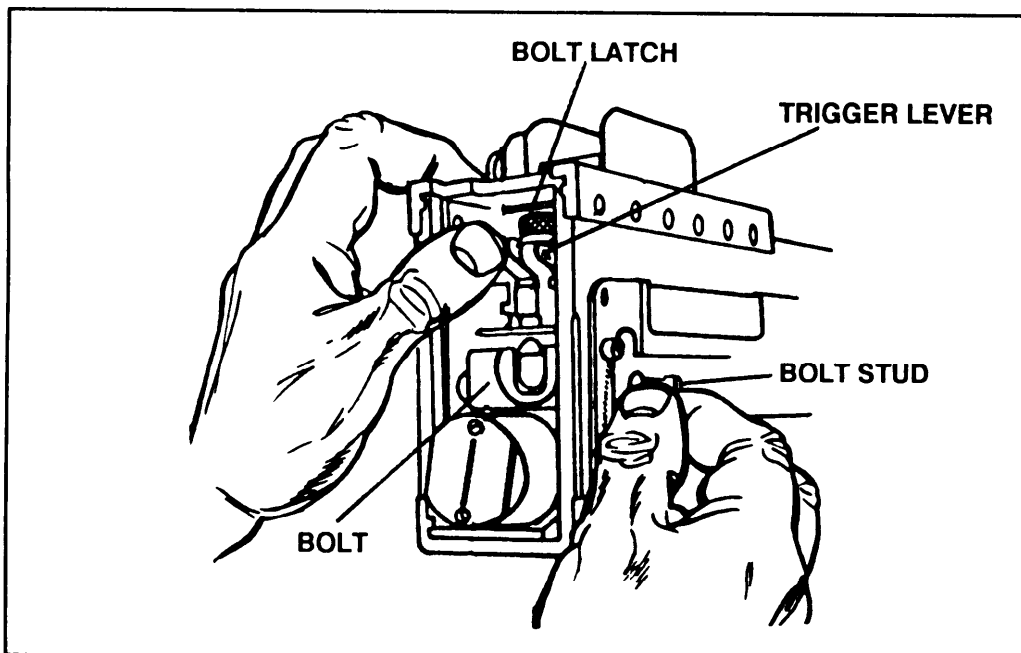

Figure 2-10. Freeing the bolt.

e. **Bolt Group.** After freeing the bolt, slide it to the rear and out of receiver (Figure 2-11). Place the bolt down on its right side (with the extractor arm up), so that the extractor will not fall from the bolt.

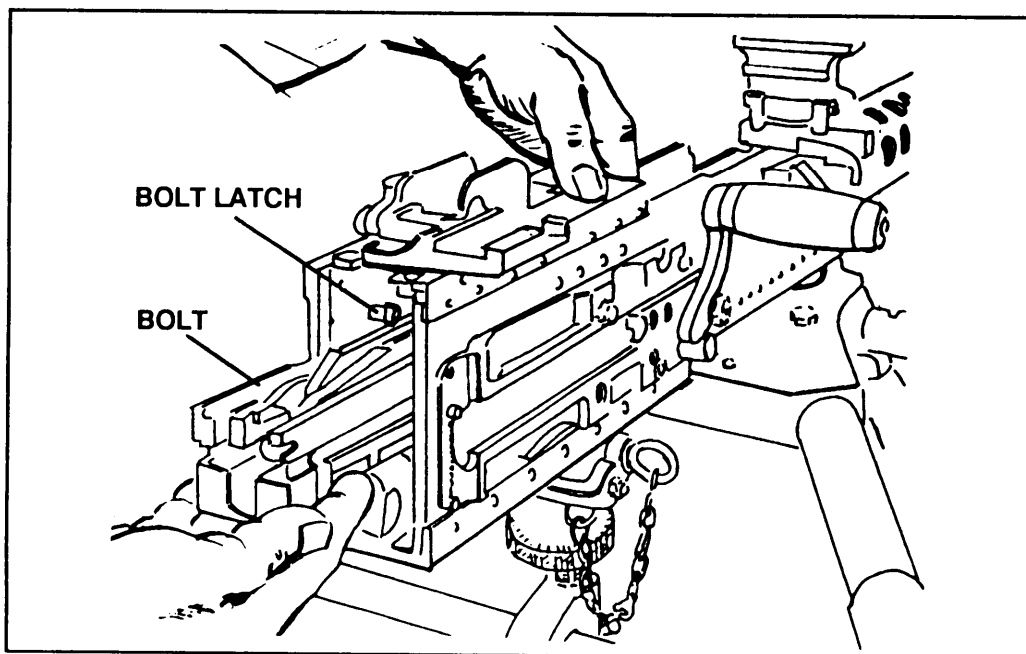

Figure 2-11. Removing the bolt from the receiver.

f. **Barrel Buffer Body Group and Barrel Extension Group.** Insert the drift of a combination tool, or other pointed instrument, through the hole in the lower rear corner of the right sideplate. Push in on the barrel buffer body lock. At the same time, place one hand in the receiver and push the barrel extension group and barrel buffer group to the rear (Figure 2-12). Remove the barrel buffer group and barrel extension group from the receiver. Separate the two groups by pushing forward on the tips of the accelerator (Figure 2-13).

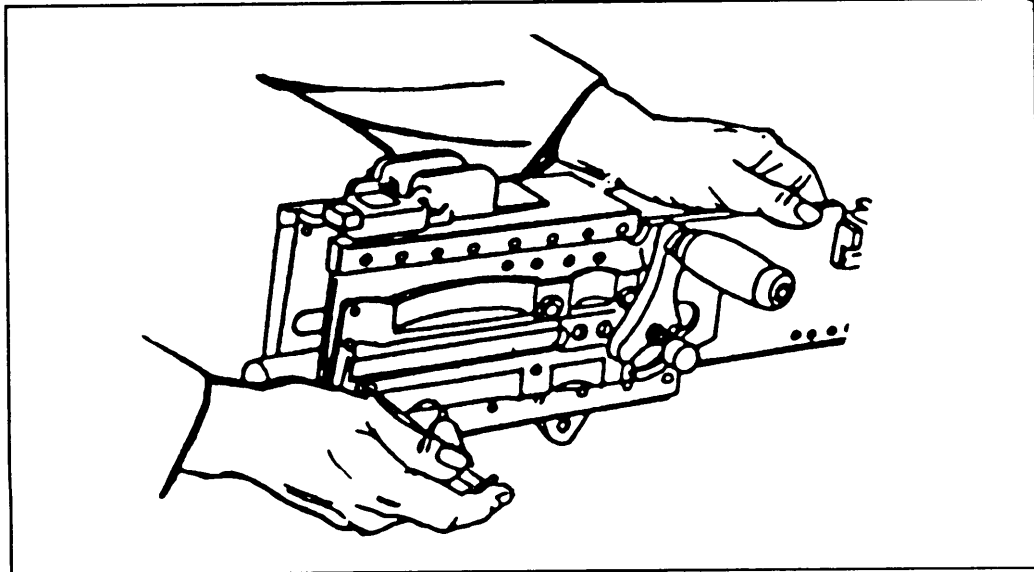

Figure 2-12. Removing barrel buffer group and barrel extension group.

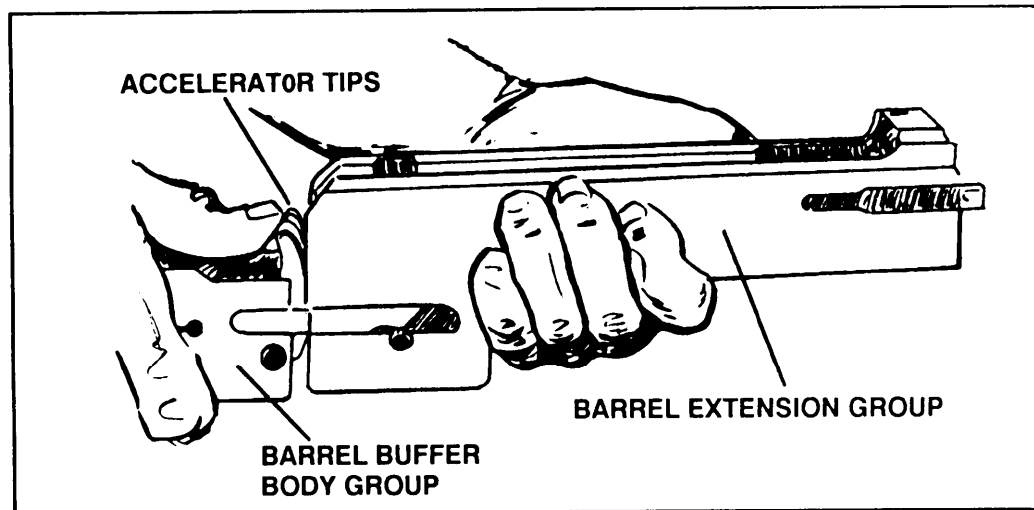

Figure 2-13. Separating the groups.

g. **Barrel Buffer Assembly.** Pull the barrel buffer assembly from the rear of the barrel buffer body group. The barrel buffer assembly will not be disassembled (Figure 2-14). This completes general disassembly.

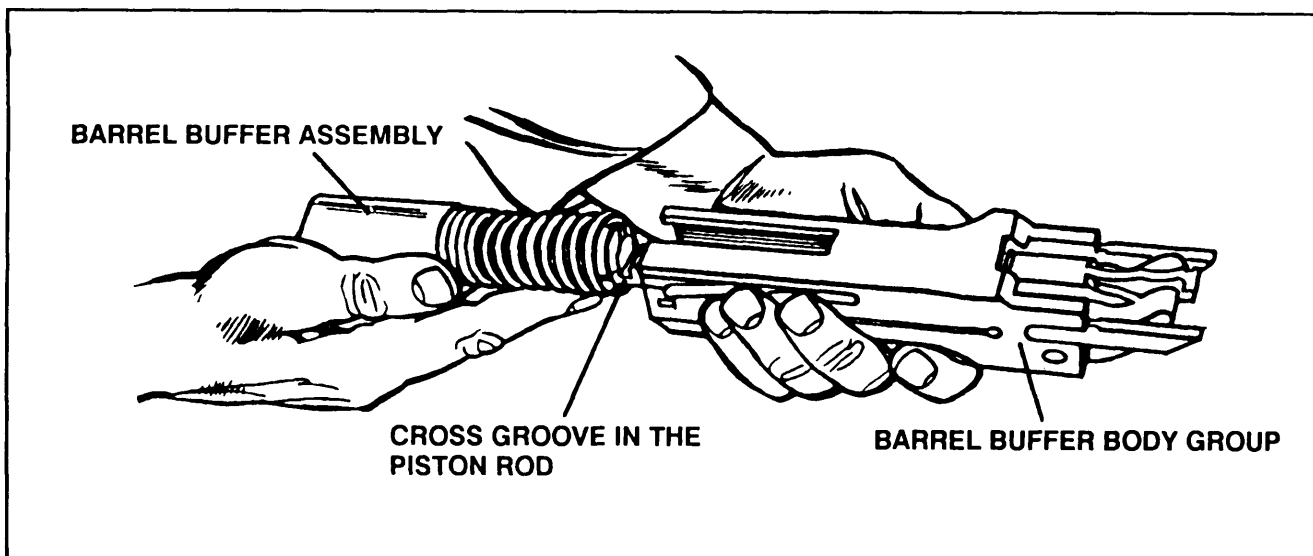

Figure 2-14. Separating the barrel buffer assembly from the barrel buffer body group.

2-3. CLEANING, INSPECTION, AND LUBRICATION

To ensure proper care of the MG, it is necessary to have a system of maintenance or an SOP for the frequency of cleaning. Each gun should be cleaned as soon after firing as possible and each time it is exposed to field conditions. Under combat conditions, the gun should be cleaned and oiled daily. Under extreme climatic and combat conditions, it may be necessary to clean and lubricate more frequently. Under ideal conditions, where the gun is not used, and is stored in a clean, dry place, it may only be necessary to inspect, clean, and lubricate every 5 days. The gun should be disassembled, cleaned, and oiled in a clean, dry location. If possible, keep the gun covered with a gun cover, canvas, tarpaulin, or poncho when not in use.

a. **Routine Care and Cleaning.** Before firing (when the situation permits), take the following steps to ensure efficient functioning of the machine gun:

- Disassemble the gun into its major groups or assemblies.
- Clean the bore and chamber, and lightly oil them.
- Clean all metal parts thoroughly with CLP. See paragraph 2-3f for lubrication procedures.

b. **Care and Cleaning Under Unusual Conditions.** Extreme cold, hot, dry, and tropical climates affect the gun and its functioning. Care should be taken under these climatic conditions to ensure that the gun is cleaned daily with the prescribed lubricants and protected from the elements by some sort of cover if possible. Further information on care and cleaning of the gun under unusual climatic conditions can be found in TM 9-1005-213-10.

c. **Care and Cleaning of M3 Mount and Accessories.** The mount and accessories, such as the ammunition chest and spare parts, should also be kept clean and lubricated. Painted surfaces should be spot painted when necessary. Moving surfaces should be inspected and oiled with the prescribed lubricant. All external surfaces of the mount should be kept clean and lightly oiled. Be particularly careful that the pintle bushing is clean and lightly oiled, and that the pintle lock release cam is well-lubricated and free from grit. The sleeve lock indexing levers and telescopic legs should be clean and lubricated enough for ease in use. The mount should be cleaned and oiled with the same regularity and in the same manner as the gun.

d. **Maintenance and Inspection.** Units must establish guidelines and conduct regular maintenance and inspection to keep the machine gun and its mounts in operational conditions.

(1) *Gun maintenance.* The importance of a thorough knowledge of care, cleaning, and maintenance of the machine gun cannot be overemphasized because these actions determine whether or not the gun will function properly when needed. The bore and chamber must be properly maintained to preserve accuracy. Because of the close fit of working surfaces and the high speed at which the gun operates, the receiver and moving parts must be kept clean, correctly lubricated, and free from burrs, rust, dirt, or grease to ensure proper, efficient functioning.

(2) *Mount maintenance.* The care, cleaning, lubrication, and adjustment of the mounts used with the gun are no less important. The functioning of the gun and mount together determine overall effectiveness. All accessories and equipment used with the gun and mount, including ammunition, must also be properly maintained.

(3) *Inspection.* When inspected, the machine gun should be completely disassembled. Inspecting personnel should look for dirt, cracks, burrs, and rust.

e. **Inspection Checklist.** Table 2-1 is an inspection checklist to be used as a guide for crewmembers or inspecting personnel to ensure that the gun and equipment are properly maintained.

UNIT	INSPECTION
1. GUN.	
a. Barrel.	Inspect the bore and chamber for rust. See that they are clean and lightly oiled.
b. Moving parts.	See that they are clean and lightly oiled. Operate the retracting slide handle and bolt latch release several times to see that the parts function without excessive friction.
c. Headspace and timing.	Check with the gauges to ensure that headspace and timing are correct.
d. Rear sight and windage knob.	Ensure that the sight is in good condition, clean, free of grease or dirt, and lightly oiled. Elevation should be set at 1,000, windage zero, and the sight should be down.
2. MOUNT (M3, MK64, M36, or M4).	See that it is clean, lightly lubricated, and that all clamps are securely tightened. It should function properly and be complete.
3. SPARE PARTS AND TOOLS.	Inspect to see that they are clean and lightly oiled. See that spare parts kits are complete and in good condition. Replacement parts should be requisitioned and newly drawn parts examined.
4. T&E.	See that it is clean, lightly lubricated, and that both hand wheels work properly.
5. AMMUNITION.	See that ammunition is properly stored, and that boxes and ammunition are in good condition and not oiled.

Table 2-1. Inspection checklist.

f. **Lubrications.** Use cleaner, lubricant, preservative to clean the machine gun. As its name implies, it cleans, lubricates, and preserves all in one application.

(1) After cleaning the gun with CLP, wipe it dry and reapply a thin coating. Allow this thin coat to dry on the parts for a short time before reassembly. CLP deposits a thin coating on the metal which minimizes carbon buildup and prevents foreign material from sticking. It is this coating that provides the frictionless operation of the weapon parts, not liquid oil deposited on them. A gun treated with CLP will operate better and remain clean longer than one treated with any other cleaning material. Use of CLP will reduce maintenance costs and extend the life of the weapon.

(2) Rifle bore cleaner is a cleaning solvent which can be used to clean powder residue, carbon, and dirt from weapons. RBC does not preserve or lubricate a weapon. If you clean a weapon with RBC, dry the weapon and lubricate it with lubricating oil, semifluid (LSA); lubricating oil, special purpose (PL-S); or lubricating oil, general purpose (PL-M). The use of these oils will cause sand or grit to stick to the weapon. RBC and oil should be used only when CLP is not available.

2-4. MAINTENANCE PROCEDURES

There are certain actions that must be taken before, during, and after firing to properly maintain the gun. See Table 2-2 for a preoperation checklist.

PART	BEFORE	DURING FIRING OR TEMPORARY CESSATION	AFTER
Bore	Make sure it is clear and clean.		Clean and oil lightly.
Moving parts	Oil lightly and test for worn or broken parts. They should function without excessive friction.	Lubricate working parts. Observe the functioning of the gun to anticipate failures.	Inspect, clean, and oil lightly.
Headspace and timing	Check adjustment by gauge and correct if necessary.	Watch for bulged cases to prevent a ruptured (separated) case. If a separated case occurs, remove it and readjust headspace.	Check adjustment.
Rear sight and windage knob	See that the sight is clean and functions properly. Set sight at 1,000, windage zero.	Keep properly set.	Clean and oil; set at 1,000, windage zero.
Spare parts and tools	Clean and oil spare parts and tools. Check kits for completeness. Examine newly drawn parts.	Keep available.	Clean and oil. Check and replace damaged or missing parts.
Ammunition	Have an adequate supply; clean, correctly loaded, and in good condition. DO NOT OIL.	Keep correctly aligned with the feedway; check resupply. Protect from sun, moisture, and dirt. Watch for link stoppage.	Clean, store carefully, and replenish supply.

Table 2-2. Operational checklist.

2-5. MAINTENANCE UNDER NBC CONDITIONS

If contamination is anticipated, apply oil to all outer metal surfaces of the weapon. **DO NOT OIL AMMUNITION.** Keep the weapon covered as much as possible. If the weapon is contaminated, decontaminate it as prescribed by FM 3-5 and then clean and lubricate it.

2-6. GENERAL ASSEMBLY

To assemble the gun, replace the groups and assemblies in reverse order of their removal in disassembly.

a. **Barrel Buffer Assembly and Barrel Buffer Body Group.** Replace the barrel buffer assembly in the barrel buffer body group, with the key on the spring guide to the right. This key must fit in its slot in the right side of the barrel buffer body. Turn the barrel buffer tube until the screwdriver slot (in the rear of the tube) is vertical and the arrow is pointing to the right. The stud on the tube lock will now engage the serrations in the barrel buffer tube to keep the tube from turning. Push the barrel buffer assembly fully forward (Figures 2- 15 and 2-16).

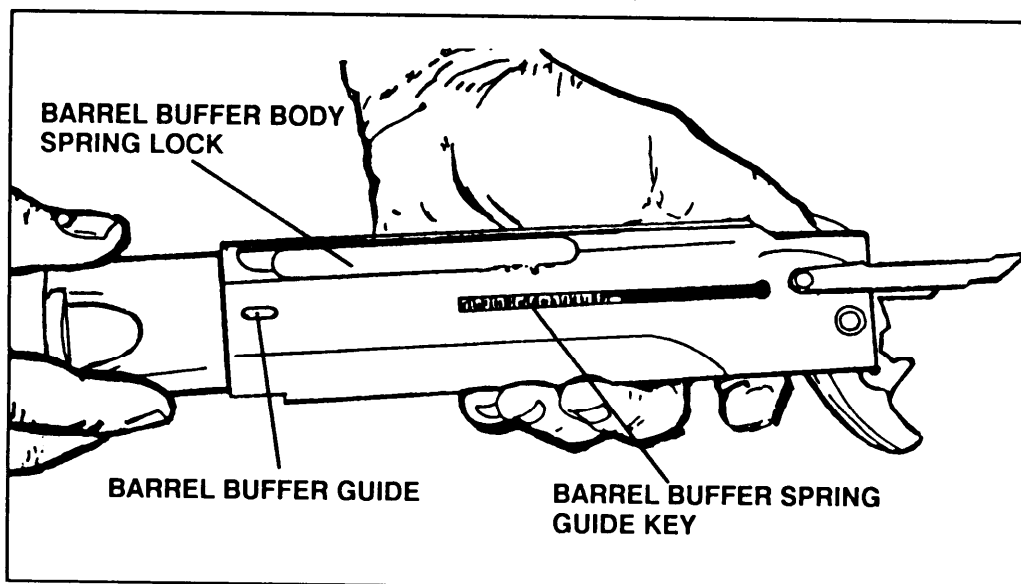

Figure 2-15. Replacing barrel buffer assembly.

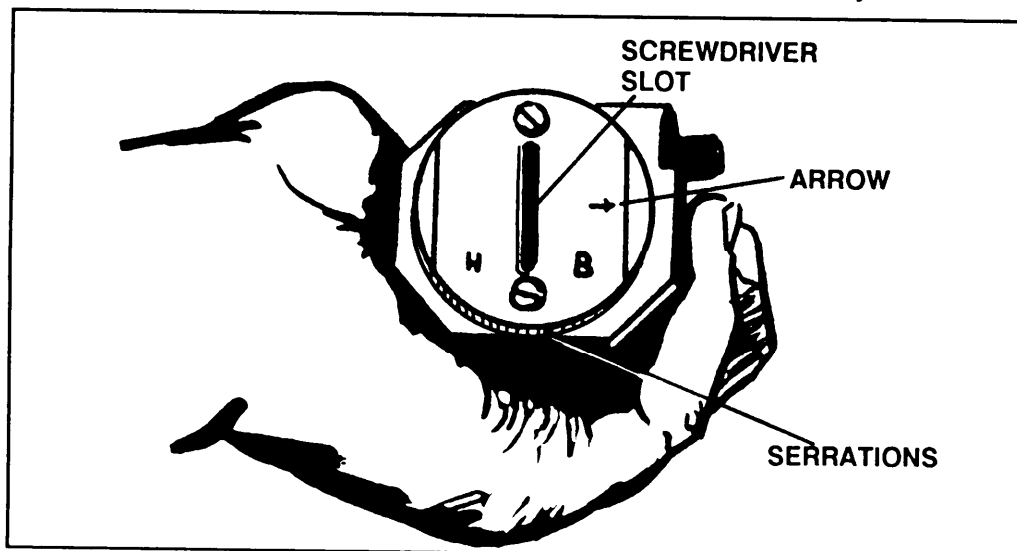

Figure 2-16. Replacing the barrel buffer tube.

b. **Barrel Buffer Group and Barrel Extension Group.** To join the two groups together, hold the barrel buffer group in the right hand, with the index finger supporting the accelerator. Join the notch on the shank of the barrel extension group with the cross-groove in the pistol rod of the barrel buffer assembly. At the same time, align the breech lock depressors with their guideways in the sides of the barrel extension, ensuring that the tips of the accelerator are against the rear end of the barrel extension (claws against the shank) (Figure 2-17). Push the groups together. As the accelerator rotates to the rear, press down on its tips to ensure positive locking of groups. Place the groups in the receiver, and push them forward until the barrel buffer body spring lock snaps into position. When the parts are properly locked in place, the barrel buffer tube should protrude about 1 1/8 inches from the rear of the barrel buffer body group.

c. **Bolt.** Place the bolt in the receiver, with the top of the cocking lever forward and the extractor down. The barrel extension, barrel buffer, and bolt groups may be assembled and returned to the receiver together (Figure 2-18).

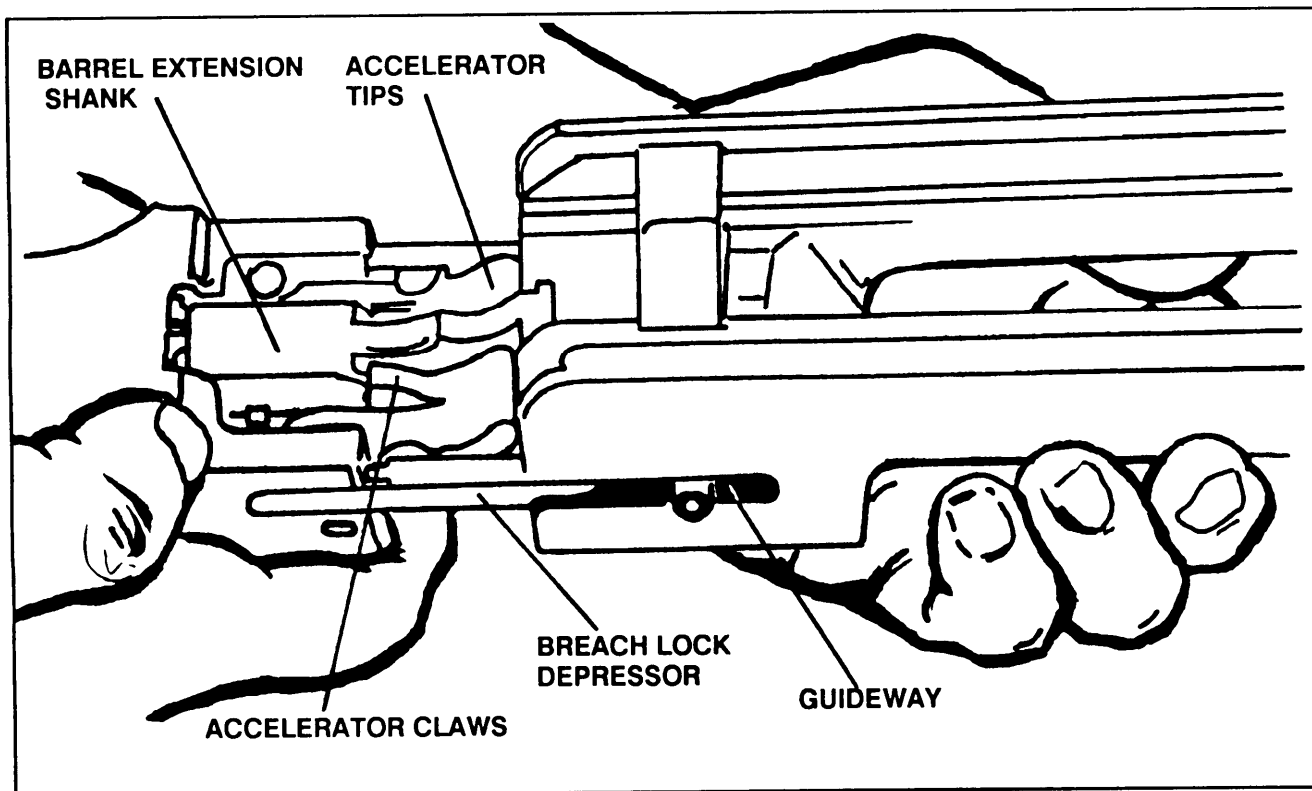

Figure 2-17. Joining the barrel extension group and barrel buffer group.

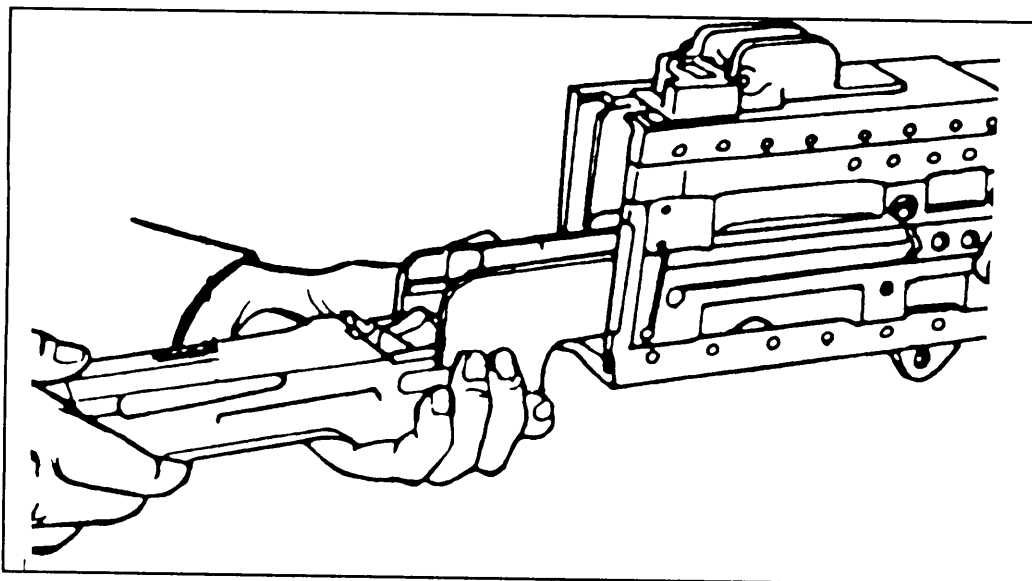

Figure 2-18. Returning the barrel extension, barrel buffer, and bolt groups together.

d. **Bolt Stud.** Align the stud hole in the bolt with the clearance hole and replace the bolt stud, ensuring that the collar of the stud is inside the sideplate (Figure 2-19).

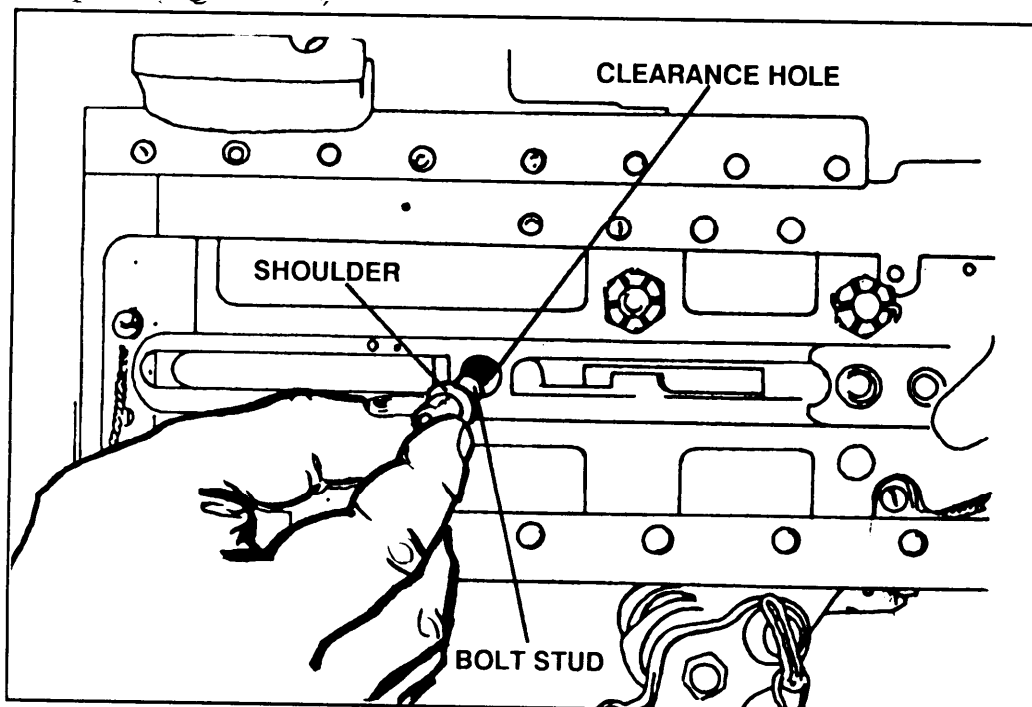

Figure 2-19. Replacing the bolt stud.

e. **Driving Spring Group.** Press up on the bolt latch and push the bolt all the way forward by pushing on the bolt stud only. Place the end of the driving spring rod in its hole in the rear of the bolt, and push forward on the driving spring group and the barrel buffer tube. Press in and to the right on the head of the driving spring rod and place the retaining pin in its seat in the right sideplate.

NOTE: At this time, the barrel buffer tube should be completely inside the receiver. If not, the barrel buffer body spring is not properly seated.

f. **Backplate Group.** Hold the backplate with the latch down and the trigger up; place the backplate guides in their guideways. Hold out on the latch lock and tap the backplate into position until the latch snaps into place (Figure 2-20). Release the latch lock and pull up on the backplate group to ensure it is firmly seated.

CAUTION

Do not use the driving rod to drive the bolt forward from the rear position. This may damage the driving spring group and cause a stoppage.

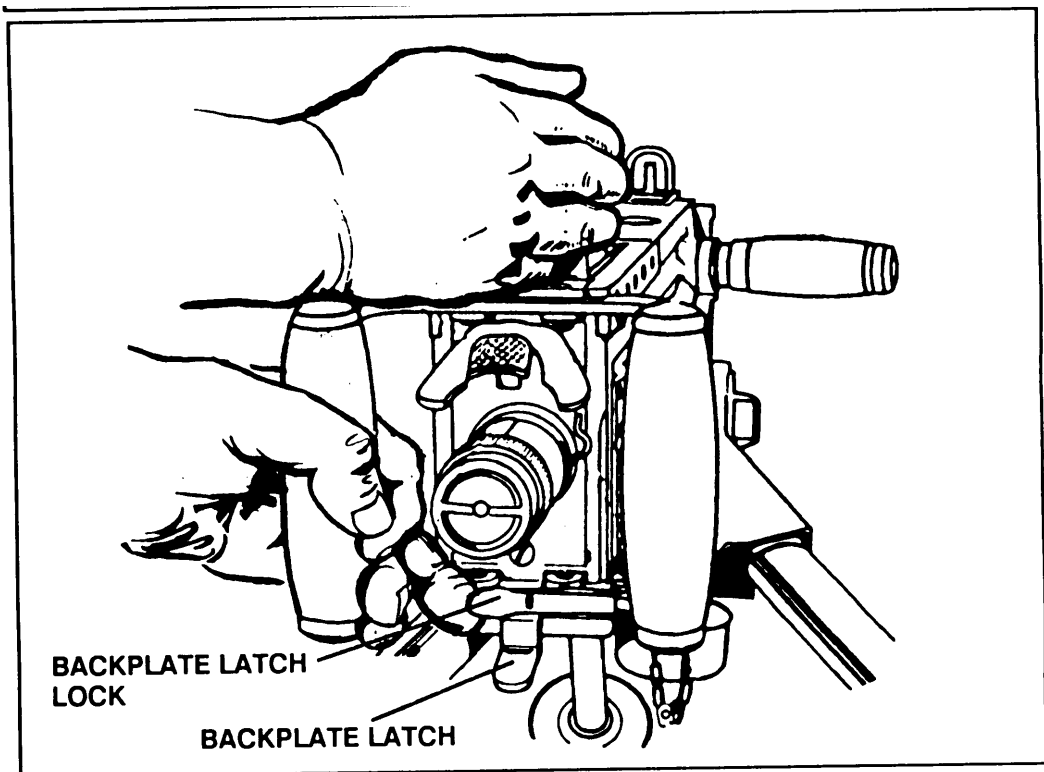

Figure 2-20. Replacing the backplate group.

g. **Barrel.** Pull the retracting slide handle to the rear until the lug on the barrel locking spring is visible through the 3/8-inch hole in the right sideplate. Place the smallest loop of a caliber .50 link, or suitable spacer, between the trunnion block and the barrel extension. Screw the barrel all the way into the barrel extension; then unscrew the barrel two notches. Remove the link and close the cover. This completes general assembly.

2-7. FUNCTION CHECK

A function check must be performed as soon as the weapon is assembled to ensure that the weapon has been assembled correctly. The following procedures should be taken to check the function of the weapon.

- Place the weapon in the single-shot mode.
- Open the cover and lock the bolt to the rear (bolt should stay to rear while in the single-shot mode).
- Hold the retractor handles, press the bolt latch release, and ride the bolt forward.
- Press down on the trigger; weapon should fire. (Check T-slot to ensure that firing pin does protrude.)
- Place the weapon in the automatic-fire mode.
- Pull the retractor slide handle to the rear and hold. (Bolt should not lock to rear.)
- Release the pressure on the slide handles and ride the bolt forward.
- Make sure firing pin does not protrude.
- Press trigger; weapon should fire.
- Make sure firing pin does protrude.

NOTE: If weapon is going to be fired after assembly, then the headspace and timing must be set. (See Chapter 3 for these procedures.)

CHAPTER 3

OPERATION AND FUNCTIONING

This chapter explains the operation of the MG. It discusses the loading, unloading, and clearing procedures, and the cycle of functioning of the weapon. When training the cycle of functioning using dummy ammunition, it is imperative that all safety procedures be followed.

3-1. OPERATION

The overall operation of the MG includes how to load, unload, and clear the weapon. During the weapon's operation, it is mandatory that all ammunition be free of dirt and corrosion, that the ammunition be properly linked, and that the double-linked end be at the top of the ammunition can.

3-2. LOADING PROCEDURES

Trainers must ensure that the weapon functions correctly and that proper headspace and timing have been set before loading. When loading in either mode, the ammunition is fed into the MG in the same manner (Figure 3-1). Ensure that the bolt is forward and the cover is closed. Insert the double-loop end of the ammunition belt into the feedway until the first round is engaged by the belt-holding pawl.

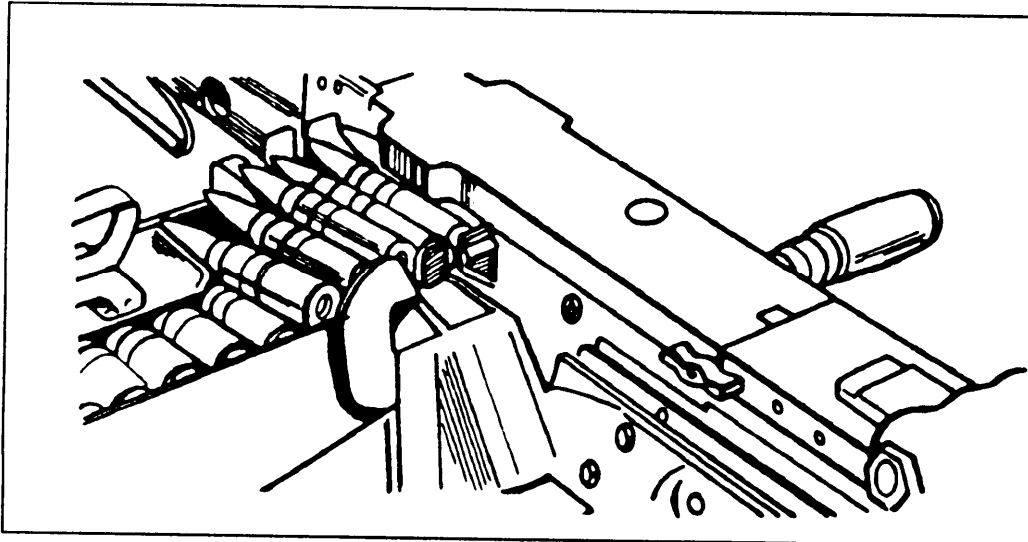

Figure 3-1. Inserting ammunition.

Figure 3-2 shows the correct procedures to use in the machine gun in the single-shot or automatic mode.

a. **Single-Shot Mode.** When engaging targets at ranges greater than 1,100 meters, using the single-shot mode (firing one round at a time) allows the gunner to deliver well-aimed fire on the target. To load in the single-shot mode –

(1) Keep the bolt-latch release unlocked in the up position and release it manually for each round.

(2) Jerk the retracting slide handle to the rear (Figure 3-3). Return the retracting slide handle to the forward position and then release the bolt by pressing the bolt latch release. The gun is now half-loaded.

(3) To complete loading, jerk the retracting slide handle to the rear a second time and lock it. Return the retracting slide handle to the forward position. Press the bolt latch release. When the bolt goes forward for the second time, the gun is loaded.

b. **Automatic Mode.** To load in the automatic mode –

(1) Lock the bolt-latch release down with the bolt-latch-release lock.

(2) Jerk the retracting slide handle to the rear and release it. The gun is now half-loaded.

(3) To complete loading, jerk the retracting slide handle to the rear a second time and release it. When the bolt goes forward for the second time, the gun is loaded.

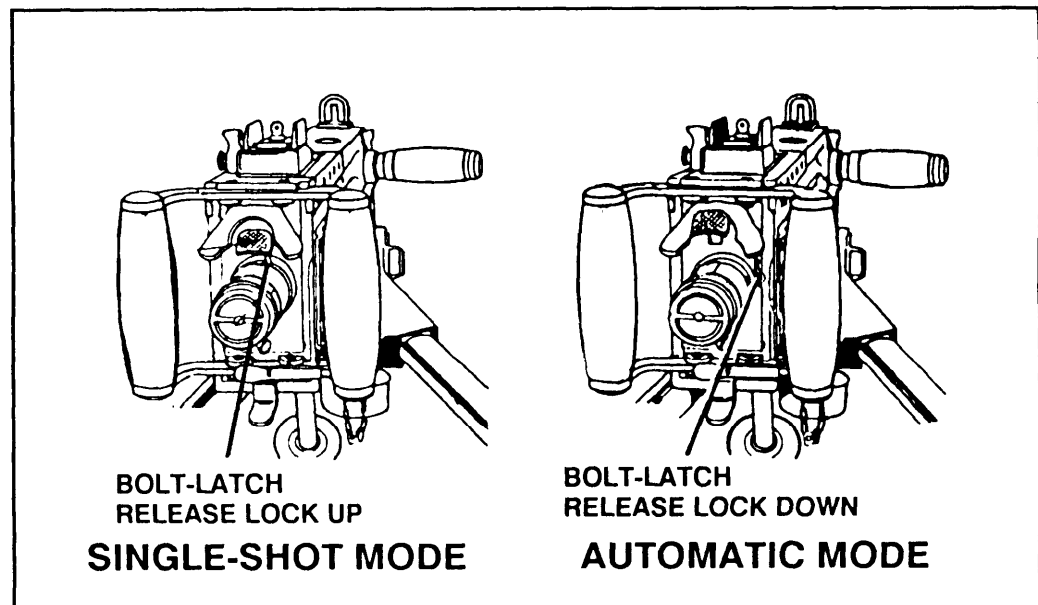

Figure 3-2. Firing modes.

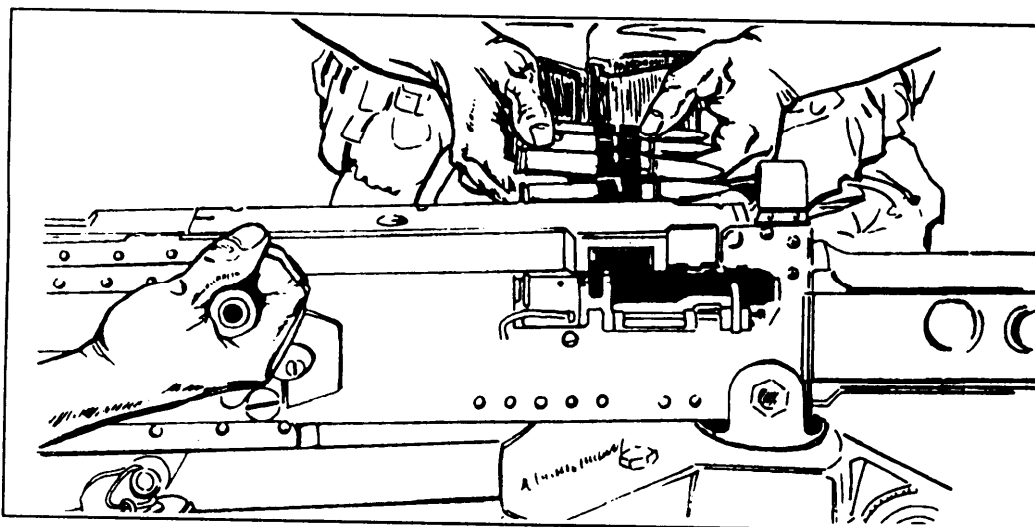

Figure 3-3. Loading the gun.

3-3. UNLOADING PROCEDURES

To unload the MG, the gunner must first ensure that the weapon is in the single-shot mode. The cover is then lifted and the assistant gunner removes the ammunition belt from the feedway. The bolt is then locked to the rear. Once the bolt is locked to the rear, the chamber and T-slot are examined to ensure that they are not holding rounds. In darkness, this must be done by feeling the areas. After the examination has been done (during training), a wooden block is inserted in the receiver between the bolt and the rear of the barrel, extending above and below the receiver about one inch. Then a cleaning rod is inserted in the muzzle end of the barrel and pushed through the bore until it can be seen in the receiver (Figure 3-4).

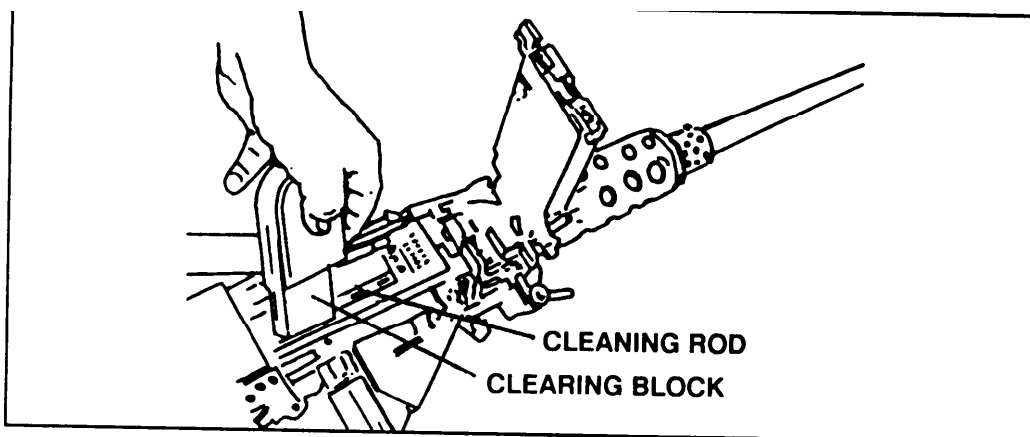

Figure 3-4. The clearing block.

3-4. CYCLE OF FUNCTIONING

The cycle of functioning is broken down into basic steps: feeding, cambering, locking, firing, unlocking, extracting, ejecting, and cocking. Some of these steps may occur at the same time.

a. **Feeding.** Feeding is the act of placing a cartridge in the receiver, approximately in back of the barrel, ready for cambering. When the bolt is fully forward and the top is closed, the ammunition belt is held in the feedway by the belt-holding pawl (Figure 3-5).

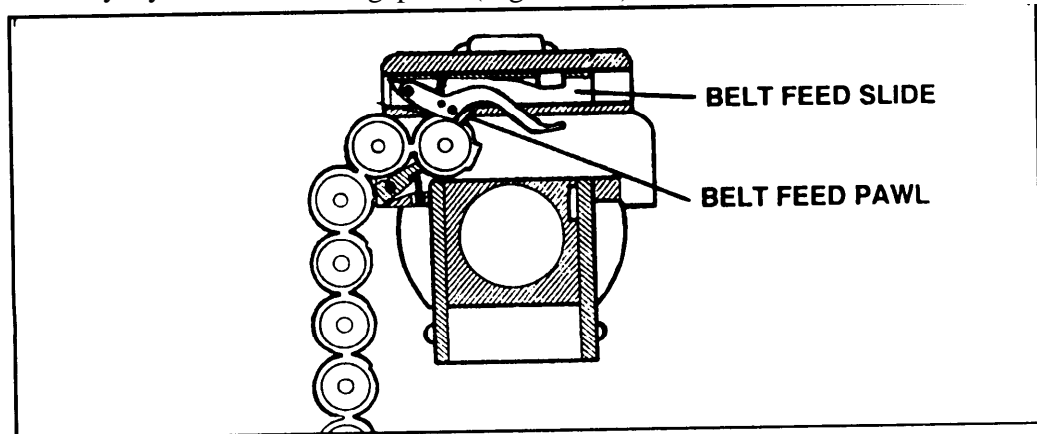

Figure 3-5. Feeding – step 1.

(1) As the bolt is moved to the rear, the belted ammunition is moved over and then held in a stationary position by the belt-holding pawl. At the same time, the belt-feed pawl rides up and over the link, holding the first round in place. When the bolt is all the way to the rear, the belt-feed slide moves out far enough to allow the belt-feed pawl spring to force the pawl up between the first and second rounds (Figure 3-6).

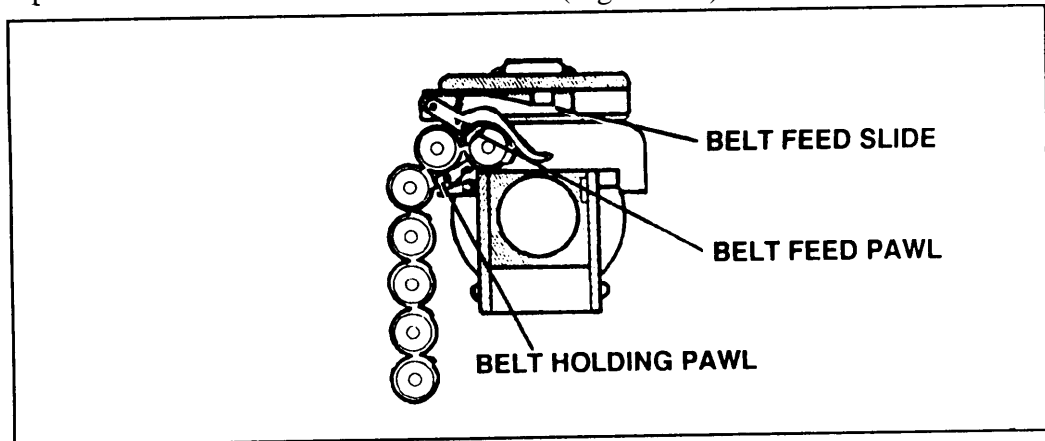

Figure 3-6. Feeding—step 2.

(2) As the bolt moves forward, the belt-feed slide is moved back into the receiver, pulling with it the next linked cartridge. When the bolt reaches the fully forward position, the belt-holding pawl will snap into place behind the second linked cartridge (Figure 3-7), holding it in place. The extractor will then grasp the rim of the first cartridge, preparing to release it from the belt on the next rearward motion (Figure 3-8).

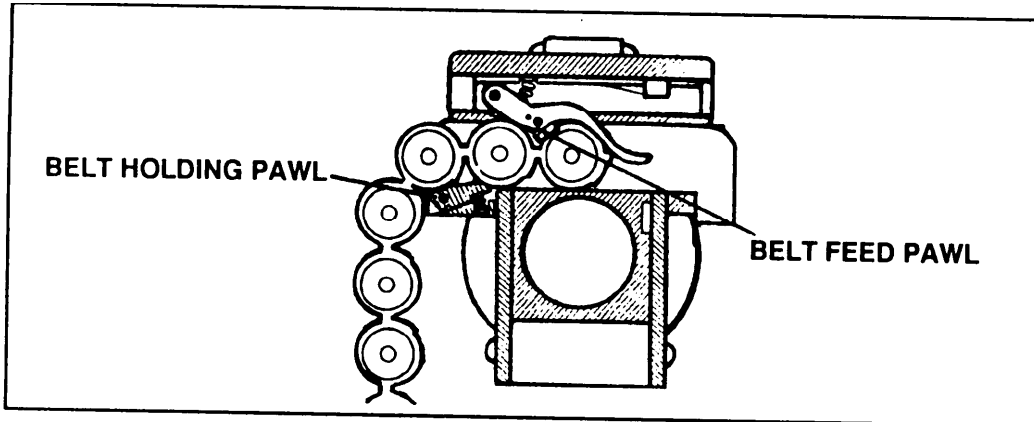

Figure 3-7. Feeding – step 3.

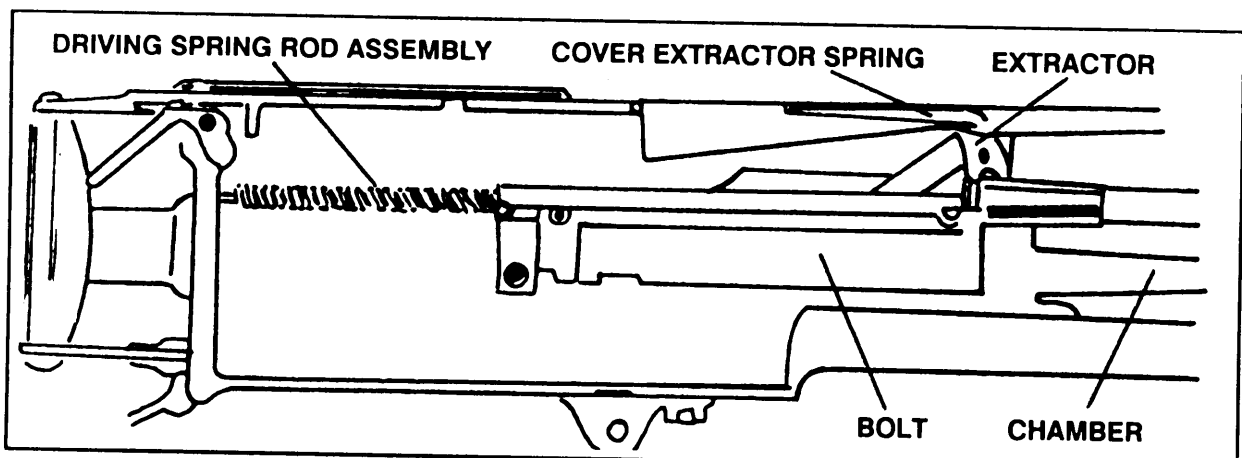

Figure 3-8. Feeding – withdrawing the first round from the feedway.

(3) As the bolt then moves to the rear, the extractor will pull the cartridge with it, releasing it from the belt. As it moves to the rear, the extractor is forced down by the extractor cam, causing the cartridge to be moved into the T-slot in the bolt face, preparing the cartridge to be chambered (Figure 3-9, page 3-6). It is connected under the extractor switch on the side of the receiver until it is repositioned by the forward movement of the bolt, and pressure of the cover extractor spring forces it over the next round.

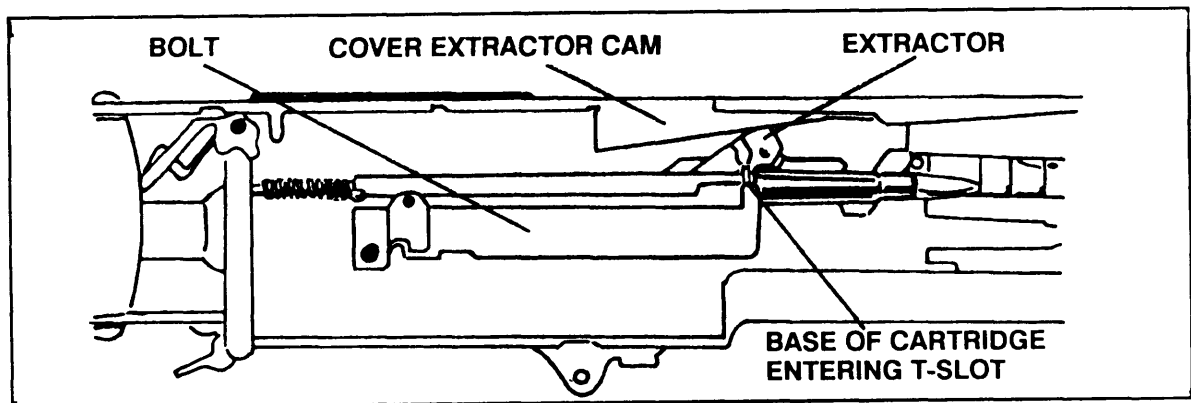

Figure 3-9. Feeding - cartridge entering the T-slot in the bolt.

b. **Cambering.** Cambering is placing the cartridge into the chamber of the weapon. During this cycle, the bolt moves forward, carrying the cartridge in the T-slot in a direct route to the chamber of the weapon. At the same time, the extractor rides up the extractor cam and when the bolt is fully forward, the extractor grasps the next linked cartridge (Figure 3-10).

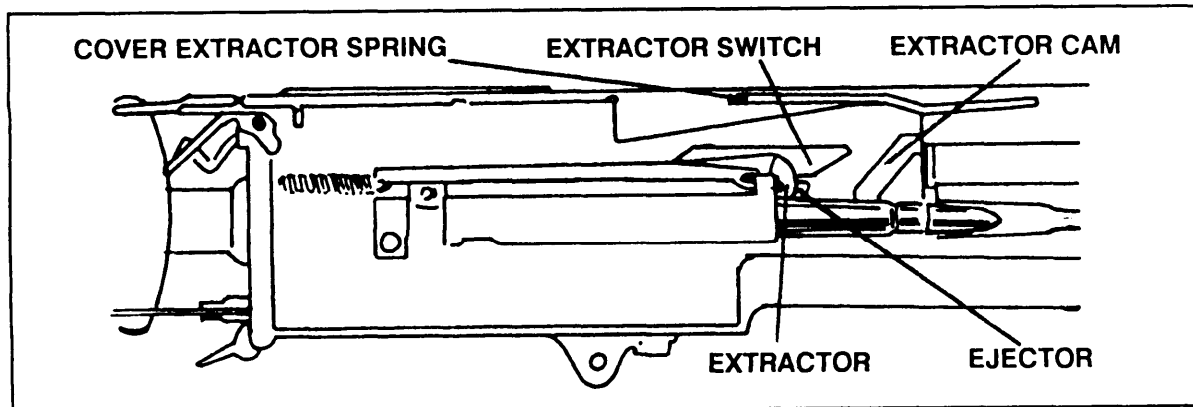

Figure 3-10. Cambering - new round aligned with the chamber.

c. **Locking.** The bolt is locked to the barrel and barrel extension.

(1) Initially, the bolt is forced forward in counter-recoil by the energy stored in the driving spring assembly and the compressed buffer disks. At the start of counter-recoil, the barrel buffer body tube lock keeps the accelerator tips from bounding up too soon and catching in the breech lock recess in the bolt. After the bolt travels forward about 5 inches, the lower rear projection of the bolt strikes the tips of the accelerator, turning the accelerator forward. This unlocks the barrel extension from the barrel buffer body group and releases the barrel buffer spring. The barrel buffer spring expands, forcing the piston rod forward.

(2) Since the cross groove in the piston rod engages the notch on the barrel extension shank, the barrel extension and barrel are also forced forward by the action of the barrel buffer spring. Some of the forward motion of the bolt is transmitted to the barrel extension through the accelerator. As the accelerator rotates forward, the front of the accelerator speeds up the barrel extension; at the same time, the accelerator tips slow down the bolt.

(3) Locking begins 1 1/8 inches before the recoiling groups (bolt, barrel extension, and barrel) are fully forward. The breech lock in the barrel extension rides up the breech lock cam in the bottom of the receiver into the breech lock recess in the bottom of the bolt, locking the recoiling groups together. The recoiling groups are completely locked together three-fourths of an inch before the groups are fully forward (Figure 3-11).

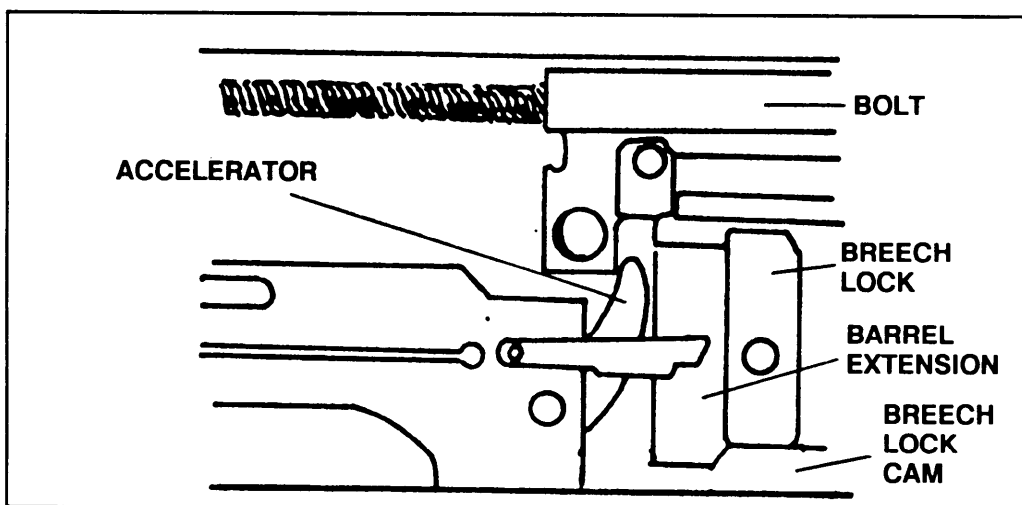

Figure 3-11. Locking – recoiling groups locked together.

d. **Firing.** The firing pin is released, igniting the primer of the cartridge.

(1) As the trigger is pressed down, it pivots on the trigger pin, so that the trigger cam on the inside of the backplate engages and raises the rear end of the trigger lever. This in turn pivots on the trigger lever pin assembly, causing the front end of the trigger lever to press down on the top of the sear stud. The sear is forced down until the hooked notch of the firing pin extension is disengaged from the sear notch. The firing pin and firing pin extension are driven forward by the firing pin spring; the striker of the firing pin hits the primer of the cartridge, firing the round (Figures 3-12 and 3-13, page 3-8).

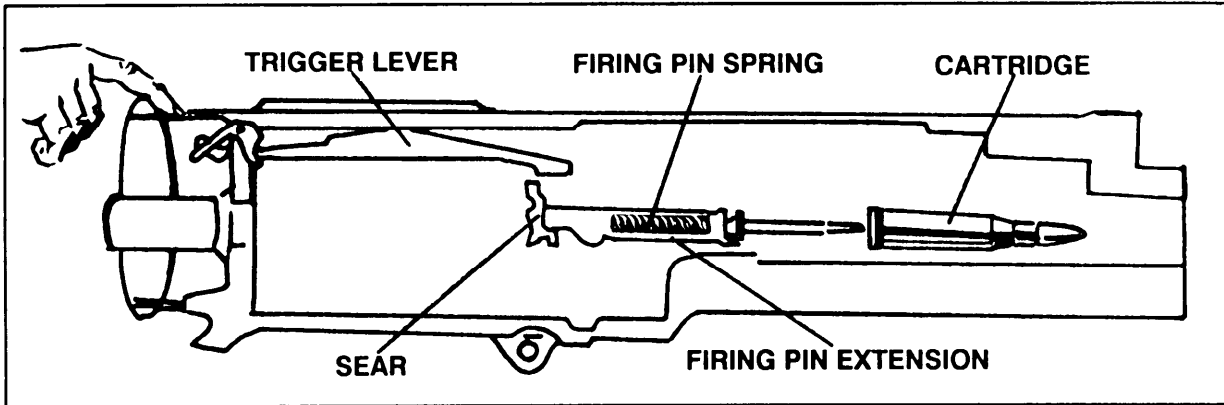

Figure 3-12. Firing – ready to fire.

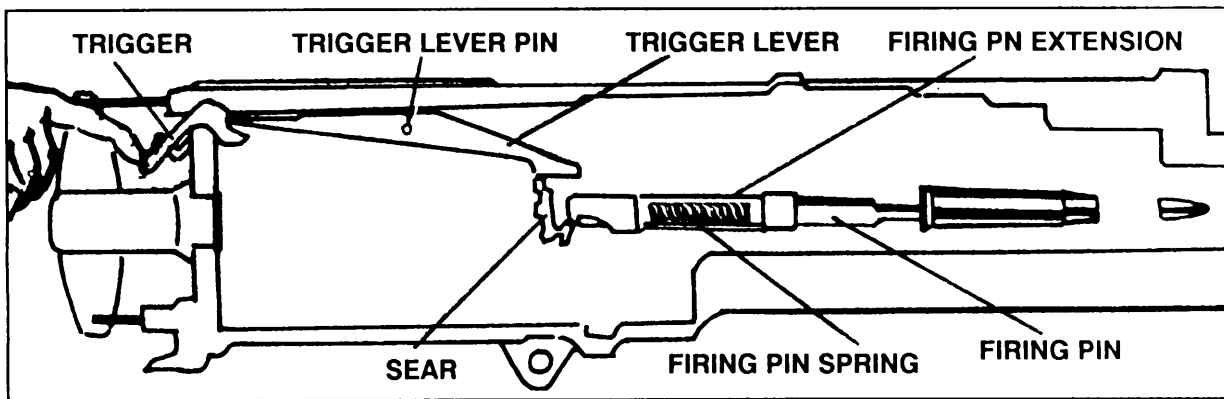

Figure 3-13. Firing – round ignited.

(2) For automatic firing, the bolt-latch release must be locked or held depressed, so that the bolt latch will not engage the notches in top of the bolt, holding the bolt to the rear as in single-shot firing. The trigger is pressed and held down. Each time the bolt travels forward in counter-recoil, the trigger lever depresses the sear, releasing the firing pin extension assembly and the firing pin. This automatically fires the next round when the forward movement of the recoiling groups is nearly completed. The gun should fire about one-sixteenth of an inch before the recoiling groups are fully forward. Only the first round should be fired with the parts fully forward. The gun fires automatically as long as the trigger and bolt latch are held down and ammunition is fed into the gun.

e. **Unlocking.** The bolt is unlocked from the barrel and barrel extension.

(1) At the instant of firing, the bolt is locked to the barrel extension and against the rear end of the barrel by the breech lock, which is on top

of the breech lock cam and in the breech lock recess in the bottom of the bolt. When the cartridge explodes, the bullet travels out of the barrel; the force of recoil drives the recoiling groups rearward. During the first three-fourths of an inch, the recoiling groups are locked together. As this movement takes place, the breech lock is moved off the breech lock cam stop, allowing the breech lock depressors (acting on the breech lock pin) to force the breech lock down, out of its recess from the bottom of the bolt. At the end of the first three-fourths of an inch of recoil, the bolt is unlocked, free to move to the rear independent of the barrel and barrel extension.

(2) As the recoiling groups move to the rear, the barrel extension causes the tips of the accelerator to rotate rearward. The accelerator tips strike the lower rear projection of the bolt, accelerating the movement of the bolt to the rear. The barrel and barrel extension continue to travel to the rear an additional three-eighths of an inch, or an approximate total distance of 1 1/8 inches until they are stopped by the barrel buffer assembly (Figure 3-14).

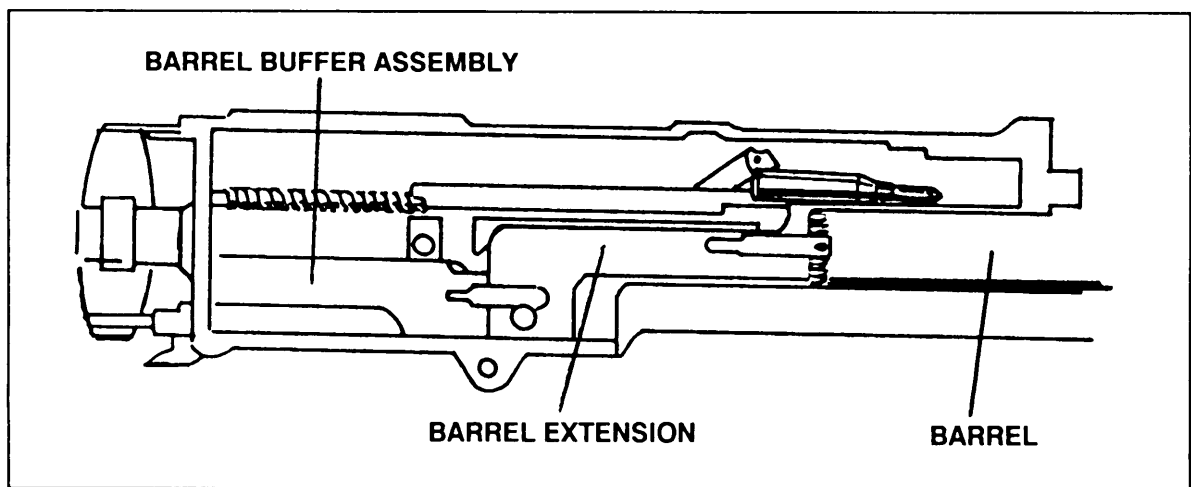

Figure 3-14. Unlocking – barrel and barrel extension stopped by the barrel buffer assembly.

(3) During the recoil of 1 1/8 inches, the barrel buffer spring is compressed by the barrel extension shank, since the notch on the shank is engaged in the cross groove in the piston rod head. The spring is locked in the compressed position by the claws of the accelerator, which engage the shoulders of the barrel extension shank. After its initial travel of three-fourths of an inch, the bolt travels an additional 6 3/8 inches to the rear, after it is unlocked from the barrel and barrel extension, for a total of

7 1/8 inches. During this movement, the driving springs are compressed. The rearward movement of the bolt is stopped as the bolt strikes the buffer plate. Part of the recoil energy of the bolt is stored by the driving spring rod assembly, and part is absorbed by the buffer disks in the backplate (Figure 3-15).

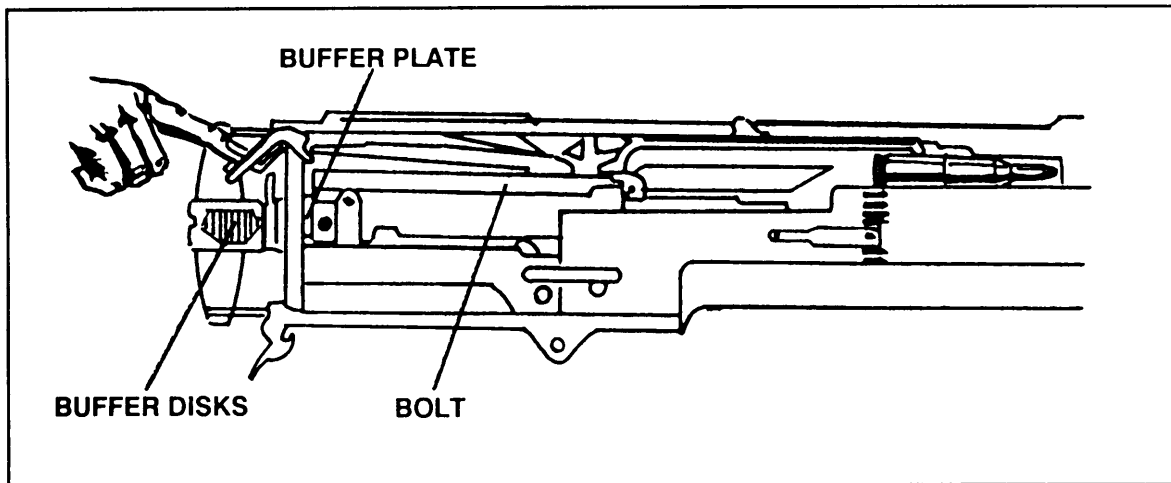

Figure 3-15. Unlocking – recoil movement completed.

f. **Extracting.** The empty cartridge case is pulled from the chamber.

(1) The empty case, held by the T-slot, has been expanded by the force of the explosion; therefore, it fits snugly in the chamber. If the case is withdrawn from the chamber too rapidly, it may be torn. To prevent this, and to ensure slow initial extraction of the case, the top forward edge of the breech lock and the forward edge of the lock recess in the bolt are beveled. As the breech lock is unlocked, the initial movement of the bolt away from the barrel and barrel extension is gradual.

(2) The slope of the locking faces facilitates locking and unlocking and prevents sticking. The leverage of the accelerator tips on the bolt speeds extraction after it is started by kicking the bolt to the rear to extract the empty case from the chamber.

g. **Ejecting.** The empty cartridge case is expelled from the receiver.

(1) As the bolt starts its forward movement (counter-recoil), the extractor lug rides below the extractor switch, forcing the extractor assembly farther down until the round is in the center of the T-slot of the bolt.

(2) The round, still gripped by the extractor, ejects the empty case from the T-slot. The last empty case of an ammunition belt is pushed out by the ejector.

h. Cocking. The firing pin is withdrawn into the cocked position.

(1) When the recoiling groups are fully forward, the top of the cocking lever rests on the rear half of the V-slot in the top plate bracket. As the bolt moves to the rear, the top of the cocking lever is forced forward. The lower end pivots to the rear on the cocking lever pin. The rounded nose of the cocking lever, which fits through the slot in the firing pin extension, forces the extension to the rear, compressing the firing pin spring against the sear stop pin (accelerator stop). As the firing pin extension is pressed to the rear, the hooked notch of the extension rides over the sear notch, forcing the sear down. The sear spring forces the sear back up after the hooked notch of the firing pin extension has entered the sear notch.

(2) The pressure of the sear and firing pin springs holds the two notches locked together. There is a slight overtravel of the firing pin extension in its movement to the rear to ensure proper engagement with the sear. As the bolt starts forward, the overtravel is taken up and completed when the cocking lever enters the V-slot of the top plate bracket, and is caromed toward the rear; pressure on the cocking lever is relieved as the bolt starts forward.

3-5. LEFT-HAND FEED

By repositioning some of the components, the MG is capable of alternate feed. Ammunition can be fed into the weapon from the right or left side of the receiver; however the Army uses only left-hand feed. (See Table 3-1).

PART	POSITION
Belt-feed lever, shoulder headless pin, and spring.	Upper (rear) hole; lug of feed lever is on left side of cover.
Belt-feed slide.	Feed pawl is on left side of cover.
Belt-feed pawl arm.	Arm toward latch end of cover, pointing right.
Cover latch shaft lever	Left side of cover.
Cartridge stops and link stripper.	Right-hand rear cartridge stop assembly and front cartridge stop on right side of feedway.
Retracting slide with handle.	Right sideplate.
Belt-holding pawl.	Left side of feedway.
Bolt switch.	Cam grove in line with "L" on bolt.

Table 3-1. Position of parts for left-hand feed.

DANGER

Clear the gun of ammunition before setting headspace.

3-6. HEADSPACE AND TIMING

Headspace is the distance between the face of the bolt and the base of the cartridge case, fully seated in the chamber. Timing is the adjustment of the gun so that firing takes place when the recoiling parts are in the correct position for firing. Because the cartridge is held by the T-slot of the bolt, headspace with the MG is measured as the distance between the rear of the barrel and the face of the bolt. This occurs when the recoiling parts are forward and there is positive contact between the breech lock recess in the bolt and the lock in the barrel extensions. Periodic calibration checks should be made of the gauge by direct support personnel at least annually.

WARNING

Firing a weapon that has improperly set headspace and timing could result in damage to the machine gun, or injury to the gunner. Damage may also occur in the trunnion block, base of the barrel, or face of the bolt. This warning applies whether the gun is firing service ammunition or M1E1 blanks. (The weapon has improper early timing when two rounds are fired – and firing stops.)

a. **Gauges.** The headspace and timing gauge consists of a headspace gauge and two timing gauges (Figure 3-16). These gauges provide an accurate means of checking the adjustment of headspace and timing.

NOTE: The headspace and timing gauge should be kept with the gun at all times.

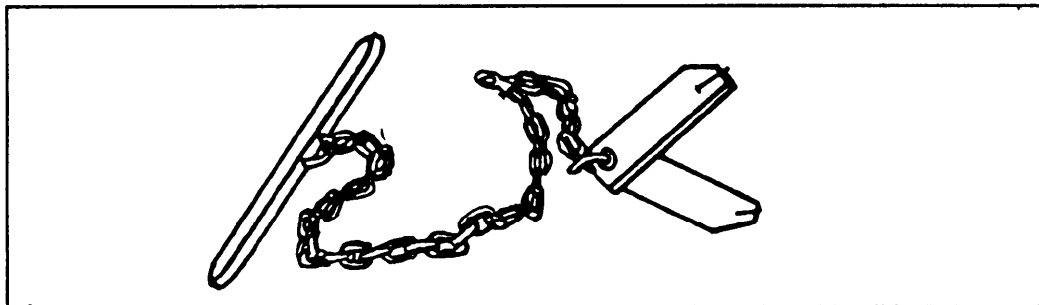

Figure 3-16. Headspace and timing gauge.

b. **Headspace.** Check and set headspace before firing, after assembling the gun, and after replacing the barrel or receiver group. Use the following procedures to set headspace.

(1) Raise the cover all the way up. Grasp the retracting slide handle (Figure 3-17). Using the retracting slide handle, retract the bolt until the barrel-locking-spring lug is centered in the 3/8-inch hole on the right side of the receiver (Figure 3-18).

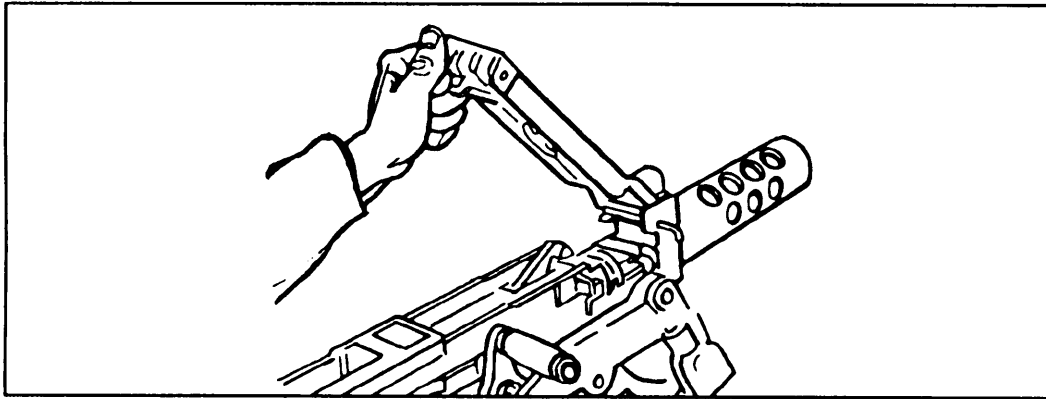

Figure 3-17. Raising the cover.

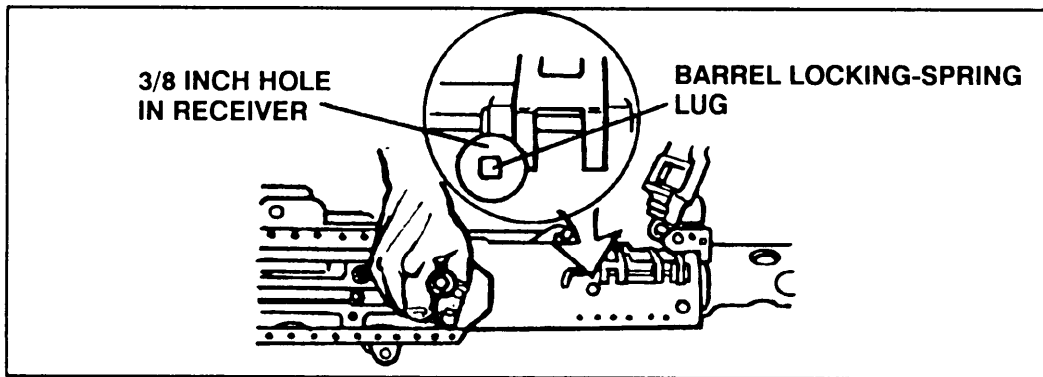

Figure 3-18. Retracting the bolt.

(2) Hold the bolt in this position and screw the barrel fully into the barrel extension (Figure 3-19).

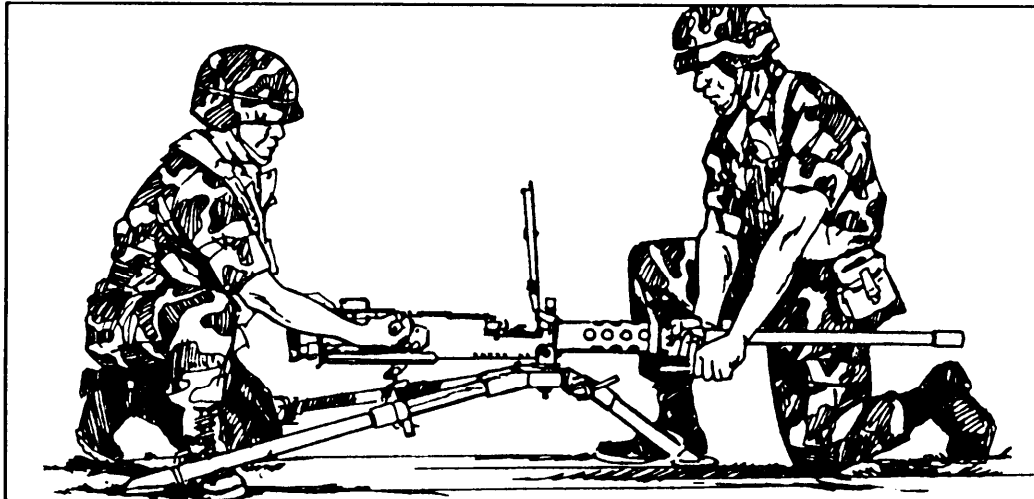

Figure 3-19. Screwing in the barrel.

WARNING

When resetting the headspace and timing of a gun that has been fired, use an asbestos mitt to avoid burns.

(3) With the bolt still retracted, unscrew the barrel two notches (clicks). Release the retracting slide handle and allow the bolt to go forward.

NOTE: At this point, check the barrel for rotation. Attempt to turn the barrel in either direction. The barrel should not turn. If the barrel does turn, stop here and check barrel notches and the barrel-locking spring for damage.

(4) Pull the bolt to the rear with the retracting slide handle and hold. This cocks the weapon. Otherwise, the headspace gauge will not fit.

(5) Holding the retracting slide handle, release the bolt, and slowly return the bolt fully forward (Figure 3-20). Do not press the trigger or let the bolt slam forward.

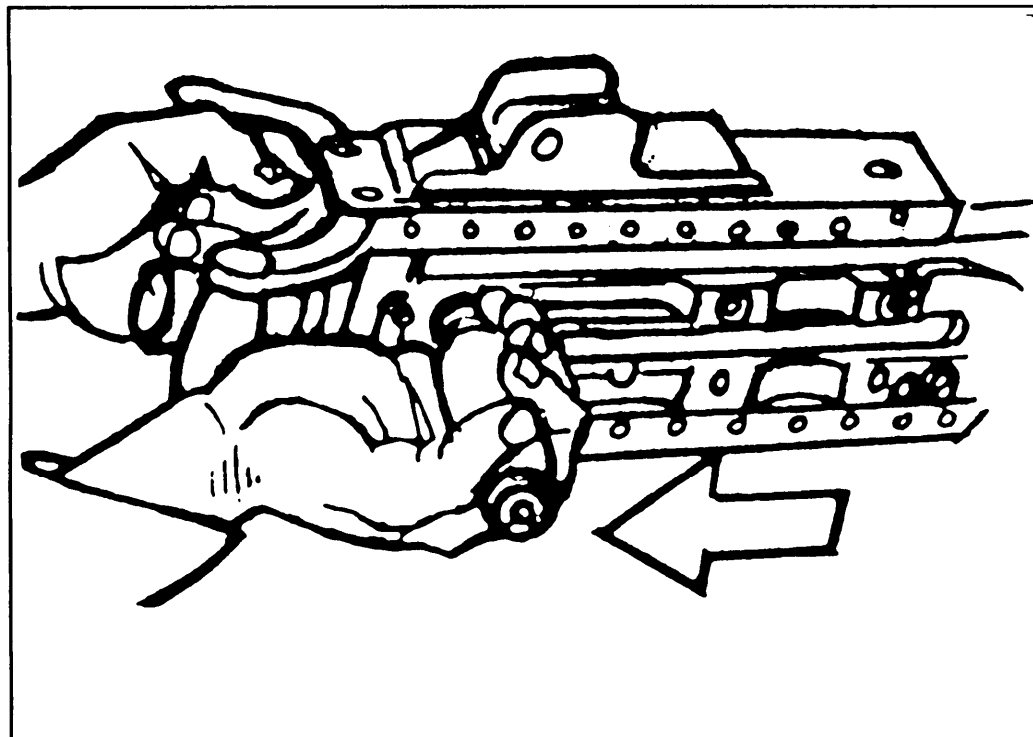

Figure 3-20. Releasing the bolt.

(6) Retract the retracting slide handle and separate the barrel extension from the trunnion block by a 1/16-inch gap (Figure 3-21).

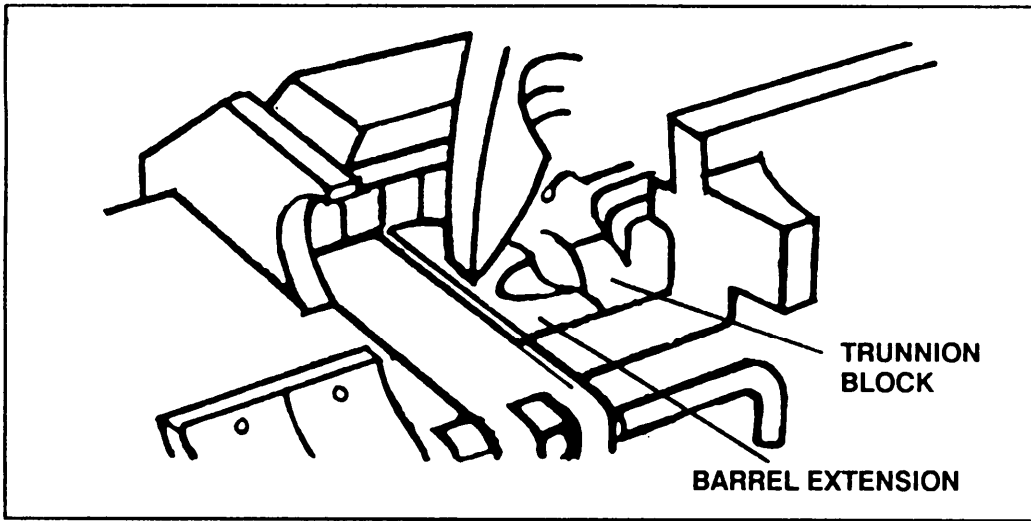

Figure 3-21. Setting the gap.

(7) Raise the extractor out of the way to clear the top of the T-slot and try both ends of the go/no-go gauge as shown in Figure 3-22.

NOTE: Insert the go end of the gauge between the face of the bolt and the end of the barrel all the way up to the ring.

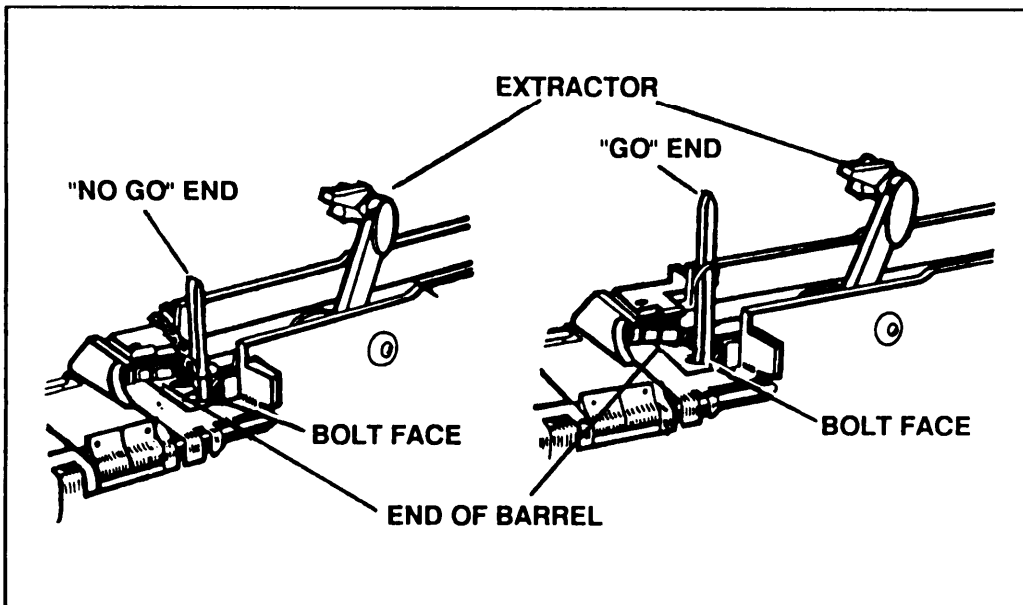

Figure 3-22. Using the gauge.

(8) If the go end of the gauge enters the T-slot freely to the center ring of the gauge, and the no-go end will not enter, headspace is correct. Remove gauge. Headspace setting is now complete. If the go end of the gauge will not enter the T-slot freely, headspace is too tight. Continue as follows.

(9) Retract the bolt so you can see the barrel-locking lug in the center of the 3/8th-inch alignment hole on the right side of the receiver.

(10) Unscrew the barrel one notch (click).

(11) Return the bolt fully forward.

(12) Recheck headspace (step 9).

(13) Repeat steps 10 through 13 until the go gauge fits but the no-go gauge does not fit.

NOTE: You should not have to unscrew the barrel more than five notches (clicks) beyond the first setting of two clicks. If this condition does occur, turn in the machine gun to your unit armorer for inspection.

(14) If the no-go end of the gauge enters the T-slot, headspace is too loose. Adjust it using the same procedures as above, screwing the barrel into the barrel extension rather than out.

(15) Repeat steps 10 through 13, one click at a time, until the no-go gauge does not fit but the go gauge does fit.

c. **Timing.** Timing is the adjustment of the weapon so that firing takes place when the recoiling parts are between .020 and .116 inch out of battery to prevent contact between the front end of the barrel extension and the trunnion block. Use the following procedures to set timing.

WARNING

Make sure the gun is clear of ammunition before starting.

(1) Check headspace first as previously described.

(2) Pull the bolt to the rear with the retracting slide handle and then ease bolt fully forward to cock the machine gun.

(3) Grasp the retracting slide handle and retract the bolt just enough (1/16 inch) to insert the no-fire gauge between the barrel extension and the trunnion block. Release the retracting slide handle (Figure 3-23).

(4) Depress the trigger. Gun should not fire.

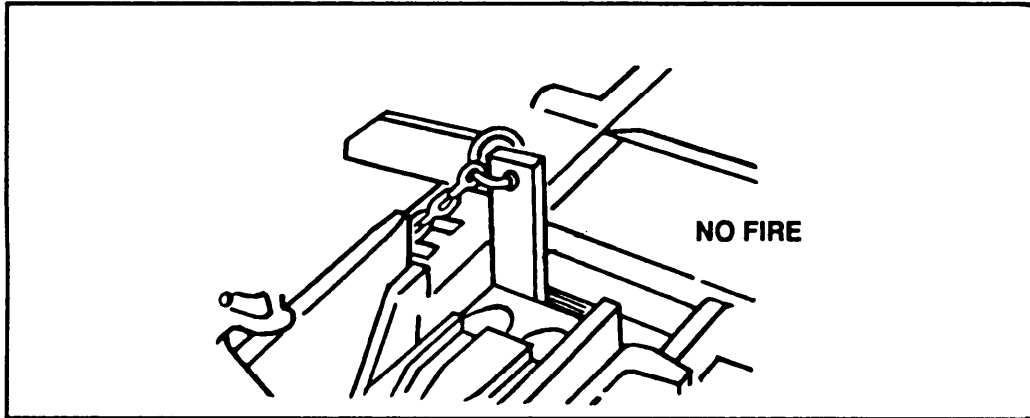

Figure 3-23. Inserting the no-fire gauge.

NOTE: Insert timing gauge with bevel against barrel notches.

NOTE: If the gun does not fire, go to step 5. If the gun does fire, you have early timing. Go on to steps 7 through 14.

(5) Grasp the retracting slide handle and retract the bolt just enough to remove the no-fire gauge and insert the fire gauge in the same place (Figure 3-24). Release the retracting slide handle.

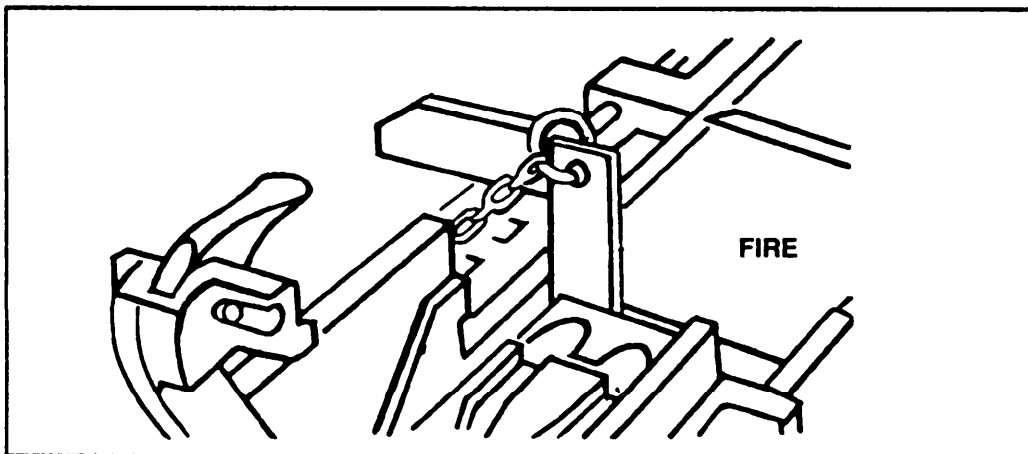

Figure 3-24. Inserting the fire gauge.

(6) Depress the trigger. Gun should fire. If it does, timing adjustment is now complete.

NOTE: If the gun does not fire, you have late timing. Go to steps 7 through 14.

(7) Remove the gauge, cock the gun, and return the bolt forward

(8) Insert the fire gauge.

- (9) Remove the backplate.
- (10) Screw the timing adjustment nut all the way down until it touches the trigger lever (Figure 3-25).

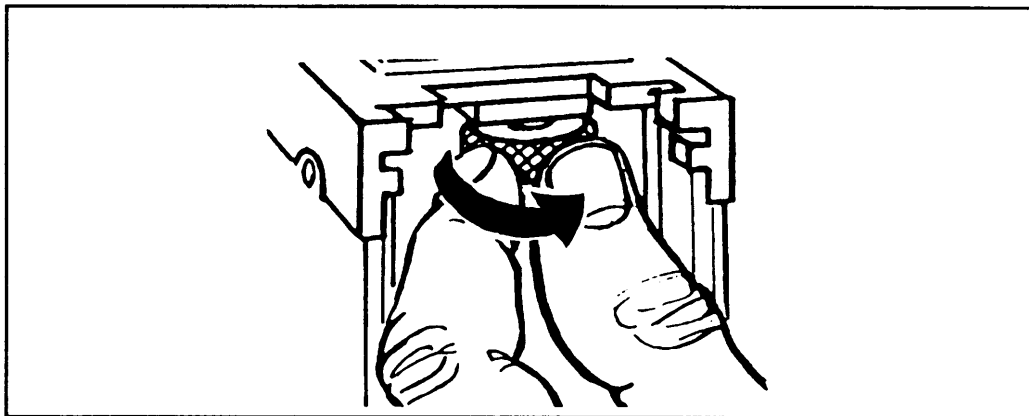

Figure 3-25. Adjusting the timing nut.

WARNING

Never cock the gun with the backplate off.

(11) Try to fire the MG by pushing up on the rear of the trigger lever. Gun should not fire.

(12) Screw the timing adjustment nut up (to the right) one click at a time. Push up on the trigger lever after each click. Keep doing this until the gun fires.

(13) Turn the timing adjustment nut no more than two more clicks up (to the right).

(14) Remove the gauge, replace the backplate, and pull the bolt to the rear to cock the machine gun. Ease the bolt forward with the charging handle. Do not allow the bolt to slam forward.

(15) Recheck the timing with the fire/no-fire gauge twice after the backplate is installed to ensure that the setting is correct.

d. **Field Expedient Methods.** When a go/no-go gauge is not available, you can still set the headspace and timing using field expedient methods. However, this method should be used only in combat.

(1) *To set headspace:*

(a) Raise the cover and retract the bolt in the normal manner until the barrel-locking-spring lug is centered in the 3/8-inch hole on the right side of the receiver.

(b) Hold the bolt in this position and screw the barrel fully into the barrel extension; then unscrew the barrel two clicks or notches.

(2) *To set timing:*

(a) Use a dog tag or a dime as a fire gauge.

(b) Use a nickel and a dime or four dog tags as a no-fire gauge.

(c) Set the timing using the normal procedure.

(3) *To check for correct settings:*

(a) Attempt to fire the weapon. If it fires sluggishly, clear the weapon then unscrew the barrel one more notch.

(b) Recheck the rate of fire. Repeat the procedures in paragraph (1); however, do not exceed two more clicks.

(c) Do not unscrew the barrel more than one notch between test firings.

CHAPTER 4

PERFORMANCE PROBLEMS AND DESTRUCTION

This chapter discusses the malfunctions, stoppages, immediate actions, remedial actions, and destruction procedures of the MG. All corrective actions must comply with safety procedures.

4-1. MALFUNCTIONS

A malfunction is any failure of the gun to function satisfactorily. Examples of malfunctions are:

a. **Failure to Function Freely.** Sluggish operation is usually due to human failure to eliminate excessive friction caused by dirt, lack of proper lubrication, burred parts, incorrect headspace adjustment, or incorrect timing.

b. **Uncontrolled Automatic Fire.** Uncontrolled automatic fire (runaway gun) is when fire continues even when the trigger or trigger control mechanism is released. If the cause is present before the gun is fired, the gun will start to fire when the recoiling groups move into battery the second time. If the defect occurs during firing, the gun will continue firing when the trigger control mechanism is released. A runaway gun may be caused –

- By a bent trigger lever, forward end of the trigger lever sprung downward.
- By burred beveled contacting surfaces of the trigger lever and sear.
- By a jammed or broken sideplate trigger.

To stop the uncontrolled automatic fire:

- (1) Keep the gun laid on target.
- (2) Twist the belt, causing the gun to jam.
- (3) Caution, do not unlatch the cover.
- (4) Wait 5 minutes to guard against cook off.
- (5) Clear weapon, replace broken, worn, or burred parts. Check the sideplate trigger and trigger control mechanism, when applicable.

4-2. STOPPAGES

A stoppage is any interruption in the cycle of operation caused by the faulty action of the gun or ammunition. Stoppages are classified as follows:

- a. **Failure to Feed.** Prevents the round from being properly positioned in the receiver group.
- b. **Failure to Chamber.** Prevents the complete chambering of the round.
- c. **Failure to Lock.** Prevents the breech lock from correctly entering its recess in the bolt.
- d. **Failure to Fire.** Prevents the ignition of the round.
- e. **Failure to Unlock.** Prevents the breech lock from moving out of its recess in the bolt.
- f. **Failure to Extract.** Prevents the extraction of the expended cartridge from the chamber.
- g. **Failure to Eject.** Prevents the ejection of the expended cartridge from the receiver.
- h. **Failure to Cock.** Prevents the firing pin extension from being engaged with the sear.

Table 4-1 lists the causes of most stoppages.

NATURE OF STOPPAGE	USUAL CAUSES	OTHER CAUSES
Failure to feed.	Defective ammunition belt. Defective feed mechanism. Defective extractor.	Improperly loaded belt. Short round
Failure to chamber.	Broken part or obstruction in T-slot or chamber. Separated (ruptured) case.	Thick or thin rim, bulged round, protruding primer.
Failure to lock	Incorrect headspace.	Broken parts. Battered breach lock. Battered breach lock cam. Faulty breach lock cam adjustment.
Failure to fire.	Defective parts in firing mechanism. Defective ammunition. Incorrect timing.	
Failure to unlock.	Broken parts in receiver.	Worn or faulty breach lock cam, or faulty adjustment.
Failure to extract.	Dirty chamber.	Defective cartridge case.
Failure to eject.	Defective ejector.	Burred T-slot.
Failure to cock.	Broken sear. Worn sear notch. Weak sear spring. Worn hooked notch on firing pin extension.	Broken cocking lever.

Table 4-1. Stoppages and their causes.

4-3. IMMEDIATE ACTION

The first thing to do when a stoppage occurs is to apply immediate action, which is the prompt action taken by the firer to reduce a stoppage.

Immediate action is performed by the gunner; however, every crewmember must be trained to apply immediate action. The following procedures will assist in reducing most stoppages without analyzing their cause in detail.

WARNING

Failure to follow procedures may result in damage to weapon and injury to personnel.

a. If gun fails to fire, take the following action:

(1) Wait 5 seconds; a hangfire maybe causing the misfire. In the next 5 seconds, pull the bolt to the rear (check for ejection and feeding of belt), release it, re-lay on the target, and attempt to fire. If the bolt-latch release and trigger are depressed at the same time, the bolt goes forward and the weapon should fire automatically.

(2) If the gun again fails to fire, wait 5 seconds, pull the bolt to the rear (engage with bolt latch if applicable), and return the retracting slide handle to its forward position. Open the cover and remove the belted ammunition. Inspect the gun to determine the cause of stoppage.

b. A hangfire or cookoff can cause injury to personnel or damage to the weapon. To avoid these, the gunner must take the following precautions:

(1) Always keep the round locked in the chamber the first 5 seconds after a misfire occurs. This prevents an explosion outside of the gun in event of a hangfire.

(2) If the barrel is hot, the round must be extracted within the next 5 seconds to prevent a cookoff. When more than 150 rounds have been fired in a 2-minute period, the barrel is hot enough to produce a cookoff.

(3) If the barrel is hot and the round cannot be extracted within the 10 seconds, it must remain locked in the chamber for at least 5 minutes, to guard against a cookoff.

(4) Keep the gun cover closed during the waiting periods.

4-4. REMEDIAL ACTION

When immediate action does not correct the malfunction, the quickest way to resume firing is to replace the defective part.

a. **Removal of a Cartridge from the T-Slot.** If the cartridge does not fall out, hold the bolt to the rear, and with the extractor raised, use a screwdriver to push the cartridge out the bottom of the receiver.

b. **Removal of a Ruptured Cartridge.** A ruptured (separated) cartridge case may be removed with a cleaning rod or ruptured cartridge extractor. When using the ruptured cartridge extractor, raise the cover and pull the

bolt to the rear. Place the extractor in the T-slot of the bolt in the same manner as that of a cartridge, so that it is held in line with the bore by the ejector of the extractor assembly of the gun. With the extractor aligned with the bore and held firmly in the T-slot, let the bolt go forward into the ruptured case, and the shoulders will spring out in front of the case. Pull the bolt to the rear and remove the ruptured case and extractor (Figures 4-1 and 4-2).

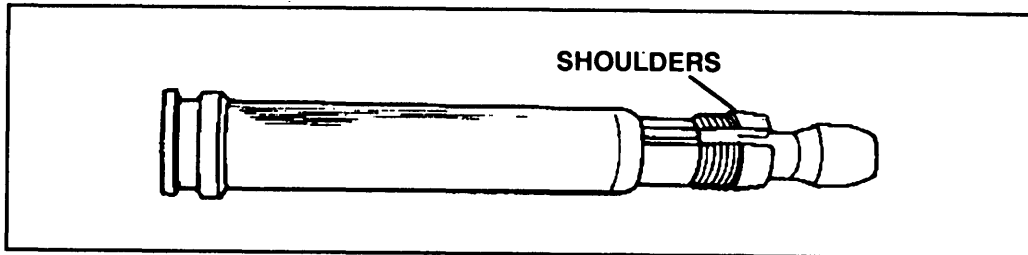

Figure 4-1. The ruptured cartridge case extractor.

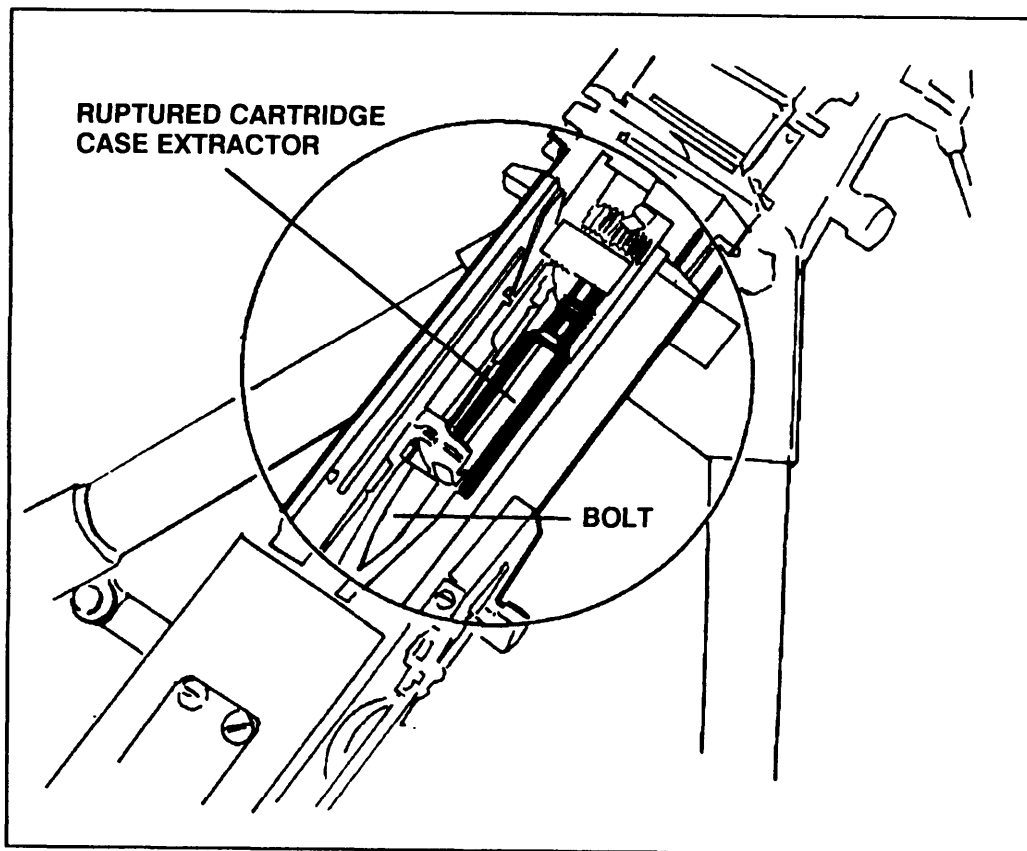

Figure 4-2. Ruptured cartridge case extractor aligned with the chamber.

4-5. DESTRUCTION PROCEDURES

The decision to destroy the gun to prevent its capture and use by the enemy is a command decision. It will be ordered and carried out only on authority delegated by the major unit commander.

- Destroy the machine gun and mount only when they are subject to capture or abandonment. Destruction must be as complete as circumstances permit.
- Lacking time for complete destruction, destroy the parts essential to operation of the gun, beginning with those parts most difficult for the enemy to duplicate.
- Destroy the same parts of each gun to prevent the reconstruction of a complete gun from several damaged guns.

The following methods may be used to destroy specific components of the MG.

a. **Gun.** Field strip the gun. Use the barrel as a sledge. Raise the cover and smash the cover forward and down toward the barrel support. Smash the backplate group. Remove the firing pin from the bolt; place the striker in the hole in the face of the bolt and bend it until broken. Remove the barrel buffer tube lock assembly from the barrel buffer body group and bend and deform it. Smash and bend the breech lock depressors. Place the barrel extension in the rear of the receiver with the barrel extension shank protruding; knock off the shank by striking it with the barrel from the side. Deform and crack the receiver by striking it with the barrel at the sideplate corners nearest the feedway. Smash the extractor.

b. **Tripod Mount, M3.** Leave the pintle on the tripod by removing the pintle bolt from the gun. Use the barrel as a sledge. Strike the sides of the pintle and deform it. Fold the trail legs and turn the mount over. Stand on the folded trail legs and knock off the pintle latch (pintle lock release cam). Smash the elevating mechanism with the barrel. If possible, smash the rear legs to prevent unfolding.

c. **Antiaircraft Mount, M63.** Remove the sideplate trigger control mechanism from its container or the gun, and deform it by using the barrel. Lock the cradle and yoke assembly in the horizontal position and beat the trigger frame assembly and cradle until they are bent down along the elevator assembly. Strike the elevator from the side with the barrel until it is bent so that the elevator will not rotate in the base.

d. **Spare Parts.** Destroy the bolt, barrel extension, firing pins, and barrel buffer groups. Break or deform all other parts.

e. **Ammunition.** When time permits and material is available, destroy ammunition by burning. Unpack all ammunition from boxes or cartons,

stack the ammunition in a heap and, using flammable material available, ignite and take cover immediately.

f. **Burning.** To destroy the gun by burning, place a thermite grenade in the receiver on the bolt (with the cover resting on the grenade) and fire the grenade. (This method may require the use of more than one grenade.) Remove the backplate group, place a thermite grenade in the rear of the receiver and fire the grenade.

g. **Disposal.** Bury in suitable holes, or dump parts into streams, mud, snow, sumps, latrines, or scatter the parts over a wide area.

CHAPTER 5

MARKSMANSHIP TRAINING

The procedures, exercises, and techniques for implementing a proper marksmanship program are based on the concept that all machine gunners must understand common firing principles, be proficient marksmen, and be confident in applying these skills in combat. This depends on their understanding of the machine gun and their application of marksmanship fundamentals. Proficiency is accomplished through practice that is supervised by qualified trainers and through objective performance assessments by the unit leaders. The structure of this chapter is in four sections: planning, fundamentals, basic marksmanship, and advanced gunnery. All advanced exercises are conducted under conditions that are as much like tactical conditions as possible. (See Appendix B for training aids and devices.)

Section I. PLANNING

The planning of MG training is no different from other marksmanship training. Guidelines are provided to assist the trainers in understanding, preparing, and ensuring that all training is conducted to standard. This section addresses the objectives, the responsibilities of the commanders, and the phases of training. It also introduces the training devices that assist in training, and designates when remedial and sustainment training should be conducted.

5-1. OBJECTIVES

The objectives of the MG training program are to guide the trainers, leaders, and gunners through a sequence of training to standard that produces a gunner who is able to maintain the gun and effectively engage targets in combat.

5-2. COMMANDER'S RESPONSIBILITIES

The responsibilities of the commander are to ensure the instructors and their assistants are thoroughly trained and rehearsed in the planning, knowledge, and presentation of all MG training. He will ensure that safety is emphasized and never overlooked during training. Serviceable weapons

are a must for good training and commanders must make sure they are used properly. He also ensures sufficient time is scheduled.

5-3. PHASES OF TRAINING

The initial training strategy is divided into three phases of marksmanship instruction — the fundamental phase, the basic marksmanship phase, and the advanced gunner phase. Gunner safety is continuously stressed during all phases of training.

a. In the fundamental phase, the gunner learns the necessary common skills, such as dry-fire exercises, preparation of positions, manipulation of the T&E, range determination, and sighting and aiming. The gunner must master these skills before he is allowed to progress to the basic marksmanship phase.

b. During the basic marksmanship phase, the gunner learns the basics of loading, zeroing, laying, and engaging of single and multiple targets from the tripod and vehicle mode.

c. The advanced gunnery phase trains the gunner in engaging moving targets, night firing, NBC firing, mounted firing, and firing using fire commands. The gunner will be placed under the stress and strain of simulated combat conditions.

5-4. SUSTAINMENT TRAINING

Once individuals and units have trained to a required level of proficiency, leaders must structure collective and individual training plans to conduct critical task training at the frequency necessary for the sustainment training strategy. Mission training plans and individual training evaluation programs help achieve and sustain collective/individual proficiency. Sustainment training prevents skill degradation. Army units must be prepared to accomplish their wartime missions at any time – they cannot rely on infrequent peaking to the appropriate level.

5-5. REMEDIAL TRAINING

Remedial training will be conducted in any of the phases of training where the gunner does not meet the standard. The trainer must be instantly aware of any gunner that seems to be having trouble. Once the problem has been identified, the gunner should be retrained as soon as possible so that he will maintain the same level of proficiency as the other gunners.

Section II. FUNDAMENTALS

The fundamentals are necessary basic skills that a gunner must be trained in before he can be expected to effectively engage targets. Personnel conducting marksmanship training must fully understand the fundamentals and be well rehearsed in applying them. The basics in MG training are assuming a proper firing position, sighting, aiming, determining range, and manipulating the T&E mechanism.

5-6. FIRING POSITIONS

Before a gunner can hit targets, he must learn to get behind the weapon in a position that allows him to be comfortable, affords him protection, and enhances mission accomplishment.

a. The tripod firing positions are prone, sitting, and standing. They are assumed in the following manner.

(1) The prone position is used when firing from the tripod that is set in a low position. It is assumed by lying on the ground directly behind the gun. The gunner then spreads his legs a comfortable distance apart with his toes turned outward. His left elbow rests on the ground, and his left hand grasps the elevating handwheel of the T&E. His right hand lightly grasps the right spade grip with his right thumb in a position to press the trigger. The position of his body can then be adjusted to position his firing eye in alignment with the sights of the weapon (Figure 5-1).

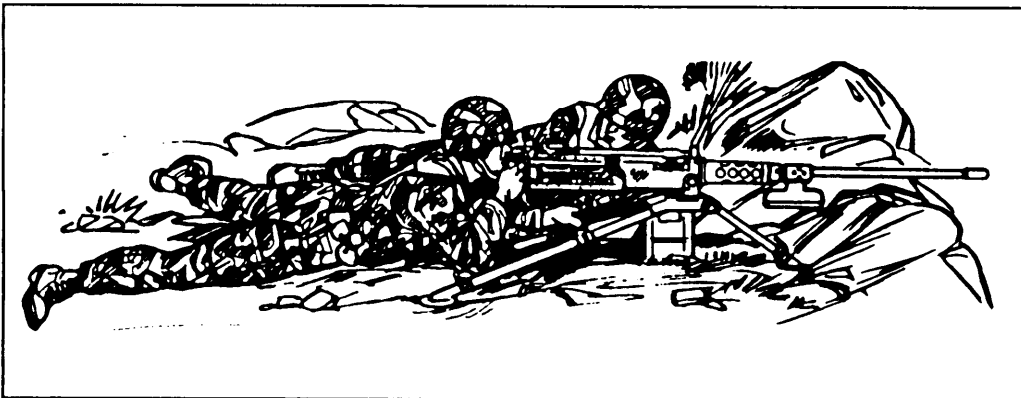

Figure 5-1. Prone position with tripod mount.

(2) The sitting position can be used when the tripod is set in a high or low position. The gunner sits directly behind the gun between the legs of the tripod. He may extend his legs under the tripod or cross them, depending on his physique. The gunner then places both elbows on the inside of his thighs to get the best support. He grasps the elevating

handwheel of the T&E with the left hand, and lightly grasps the right spade grip with his right hand. He must ensure that the right thumb is in position to press the trigger (Figure 5-2).

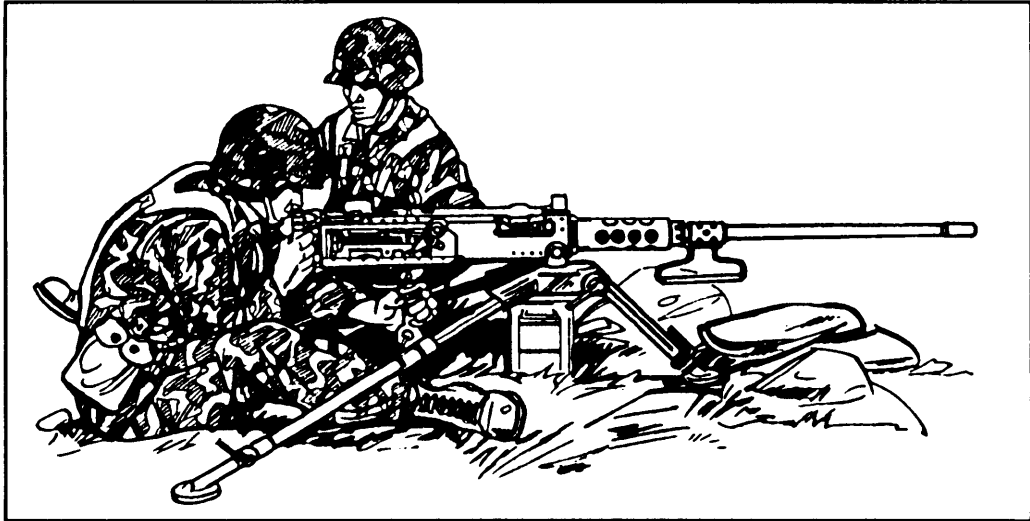

Figure 5-2. Sitting position with tripod mount.

(3) The standing position is used when the gunner is firing from a fighting position. This position is assumed by standing directly behind the gun with the feet spread a comfortable distance apart. The gunner grasps the elevating handwheel of the T&E with the left hand. He lightly grasps the right spade grip with the right hand, ensuring that the right thumb is in a position to press the trigger. Adjustment of the body is allowed in order to align the firing eye with the sights on the weapon (Figure 5-3).

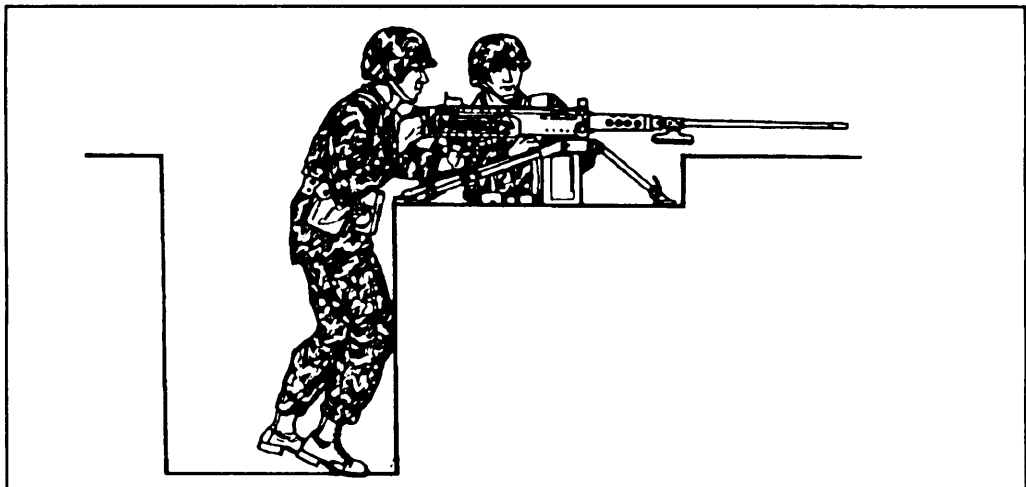

Figure 5-3. Standing position with tripod mount.

b. The vehicular firing position for the MG is standing. It is assumed by constructing a solid platform to stand on, using sandbags or ammunition boxes; or, in the case of the M113 APC, using the commander's seat. The gunner must then ensure that his platform is high enough to place the spade grips of the gun about chest high. He grasps the spade grips with both hands and places both thumbs in a position to press the trigger. The gunner holds the gun tightly to his chest for stabilization; his elbows should be locked tightly to his sides. He sights over the weapon and adjusts his position by flexing his knees and leaning forward to absorb any recoil (Figure 5-4).

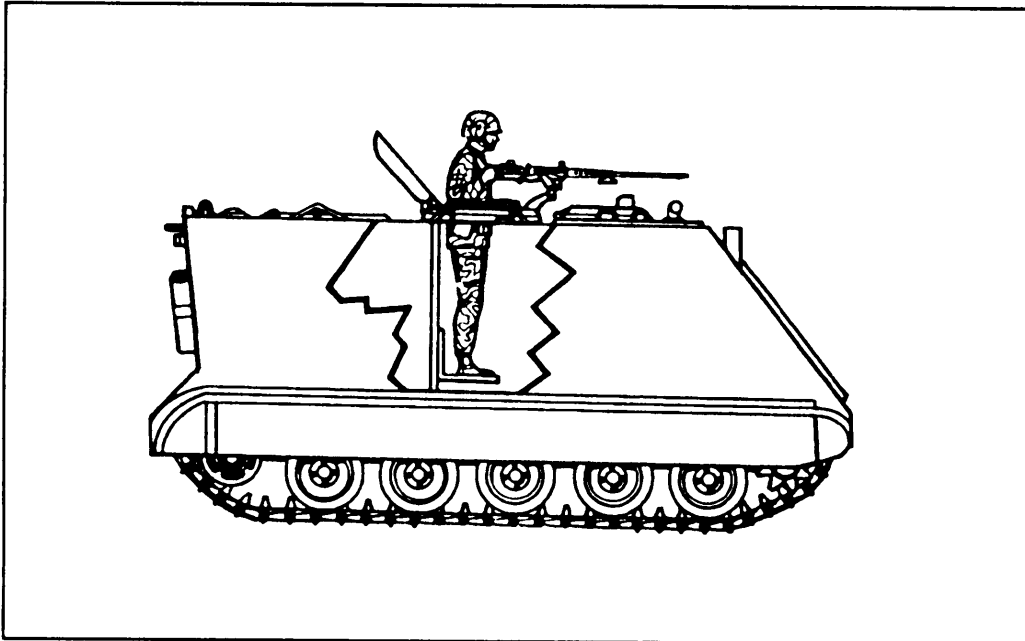

Figure 5-4. Standing position using cupola mount.

c. The anti-aircraft firing position uses a standing position when firing from the M63 mount. To assume the position, the gunner stands with his feet spread comfortably apart with his shoulders squarely behind the gun (Figure 5-5, page 5-6). When the gunner is engaging aerial targets, he grasps the upper extension handles with both hands. When engaging low-level aircraft or ground targets, he grasps the lower extension handles with both hands.

NOTE: The kneeling position may be used; it has the advantage of presenting a lower profile of the gunner and also aligns the gunner's eye closer to the axis of the barrel.

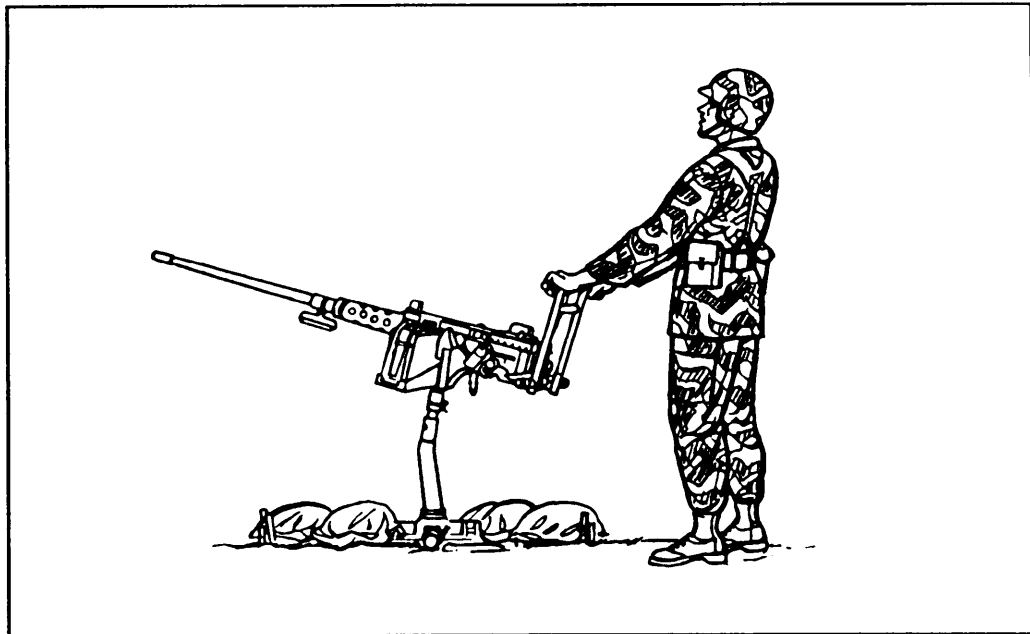

Figure 5-5. Antiaircraft firing position.

5-7. DRY-FIRE TRAINING

Dry-fire training is designed to teach the gunner the essentials of MG gunnery, including safety. Dry-fire training also includes sighting, aiming, sight setting, laying, manipulating the gun, manipulating the T&E mechanism, and determining the range. Thorough, carefully supervised training of these essentials is necessary to conserve time and ammunition during live fire. Practical exercises should be used to determine gunners' proficiency. Mastery of these skills is a must before the gunner is allowed to move on to the next phase of training. Practice is a must to achieve mastery.

a. **Sighting and Aiming.** Sighting is the ability of the gunner to use correct sight alignment and correct sight picture to engage targets.

(1) The first step in proper sighting is finding a natural, comfortable spot where the gunner is able to see the front sight blade through the rear peep sight. It is important the gunner understands that the spot he chooses to sight from must be constant throughout his firing.

(2) The second step in sighting is to move the weapon until the top center of the front sight blade is exactly in the center of the rear sight peep hole. The gunner can achieve this by drawing imaginary lines that bisect in the center of the rear peephole and then placing the top of the front sight blade center of them. This is correct sight alignment (Figure 5-6).

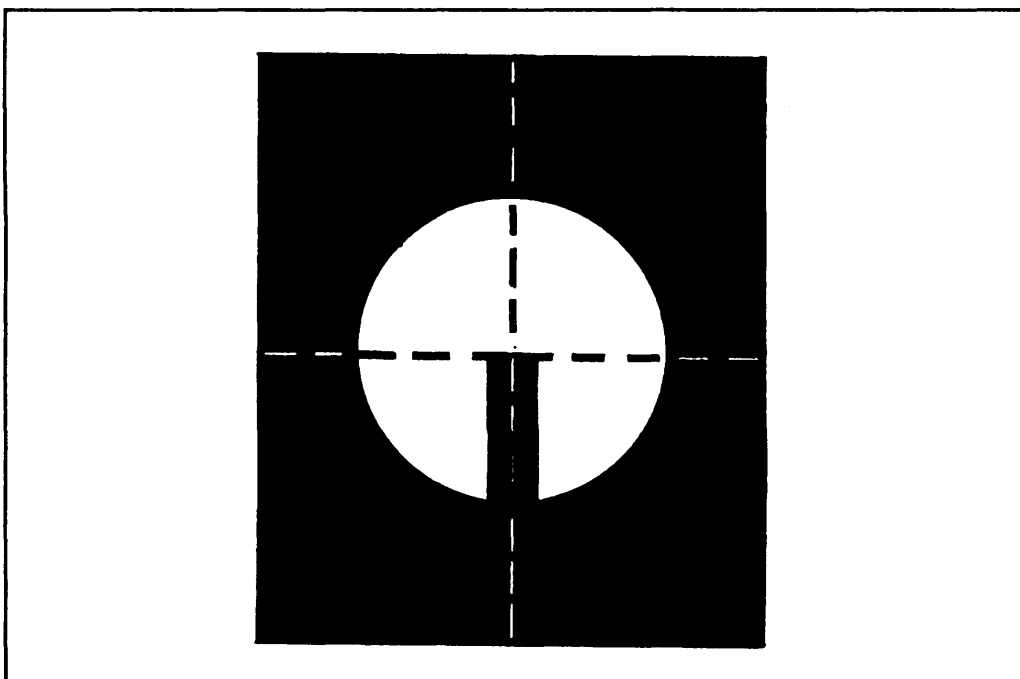

Figure 5-6. Correct sight alignment.

(3) The third step is to establish correct sight picture. To perform this task, the gunner adjusts the weapon until the top center of the front sight blade is bottom center of the intended target. Correct sight picture is a combination of sight alignment and placement of point of aim (Figure 5-7).

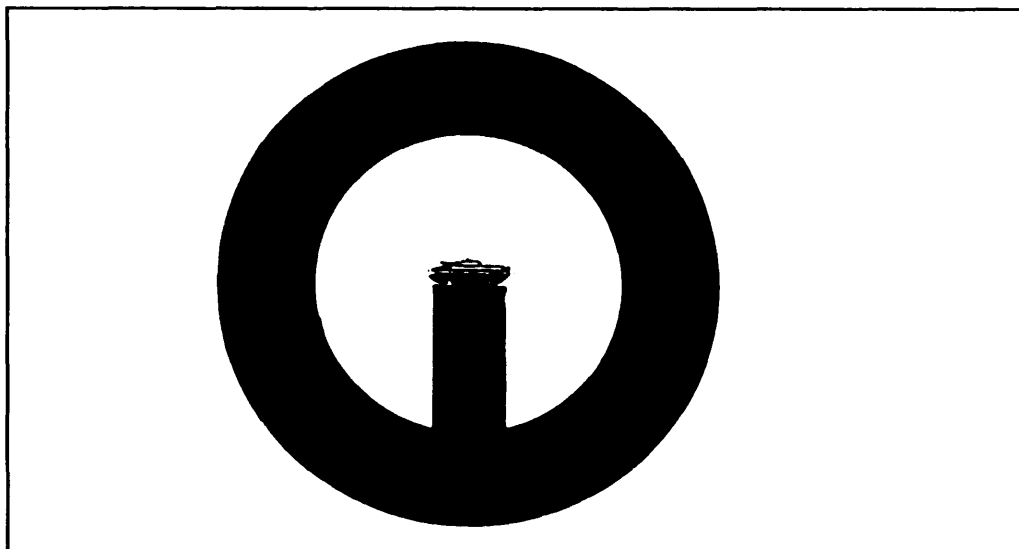

Figure 5-7. Correct sight picture.

b. **Range Setting and Laying.** Range setting and laying the gun are important elements in marksmanship training. It is this training that prepares the gunner to accurately and rapidly place fire on his target in combat. To properly set ranges, the gunner must be trained in rear sight operation.

(1) Setting ranges on the rear sight is a simple but important task. The gunner just has to rotate the elevating screw knob in a clockwise manner to move the peep sight up or counterclockwise to move it down. The range scale on the left is graduated in mils and the scale on the right in yards. The gunner must align the hairline index of the peep sight with the scale index line at the desired range as quickly and accurately as possible.

(2) Laying is placing the barrel of the weapon on a direct line with the target, using the sights. This must also be done as quickly and accurately as possible.

(3) The range setting and laying exercises are designed to require the gunner to practice and the instructor to evaluate both correct sight alignments and correct placements of aiming points. The exercise starts with the gunner in the sitting firing position with rear sight down. The coach will announce a range and general aiming point. The gunner will then repeat the range and direction of target. The coach will then announce, "Begin." The gunner will then raise and set his sights, and align the weapon on the aim point. When the gunner completes this task, he will announce "Up." The coach will then get behind the weapon and check the range setting and aim point and critique the gunner on his findings. This exercise will be continued until speed and accuracy is obtained.

c. **Traversing and Elevating Mechanism.** Manipulation of the T&E mechanism (Figure 5-8) is another key factor in effectively engaging targets. The gunner is taught how to instinctively manipulate the T&E mechanism to shift from one target to another. The gunners are trained to use the traversing handwheel, the traversing slide lock, and the elevating handwheel.

(1) The traversing mechanism consists of a traversing handwheel, locking nut, scale, and yoke. The T&E mechanism is attached to the traversing bar of the M3 bipod.

(a) The traversing bar is graduated in 5-mil increments and fits between the trail legs of the M3 tripod. The traversing slide and screw assembly are clamped in place on the traversing bar by the traversing slide lock lever. When the traversing slide is locked to the traversing bar, the traversing handwheel should be centered. The traversing slide is properly mounted when the lock lever is to the rear and the traversing handwheel is positioned to the left.

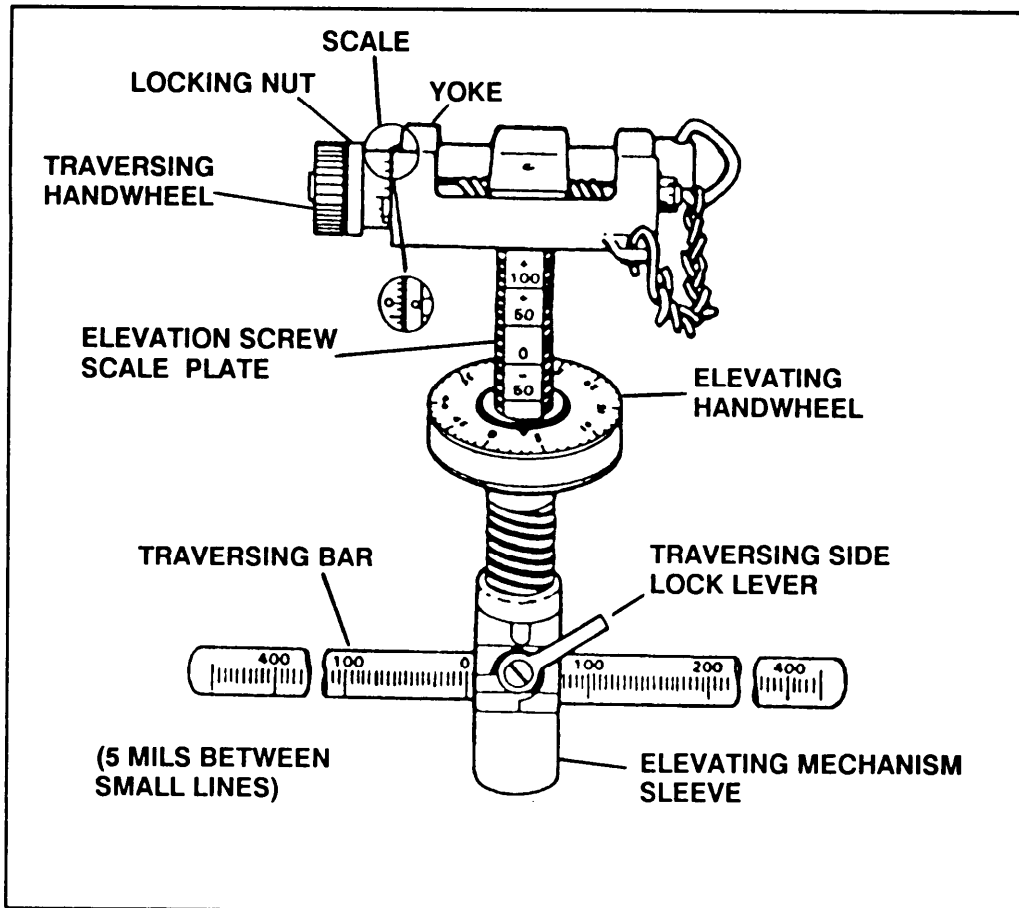

Figure 5-8. Traversing and elevating mechanism.

(b) To make changes in direction, loosen the traversing slide lock lever and move the slide along the traversing bar. This permits traverse of 400 mils left or right of the zero index in the center of the traversing bar. Readings on the traversing bar are taken from the left side of the traversing slide. For changes of 50 mils or less in deflection, turn the traversing handwheel. This allows a traverse of 50 mils left or right of center. One click in the traversing handwheel signifies 1 mil change in direction.

(2) The elevating mechanism consists of an upper and lower elevating screw, which is connected to the gun by inserting the quick release pin assembly through the holes in the upper elevating screw yoke and the rear mounting lugs of the receiver. A scale, graduated in mils, is fitted to the upper screw to indicate elevation. This scale is marked to show (-) minus 250 mils in depression and (+) plus 100 mils in elevation from the zero setting.

(3) The elevating handwheel is graduated in 1 mil increments from 0 to 50 mils and is fastened to the elevating screw by a screw lock. This synchronizes the handwheel graduations with those on the upper elevating screw. A spring-actuated index device produces a clicking sound when the handwheel is turned. Each click equals 1 mil change in elevation. The handwheel is turned clockwise to depress the barrel and counterclockwise to elevate.

(4) Direction and elevation readings constitute the data necessary to engage preselected target areas during limited visibility. These readings are measured by and recorded from the traversing bar and the T&E mechanism. To obtain accurate readings, the T&E must be first zeroed with all measurements recorded in mils.

(a) To zero the traversing handwheel, the gunner must first hold the T&E so that the traversing handwheel is on his left as he looks at it. He then turns the handwheel toward himself until it stops, loosens the locking nut slightly, and aligns the zero on the scale with the zero on the elevating screw yoke. Once the zeros are aligned, he tightens the locking nut. He must then turn the handwheel two complete turns away from the body and stop. The scale should again be on the zero. If this procedure is done at night, the gunner will turn 50 clicks away from him.

(b) To zero the elevating handwheel, the gunner must first turn the handwheel up or down until the handwheel is level with the line directly under the zero on the elevating screw plate scale, and the elevating handwheel indicator is pointing to the zero on the top of the handwheel. The elevating mechanism sleeve is then rotated up until it is stopped by the handwheel. The gunner then rotates the sleeve down until it stops, making sure he counted each complete rotation. He then divides the number of rotations by two, rotates the sleeve back up that number, and stops. The T&E mechanism is now ready to be attached to the tripod.

(c) To obtain and record direction readings, the gunner sets the sight on the proper range to hit the target, loosens the traversing slide lock lever, and slides the T&E mechanism along the traversing bar until the weapon is sighted on the aiming point of the target. The T&E mechanism is then locked down by tightening the traversing slide lock lever. All readings are taken from the left side of the sleeve mechanism. If the left side of the sleeve is not exactly on one of the 5-mil tick marks, the gunner must slide the sleeve to the next smaller tick mark to align it exactly. The traversing handwheel is then used to move the weapon back on point of aim. The direction is now ready to be recorded. The reading is taken from the number on the traversing bar and the direction from the direction of the barrel of the weapon. If the sleeve mechanism is on the right side of

the zero on the traversing bar, then the reading is left; if it is on the left side of the zero, then it is a right reading. The width of a target may also be measured and recorded by first moving the traversing handwheel until the sights are aligned with the right or left side of the target. The clicks required to do this measure the width.

NOTE: Before repositioning the weapon for another target, the gunner must realign the handwheel.

(d) To obtain an elevation reading, the gunner must first ensure that the sights are aligned and at the desired aim point of the target. The elevation reading is made up of two portions, a major reading and a minor reading. The major reading is taken from the elevating screw plate scale. The scale is graduated in 50-mil increments and ranges from a minus (-) 250 mils to a plus (+) 100 mils with a zero between them. There is an index line below each number and a plus or minus sign above each number, with the exception of the zero. The zero does not have a plus or minus sign. To obtain the elevation reading, the gunner should lower his head until his eyes are level with the elevating handwheel. The major reading is the first number with a plus or minus sign, with its index line just visible above the elevating handwheel. The minor reading is taken from the top surface of the elevating handwheel. It is graduated in 1-mil increments for a total of 50 mils. The handwheel is also equipped with an indicator that points to each number on the handwheel as it is turned. Once the gunner has the major reading from the screw plate scale, he will then get the minor reading by looking at the number at which the indicator is pointing. Both portions of the elevation reading are recorded by placing a slash (/) mark between the two portions.

(e) An elevation reading is valid only on one T&E mechanism. If the same data is placed on another T&E mechanism using the same weapon, the data may be inaccurate. The number of threads exposed on the T&E must remain the same both when obtaining and recording data. If the number of exposed threads is changed in any manner, the firing will be off target. For example, when a gun is freed to engage targets in the secondary sector, the data will be correct if the gunner ensures that the same amount of threads is exposed when he returns to his primary sector of fire.

(f) To ensure that the data is correct, the gunner should fire and adjust his weapon.

(5) The T&E manipulation exercise gives the gunner practice and the instructor a tool to evaluate the gunner's progress (Figure 5-9, page 5-12). The exercise is conducted in two stages. Both stages require the coach to give directions and the gunner to respond. In the first stage, the coach

positions himself about 10 paces to the front of the gun. He then directs the gunner to manipulate the weapon in certain directions. He indicates the direction by the use of hand signals. The gunner responds by manipulating the T&E mechanism with his left hand. The gunner must keep his eyes on the coach; at no time during this exercise is he permitted to look at the T&E mechanism. The coach must be very attentive during the first stage because the gunner will be manipulating using the elevating handwheel and the traversing handwheel. The second stage is done in the same way except the gunner must make bold changes in elevation and deflection. The exercise continues until the instructor is satisfied that the gunner can manipulate the weapon by T&E without looking at the device. This exercise can also be conducted using the basic MG target. The gunner will be shifted from one selected target to another. The coach must observe all movements of the gunner during this training.

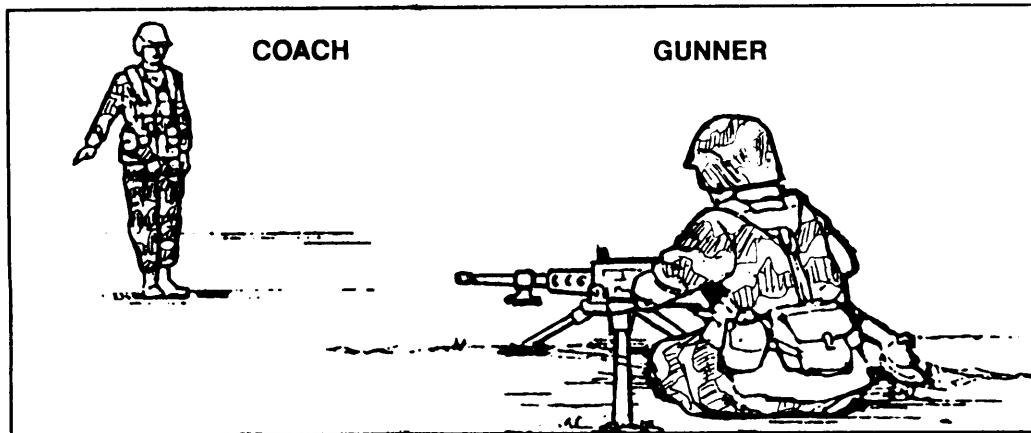

Figure 5-9. Manipulation exercise.

5-8. RANGE DETERMINATION

Range determination is the process of estimating the distance to a target from a gunner's position. The ability of the gunner to get the range to, sight on, and destroy a target is the realism of combat. Under combat conditions, ranges are seldom known in advance; therefore the effectiveness of fire depends largely upon the accuracy and speed of the gunner in determining range. Some methods of determining range are estimating by eye (Table 5-1, page 5-15), firing the gun, measuring range from a map or aerial photograph, stepping off the distance, or securing information from other units. Ranges are determined to the nearest 100 meters for machine gun firing. In combat, the most commonly used methods are estimating by eye and firing the gun. There is also a method used for measuring lateral distance.

a. The two techniques of eye estimation are the 100-meter unit of measure method and the appearance of objects method.

(1) When using the 100-meter unit of measure method, the gunner must be able to visualize what 100 meters looks like on the ground. With this distance in mind, the gunner can mentally determine the number of 100-meter units between his position and the target. The accuracy of this method is limited to 500 meters or less, and it requires constant practice (Figure 5-10).

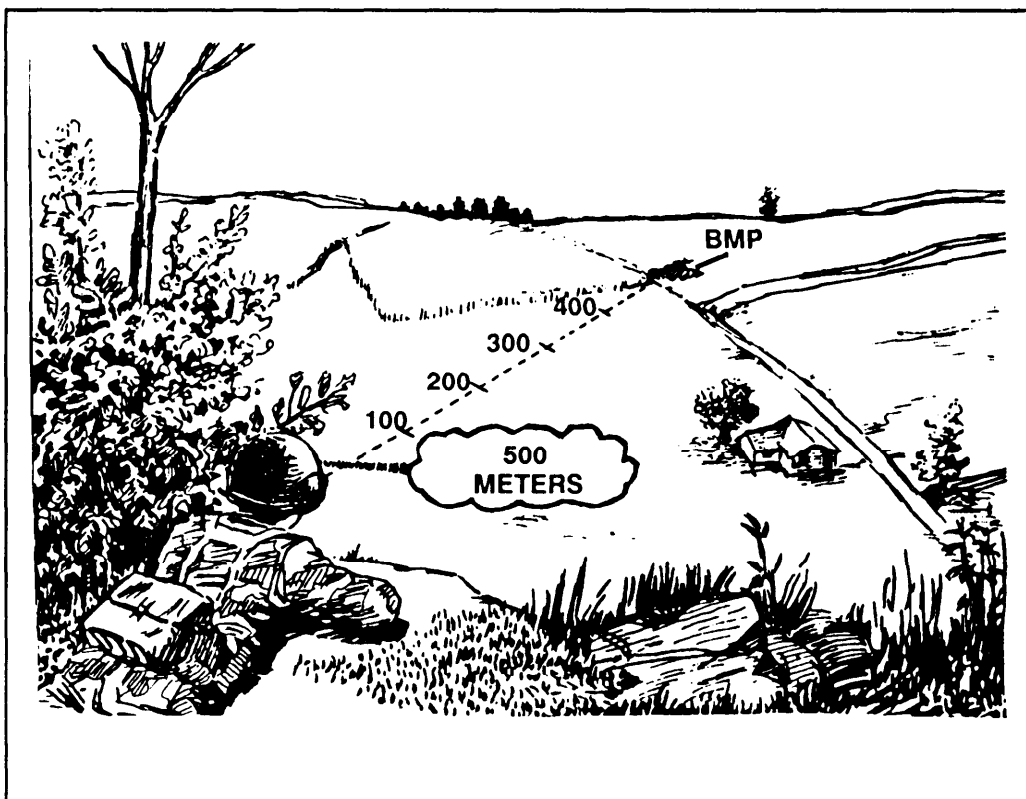

Figure 5-10. 100-meter unit of measure method, less than 500 meters.

(2) For targets that appear to be more than 500 meters, the gunner must modify this technique. The gunner selects what he thinks is the halfway point between the target and his position. He then mentally counts the number of 100-meter units to the halfway point and doubles it. This method of range determination is not accurate beyond 1,000 meters (Figure 5-11, page 5-14).

(3) Some terrain affects the appearance of 100-meter units of measure. When the terrain slopes upward toward the target, 100 meters appears longer than on level terrain. It appears shorter on downward

sloping terrain. The gunner must consider these two factors when using the 100-meter unit of measure method.

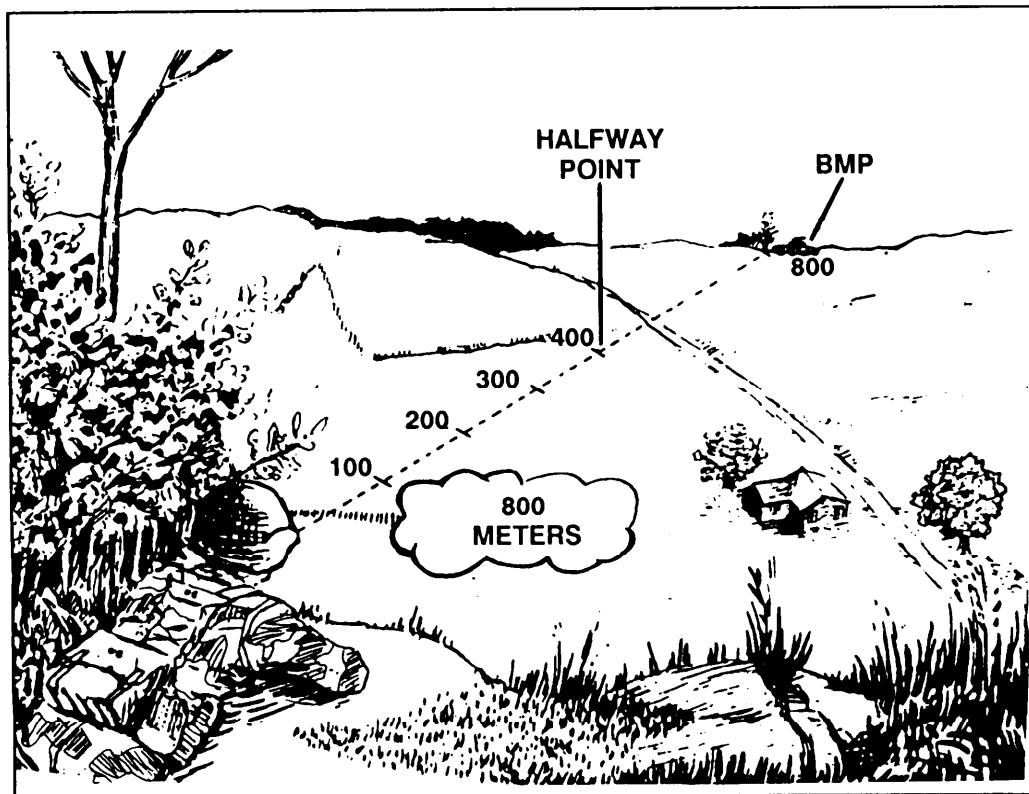

Figure 5-11. 100-meter unit of measure method, more than 500 meters.

(4) The appearance of objects method may be used if the gunner is unable to use the 100-meter unit of measure method because of terrain. To use this method, the gunner learns through practice how familiar objects look at various known ranges. This can be achieved by studying the appearance of a man standing 100 meters away. The gunner must then fix the appearance of the man firmly in his mind to include the size and details of his uniform and equipment. Next, he studies the same man at the same distance in the kneeling and prone positions. This procedure is used at 200, 300, 400, and 500 meters. By comparing the appearance of the man at these known ranges, he can establish a series of mental images that will help him determine range on unfamiliar terrain out to 500 meters. This training could also be conducted to familiarize the gunner with other objects, such as weapons and vehicles, at various ranges.

FACTOR	APPEARS NEARER (Range is underestimated when) –	APPEARS MORE DISTANT (Range is overestimated when) –
Target visibility.	Most of the target is visible and offers a clear outline.	Only a small part of the target is seen or target is small in relation to its surroundings.
Terrain, or position of the observer.	Looking across a depression, most of which is hidden from view. Looking down from high ground. Looking down a straight, open road or along a railroad track. Looking over uniform surfaces such as water, snow, desert, or grain fields.	Looking across a depression, all of which is visible. Looking from low toward high ground. When vision is narrowly confined as in streets, draws, or forest trails.
Light and atmosphere	In bright light or the sun is shining from behind the observer. The target is in sharp contrast with the background, or is silhouetted by reason of size, shape, or color, or is seen in the clear atmosphere of high altitudes.	In poor light such as dawn and dusk, in rain, snow, fog, or when the sun is in the observer's eyes. The target blends into the background or terrain.

Table 5-1. Factors affecting range estimation by eye.

b. Firing the gun is another method of determining range. In this method, the gunner opens fire on the target at the estimated range and moves the center of the beaten zone into the center base of the target by means of the T&E handwheels. He resets the sight so the new line of aim is at the center base of the target and notes the range setting on the rear sight. This range setting may apply only to this gun. When the ground in the vicinity of the target does not permit observation of the strike of the rounds, or when surprise fire on the target is desired, fire is adjusted on a point that offers observation and is known to be the same range as the target. The gunner then lays his gun on the target when ordered. When moving into position occupied by other units, range cards prepared by those units can furnish valuable range information on targets, suspected targets, and various terrain features. When the tactical situation and time permit, range may be determined by pacing off the distance.

c. Lateral distance measure is a method that the gunner may use to determine the distance from one target to another from left to right or right to left. When the gun is mounted on the M3 tripod, width can be measured by aiming on a point and manipulating the traversing handwheel, counting the clicks from one point to another point of aim. Each click equals one meter at 1,000 meters or one-half meter at 500 meters. This method is accurate but time-consuming. The finger

measurement method is not a method of range determination; it is a method of measuring the lateral distance (in fingers or mils) between two points. To measure the distance in fingers between a reference point and a target, extend the arm with palm outward, the fingers cupped, and elbow locked. Close one eye, raise the index finger, and sight along its edge, placing the edge of the finger along the flank of the target or reference point (Figure 5-12). The remaining space is then filled in by raising fingers until the space is covered. The measurement is then stated as being one or more fingers or so many mils, depending on the number of fingers used (Figure 5-13).

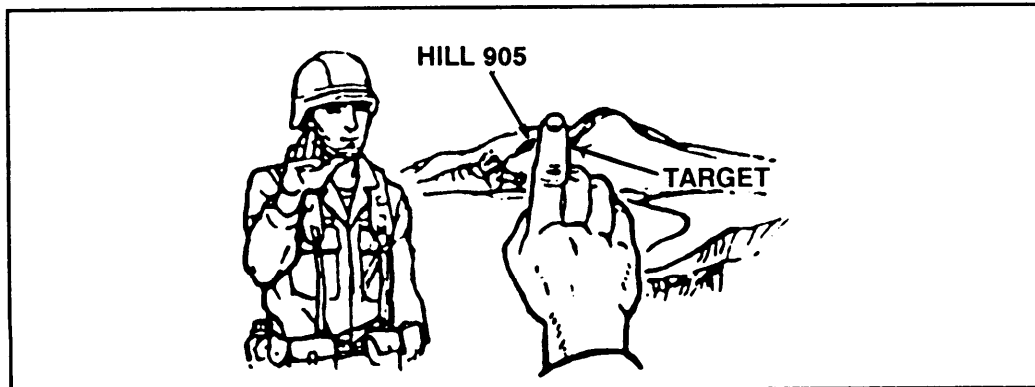

Figure 5-12. Index finger aligned.

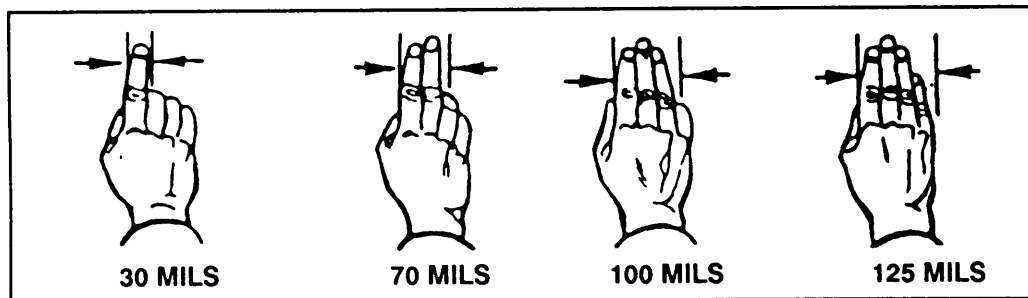

Figure 5-13. Mil/finger relationships.

5-9. OBSERVATION AND ADJUSTMENT OF FIRE

The purpose of observation and adjustment of fire practice is to teach the adjustment of fire by observing the strike of the bullets and the flight of the tracers, or by frequent re-laying on the target using sights.

a. Observation is used when firing on the 10-meter range because the impact of the round is visible on the target. When firing at greater distances, the strike of the round on the ground may cause dust to rise that is visible to the gunner; however, during wet weather, the strike cannot

always be seen. In this case, use tracer ammunition that allows the gunner or crew to note the strike of the burst in relation to the target.

b. Adjustments on the target can be made using the mil relation; that is, one click of traversing or elevating handwheel moves the strike of the round one-half inch on the target at 10 meters. When firing on field targets, adjustment is made by moving the burst into the target. One click of traverse will move the strike of the round one-half meter at 500 meters, or one meter at 1,000 meters (Figure 5-14). However, the distance one click of elevation will move the strike of the round depends on the range to the target and the slope of the ground. The gunner determines the number of mils necessary to move the center of the strike into the target, and he manipulates the gun the required number of mils. This does not require the use of sights. For example, should the gunner fire on a target at 500 meters and observe the strike 10 meters to the right of the target and short about 50 meters, he would traverse the gun to the left 20 clicks (mils) and add one or more clicks (mils), depending on the slope.

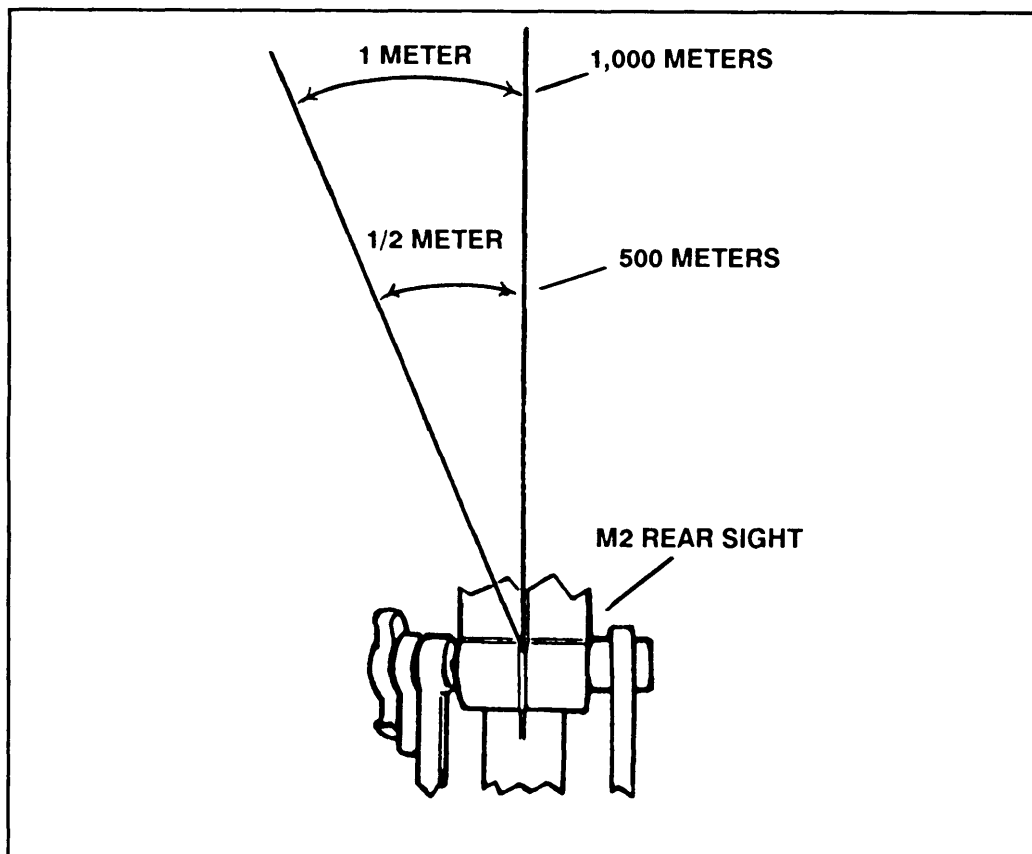

Figure 5-14. Mil relation.

c. The gunner may use the adjusted aiming point method to adjust the fire. In this method, the gunner must use his sights. He selects an aiming point that will place the next burst on target. For example, when the gunner fires on a target at 500 meters and estimates that the rounds impacted 20 meters short and 10 meters to the right, he would rapidly select an aiming point about 20 meters beyond the target and 10 meters to the left of it and lay on that aiming point and fire (Figure 5-15).

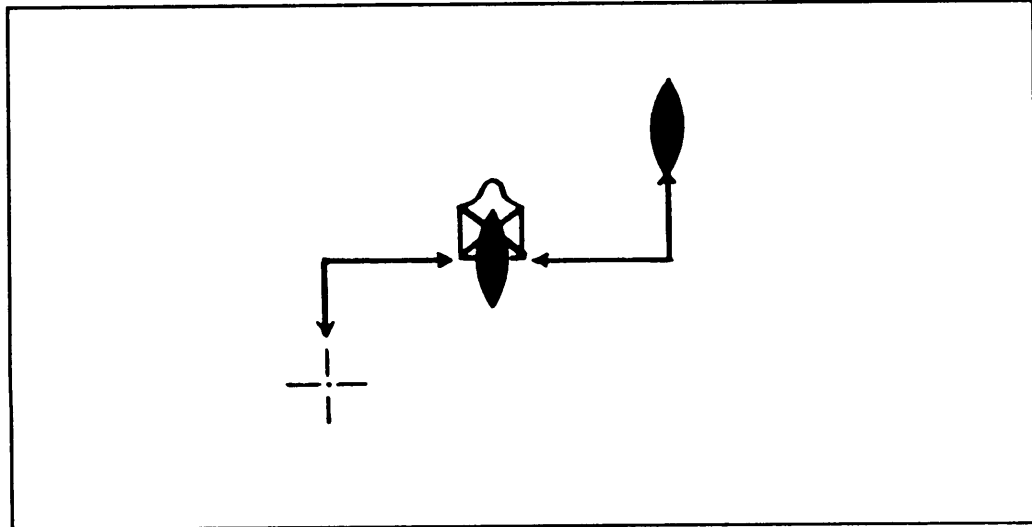

Figure 5-15. Adjusted aiming point method of fire adjustment.

5-10. FIRE COMMANDS

Fire commands are technical instructions issued by a leader to enable the unit or crew to accomplish a desired fire mission. Fire commands have been standardized for infantry direct fire weapons, and they follow the same sequence. There are two types – initial fire commands, issued to engage a target; and subsequent fire commands, which are issued to adjust fire, change the rate of fire, interrupt fire, shift fire to a new target, or to terminate the alert. A correct fire command is one that is as brief as clarity permits and yet includes all the elements necessary for the accomplishment of the fire mission. It is given in the proper sequence, transmitted clearly at a rate that permits receipt and application of instructions without confusion.

a. **Elements of the Initial Fire Command.** There are six essential elements of the initial fire command for the machine gun, which are given or implied by using one or more of the methods of control. During training, the gun crew repeats each element as it is given. This is done to avoid confusion and to train the crew to think and act in the proper

sequence. The six elements are the alert, direction, description, range, method of fire, and the command to open fire.

(1) *Alert.* This element brings the crew to a state of readiness to receive further instructions. Once alerted, the gunner ensures the gun is loaded. The assistant gunner continuously checks with the leader for orders or instructions and passes them on to the gunner. The oral alert is announced as FIRE MISSION. At this command, the gunners are alerted that a target has been detected and fire may be delivered upon it. When the leader announces the alert, such as FIRE MISSION, both gun crews react to the alert. If only a certain gun is to engage, the leader announces NUMBER 1 (or 2). The other crew follows the fire mission, loads, and lays on the target to take up the fire, if required.

(2) *Direction.* This element indicates the general direction to the target and may be given in one or a combination of the following ways:

(a) The leader gives the direction orally to the target in relation to the position of the gun(s). For example, FRONT, RIGHT FRONT, LEFT FRONT.

(b) The leader can designate a small or obscure target by pointing with his arm and hand or aiming the machine gun. When pointing with his arm and hand, a man standing behind him should be able to look over his shoulder and sight along his arm and index finger to locate the target. When a gun has been aimed at a target, a soldier looking through the sights should be able to see the target.

(c) Tracer ammunition is a quick and sure method of designating a target that is not clearly visible. When using this method, the leader should first give the general direction to direct the gun crew's attention to the desired area. To minimize the loss of surprise when using tracer ammunition, the leader does not fire until he has given all the elements of the fire command except the command to fire. The leader may use his individual weapon or fire one or more bursts from the machine gun. The firing of the tracer(s) then becomes the last element of the fire command and is the signal to open fire. For example:

FIRE MISSION.

FRONT.

BUNKER.

WATCH MY TRACER(S).

SLOW (or SINGLE SHOT).

The leader fires his individual weapon or a machine gun at the enemy bunker, then his gun crew(s) opens fire.

(d) Another method of designating obscure targets is by using easily recognizable reference points. Prominent terrain features and man-made

objects make good reference points. All leaders and members of the crew(s) must be familiar with the terrain features and the terminology used to describe them. The general direction to the reference point should be given. For example:

FIRE MISSION, NUMBER 2.
FRONT.
REFERENCE: LONE PINE TREE.
TARGET: TRUCK.

Sometimes a target must be designated by using successive reference points. For example:

FIRE MISSION, NUMBER 1.
RIGHT FRONT.
REFERENCE: RED-ROOFED HOUSE, LEFT TO HAYSTACK,
LEFT TO BARN.
TARGET: MACHINE GUN.

Finger measurements can be used to direct the gun crew's attention to the right or left of reference points. For example:

FIRE MISSION.
LEFT FRONT.
REFERENCE: CROSSROAD. RIGHT FOUR FINGERS.
TARGET: LINE OF TROOPS.

When the guns are mounted on tripods, lateral distance from reference points can be accurately announced. When gunners are firing the tripod-mounted gun, lateral distance is assumed to be in mils unless otherwise indicated, so the word "mils" is not necessary. For example:

FIRE MISSION.
FRONT.
REFERENCE: KNOCKED-OUT TANK. LEFT FOUR ZERO.
TARGET: COLUMN OF TROOPS.

(3) *Description.* The target description is used to create a picture of the target in the minds of the gun crew. The gun crew must know the type of target they are to engage to properly apply their fire. The leader should describe it briefly but accurately. For example:

Dismounted enemy personnel..... TROOPS
Automatic weapons..... MACHINE GUN
Armored vehicles TANK
Artillery or antitank weapon..... ANTITANK
Airplanes or helicopters..... AIRCRAFT

If the target is obvious, no description is necessary. Finger measurements or mil measurements can be used to designate the width of a linear target when the flanks cannot be pinpointed.

(4) *Range*. The range to the target is given so the gun crew knows how far to look for the target and immediately knows what range setting to place on the rear sight. Range is determined and announced in meters. Since the meter is the standard unit of range measurement, the word "meters" is not announced. With machine guns, the range is determined and announced in even hundreds and thousands. For example: THREE HUNDRED, ONE THOUSAND, ONE ONE HUNDRED. This element may be omitted when the gunners can obviously determine the range; however, it is desirable in some situations to announce the range.

(5) *Method of fire*. This element includes manipulation and rate of fire.

(a) Manipulation is used to prescribe the class of fire with respect to the gun. It is announced FIXED, TRAVERSE, SEARCH, TRAVERSE AND SEARCH, SWINGING TRAVERSE, or FREE GUN.

(b) To control the rate of fire, the gunner may use single shot, slow, rapid, or cyclic.

- Single shot. Place the gun in the single-shot mode and engage the target with aimed shots. The MG is accurate out to 1,500 meters.
- Slow fire. Slow fire consists of less than 40 rounds per minute, in bursts of five to seven rounds, fired at 10- to 15-second intervals.
- Rapid fire. Rapid fire consists of more than 40 rounds per minute, fired in bursts of five to seven rounds, at 5- to 10-second intervals.
- Cyclic fire. Cyclic fire is when the weapon fires 450 to 550 rounds per minute.

(6) *Command to open fire*. If surprise fire is not desired, the command FIRE is given without pause. It is often important that machine gun fire be withheld for maximum effect of surprise fire. To ensure this, the leader may preface the command to commence firing with the words AT MY COMMAND or AT MY SIGNAL. When the gunner(s) is ready to engage the target, he reports UP to the assistant gunner(s) who signals READY to the leader. For example:

FIRE MISSION.

FRONT.

TROOPS.

AT MY COMMAND. (Pause until crew members are ready and fire is desired.)

FIRE (or appropriate arm-and-hand signal).

When the leader makes a mistake in the initial fire command, he corrects it by announcing CORRECTION, and then gives the corrected element(s). For example:

FIRE MISSION.
FRONT.
TROOPS.
FIVE HUNDRED.
CORRECTION.
SIX HUNDRED.
TRAVERSE.
AT MY COMMAND.

When the leader makes an error in the subsequent fire command, he may correct it by announcing CORRECTION, and then repeating the entire subsequent fire command. For example:

LEFT FIVE, DROP ONE.
CORRECTION
LEFT FIVE, DROP ONE ZERO.

b. **Subsequent Fire Commands.** If the gunner fails to adjust his fire on the target, the leader must promptly correct him by announcing or signaling the desired changes. When changes are given, the gunner makes the required corrections and continues to engage the target without further command. When firing under the control of a leader, the assistant gunner checks with the leader for instructions, which he passes on to the gunner. Changes in the rate of fire are given orally and by arm-and-hand signals. To interrupt firing, the leader announces CEASE FIRE or gives a signal to cease fire. The gun crew(s) remains on the alert and firing can be resumed on the same target by announcing FIRE. To terminate the alert, the leader announces CEASE FIRE, END OF MISSION.

5-11. CREW EXERCISES

The purpose of crew exercise is to develop precision, speed, skill, and teamwork in examining equipment, placing the gun into action, and taking it out of action. In crew exercise, precision must be stressed. Once that is attained, speed, skill, and teamwork will follow. Duties are rotated during crew exercise to allow each member of the gun crew to become familiar with all the duties. During crew exercise, all oral or visual signals are repeated. When the fire command is completed, the gunner will give the assistant gunner an UP. The assistant gunner will extend his hand and arm into the air in the direction of the leader (to indicate READY) and announce, UP. With the M3 mount, the crew must consist of at least four men, including the leader. There is no designated crew in the TOE for a

dismounted caliber .50 MG. The following paragraphs are only suggestions for the breakdown of equipment and member designation that may be established by the commander.

a. **Crew Equipment.** In addition to individual arms and equipment, crew members carry the following equipment for the tripod-mounted machine gun:

<u>CREW MEMBER</u>	<u>SUGGESTED MINIMUM EQUIPMENT</u>
Squad or crew leader.	Binoculars, compass, one box of ammunition.
No. 1 Assistant gunner.	Tripod.
No. 2 Gunner.	Receiver, T&E mechanism attached, and headspace and timing gauge.
No. 3 Ammunition bearer.	Barrel, barrel cover, and box of ammunition.

b. **Form for Crew Exercise.** The crew leader commands, FORM FOR CREW DRILL.

(1) *Positions with equipment.* The crew forms in column, facing the crew leader with five paces between men (Figure 5-16, page 5-24). They are in the following order: assistant gunner, gunner, and ammunition bearer. When the crew members reach their correct positions, they assume the prone position with equipment arranged as follows:

(a) No. 1: Tripod to his left, trail legs to the rear, front leg uppermost.

(b) No. 2: Receiver across his front, backplate to the right, retracting slide handle uppermost.

(c) No. 3: Barrel to his right, muzzle to the rear, ammunition box to his left front with latch to the right (latch to the front for the new box).

(d) Other members, if present: Ammunition boxes in front, one foot apart, latches to the right (front).

(e) Crew leader: Ammunition box to his right as he faces the crew, latch to the right (front).

(2) *Rotation of duties.* Duties are rotated to ensure that each member learns and is capable of performing the duties of the other members.

(a) The command to rotate all personnel is, FALL OUT LEADER. At this command, each member of the crew rises, moves forward, and assumes a new duty. The crew leader becomes the ammunition bearer. The assistant gunner moves forward and becomes the crew leader. The gunner moves forward and becomes the assistant gunner. The ammunition bearer moves forward and becomes the gunner.

(b) If the leader is not changed, the command, FALL OUT ASSISTANT GUNNER, is given. At this command, the crew members rise, the gunner becomes the assistant gunner, the ammunition bearer becomes the gunner, and the assistant gunner becomes the ammunition bearer. When the crew members have assumed their new position, they call out their new duties in order, ASSISTANT GUNNER, GUNNER, AMMUNITION BEARER.

NOTE: An additional crew exercise, which the crew maybe required to practice, is the setting of headspace and timing. These procedures are outlined in paragraph 3-6.

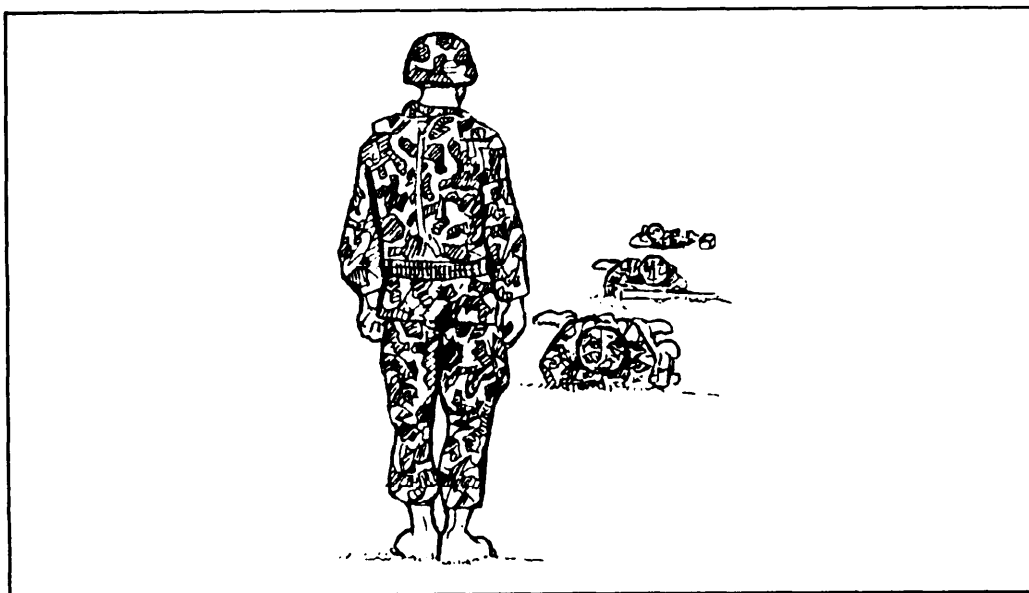

Figure 5-16. Crew formed in column.

c. Inspection of Equipment Before Firing. When the crew is formed with equipment, the command is, INSPECT EQUIPMENT BEFORE FIRING. At this command, the crew proceeds as follows:

- (1) The assistant gunner inspects the tripod M3 mount to ensure that:
 - (a) The indexing levers and clamps on the front and trail legs function properly, and the legs are in the short (low) position.
 - (b) The front leg and trail legs are closely folded, and the front leg clamp is hand tight.
 - (c) The sleeve lock latch and pintle lock release cam are in working order, and the pintle lock release cam is down.
 - (d) The pintle bushing is free from dirt and burrs.
- (2) The gunner inspects the receiver group to ensure that:

-
- (a) The barrel support and breech bearing are free of dirt.
 - (b) The gun pintle is free of dirt.
 - (c) The feed mechanism and bolt switch are properly assembled to feed from left (soldier raises cover for proper inspection).
 - (d) The striker projects through the aperture in the face of bolt (soldier closes the cover).
 - (e) The rear sight is set at 1,000 yards (900 meters) windage zero.
 - (f) The T&E mechanism is securely attached to the receiver.
 - (g) The traversing handwheel is centered.
 - (h) The elevating screws are equally exposed (about 2 inches) above and below elevating handwheel.
 - (i) The backplate is latched and locked in place.
 - (j) The bolt latch release is locked in the down position by the bolt latch release lock.
- (3) The ammunition bearer inspects the barrel and ammunition box to ensure that:
- (a) The barrel is clear.
 - (b) The barrel carrier assembly is securely attached to the barrel.
 - (c) The barrel threads are free of dirt.
 - (d) The metallic links are clean (soldier opens ammunition box).
 - (e) The belt is properly loaded and placed in box with the double-looped end up.
 - (f) Dummy ammunition is used during crew exercise, and no live ammunition is present.
 - (g) The box is closed and latched.
- (4) When the ammunition bearer completes his inspection, he moves to the gunner's position with the barrel in his right hand and ammunition box in his left hand. With the aid of the gunner, he screws the barrel into the barrel extension (Figure 5-17, page 5-26). The headspace and timing adjustment is made. The ammunition bearer remains on the left and on line with the gunner.
- (5) The crew leader examines his ammunition as described in paragraph (3).
- (6) At the completion of the inspection, a report is rendered as follows:
- (a) The ammunition bearer reports: AMMUNITION CORRECT (or any deficiencies).
 - (b) The gunner reports: GUN AND AMMUNITION CORRECT (or any deficiencies).
 - (c) The assistant gunner reports: ALL CORRECT (or any deficiencies).
-

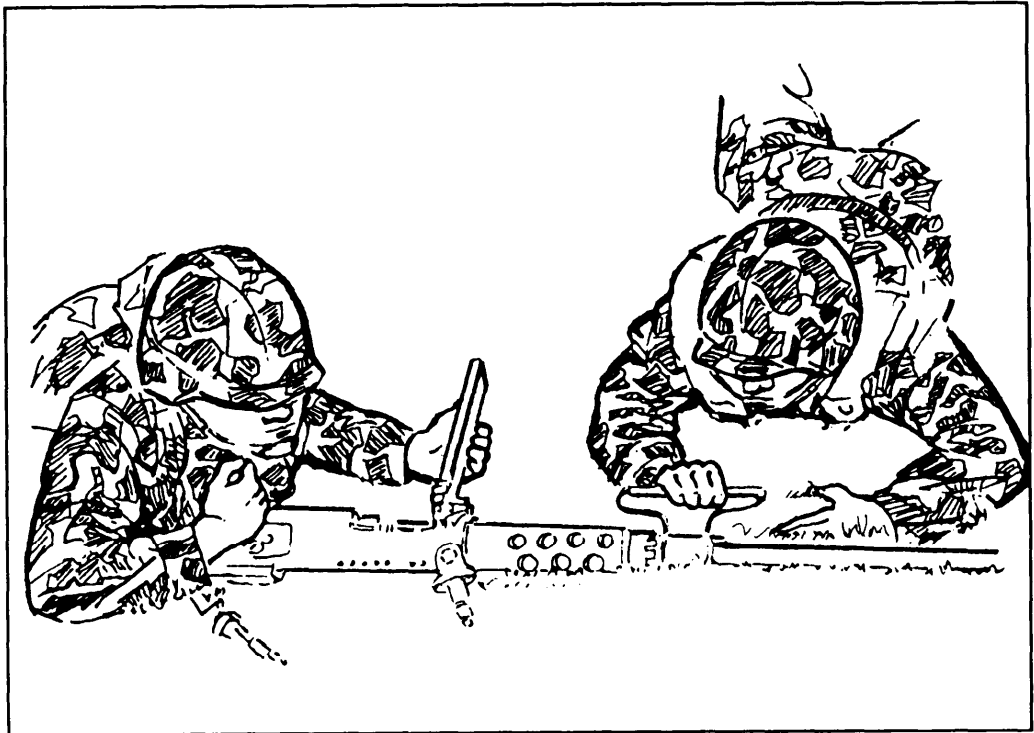

Figure 5-17. Screwing the barrel into the barrel extension.

d. **Placement of the Gun Into Action.** To place the gun into action, the crew leader commands and signals, GUN TO BE MOUNTED HERE (pointing to the position where the gun is to be mounted), FRONT (pointing in the direction of fire), ACTION (vigorously pumping his fist in the direction of the designated gun position).

(1) At the command or signal ACTION, the assistant gunner grasps the left trail leg near the center with his left hand. Springing to his feet and grasping the tripod head with his right hand, he lifts the tripod across the front of his body with the front leg up, and carries the tripod to the desired location. Upon arrival at the position, he places the trail leg pointing upward. Steadying the tripod with his left hand on the front leg, he loosens the front leg clamp with his right hand (Figure 5-18), positions the front leg with his left hand, and tightens the front leg clamp with his right hand. With his right hand on the tripod head, he slides his left hand down on the left trail leg and with a snapping motion, pulls the left leg (to the left), engaging the sleeve latch (Figure 5-19). He then aligns the tripod for direction, drops the mount to the ground, stamps the right and left trail shoes with his right or left foot, and assumes the prone position behind the mount.

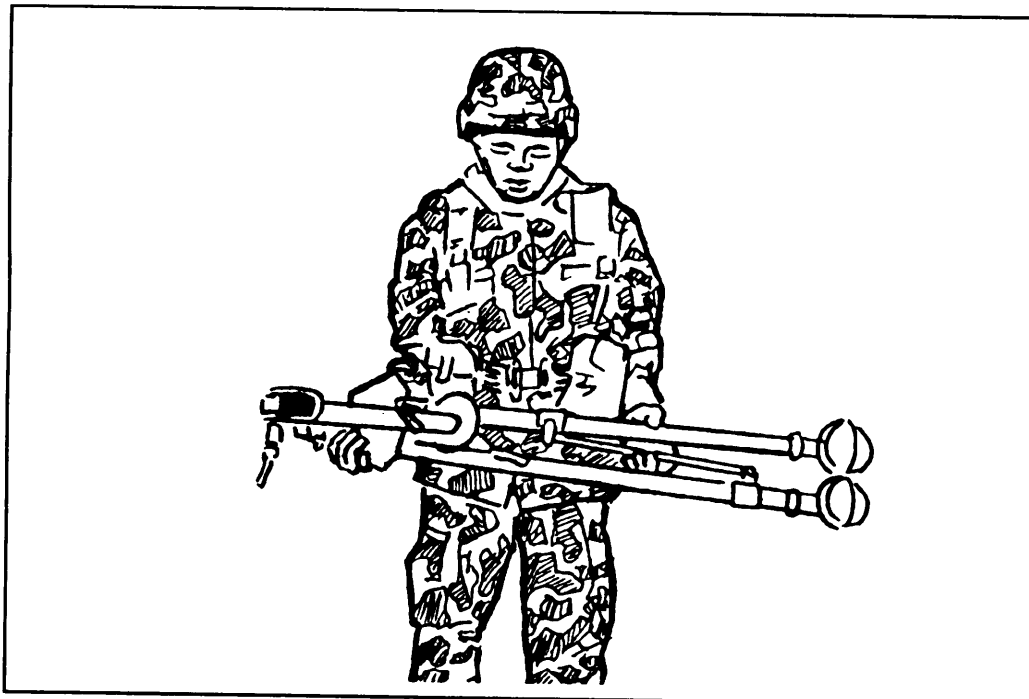

Figure 5-18. Assistant gunner-(No.1) opening the tripod.

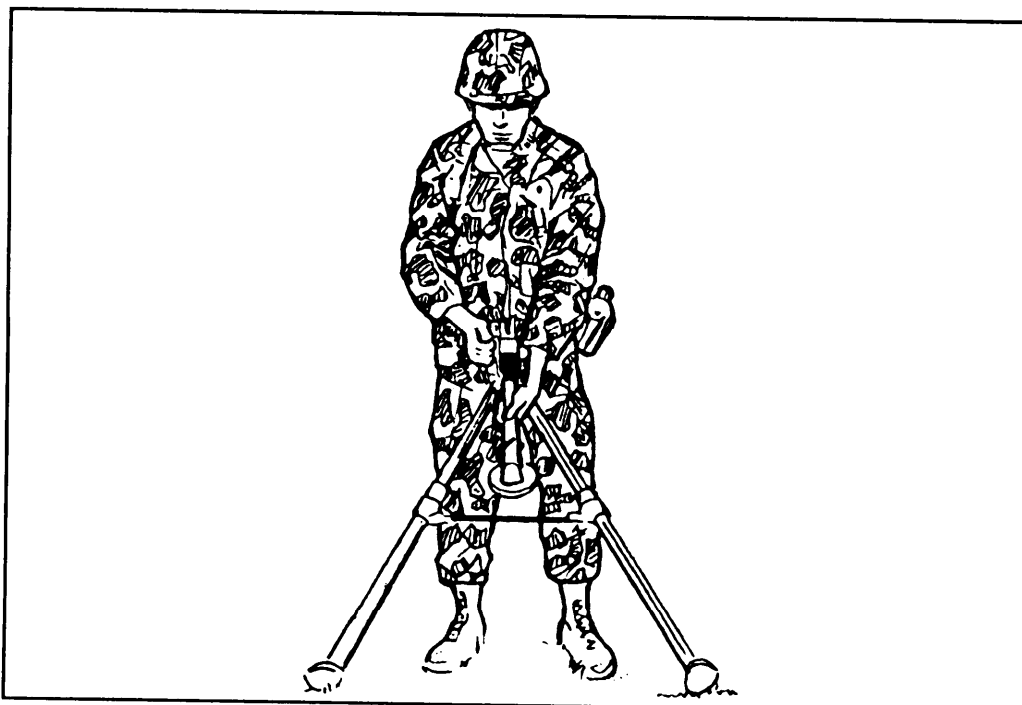

Figure 5-19. Emplacing the mount.

(2) The gunner and ammunition bearer move together. When the tripod is nearly mounted, the gunner and ammunition bearer spring to their feet. The gunner places both hands on the spade grips, the ammunition bearer grasp the ammunition box in his left hand and the gun carrying handle with this right hand. Both men lift the gun from the ground and move rapidly to the gun position. Then the ammunition bearer places the ammunition box on line and in front of the leader's ammunition box. The gunner, assisted by the ammunition bearer, inserts the pintle into the pintle bushing. The ammunition bearer stamps the front shoe into the ground with his left foot (Figure 5-20), releases the carrying handle, lowers his right hand, and lifts the gun pintle lock release cam. When the gun pintle is fully seated, he presses down the pintle lock release cam with his right hand, turns to his left, and returns to his original position.

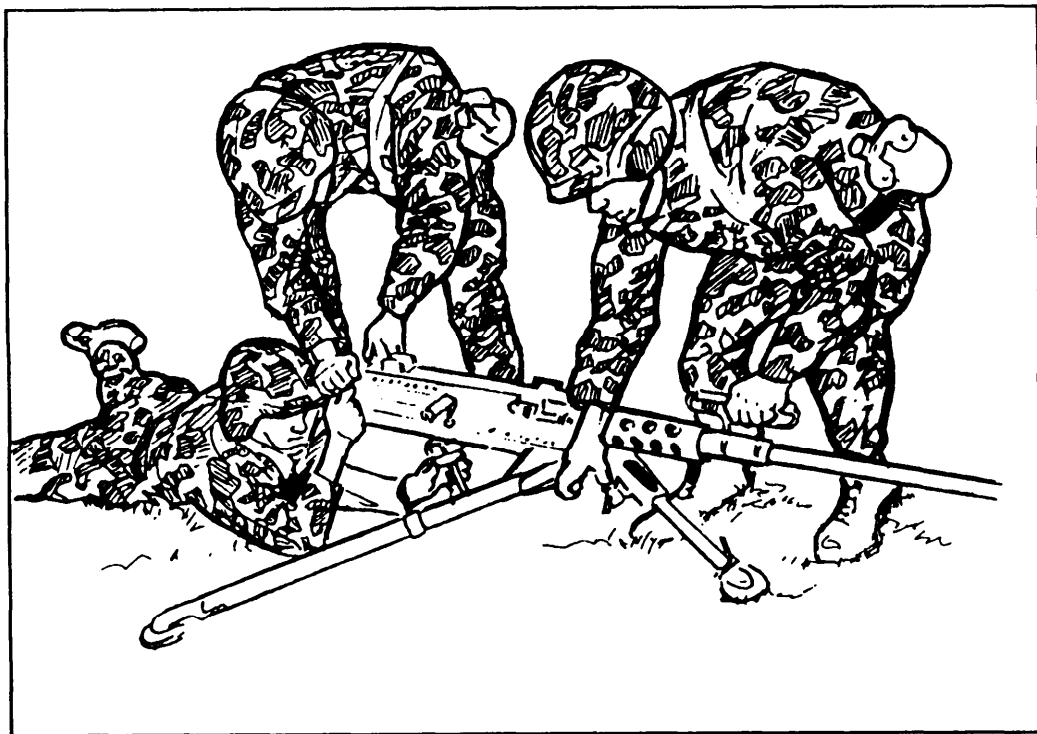

Figure 5-20. Mounting the gun.

(3) The assistant gunner holds the left spade grip with his left hand. With his right hand, he lowers the T&E mechanism to the traversing bar, ensuring that the traversing handwheel is to the left and the lock lever is to the rear. He then assumes a semiprone position to the left of the gun with his feet to the rear and his head on line with the feedway. He unlatches and raises the cover of the ammunition box, removes the ammunition belt,

inserts the double-looped end into the feedway, and taps the feedway with his right hand to ensure it is closed.

(4) With his right hand palm-up, the gunner grasps the retracting slide handle, vigorously jerks it to the rear, and releases it. The gun is half-loaded (Figure 5-21). He then assumes a prone position directly behind the gun with his legs spread and heels down. His right hand lightly grasps the right spade grip with the thumb in position to depress the trigger. His left hand is on the elevating handwheel (palm down) with his thumb near the traversing slide lock lever. He rests on his left elbow with his head as close as possible to the rear sight (Figure 5-22, page 5-30). He then gives the assistant gunner an UP. The assistant gunner announces UP and extends his hand and arm into the air in the direction of the leader.



Figure 5-21. Gun mounted, gunner half-loading the gun.

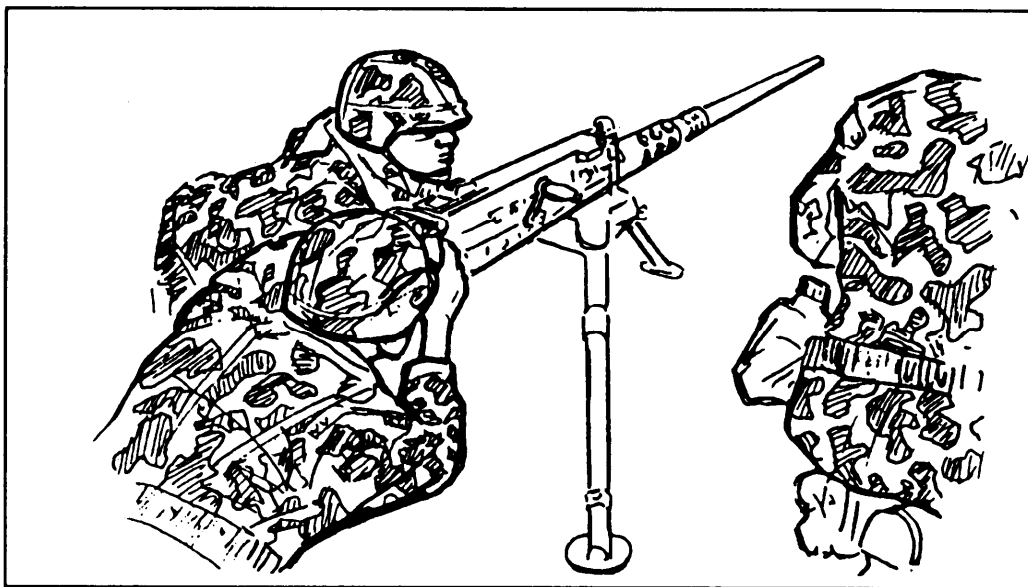

Figure 5-22. Crew ready for action.

e. **Removal of the Gun From Action.** To take the gun out of action, the command is OUT OF ACTION.

(1) The gunner raises the cover with his left hand, the assistant gunner lifts the ammunition out of the feedway, replaces the ammunition in the box, and closes and latches the box. The gunner closes the cover, pulls the retracting slide handle to the rear with right hand (palm up) and releases it, presses the trigger with his right thumb, and loosens the traversing slide lock with his left hand. He rises to his feet, grasping both spade grips. At this time, the ammunition bearer will arrive at the gun position. With his left hand, the ammunition bearer grasps the ammunition box and places his right foot on the front leg shoe. With his right hand, he reaches down and lifts up the pintle lock release cam and grasps the carrying handle (Figure 5-23).

(2) The gunner and ammunition bearer lift the gun from the tripod, turn right, and carry the gun back to their original position. They set the gun down with the muzzle to the left and the retracting slide handle up. The gunner pulls the retracting slide handle to the rear and aligns the lug on the barrel locking spring with the 3/8-inch hole in the right side of the receiver. The ammunition bearer unscrews the barrel from the receiver, picks up the ammunition box and barrel, moves five paces to the rear, places the barrel to his right with the muzzle to the rear and the ammunition box to his left, and assumes the prone position.

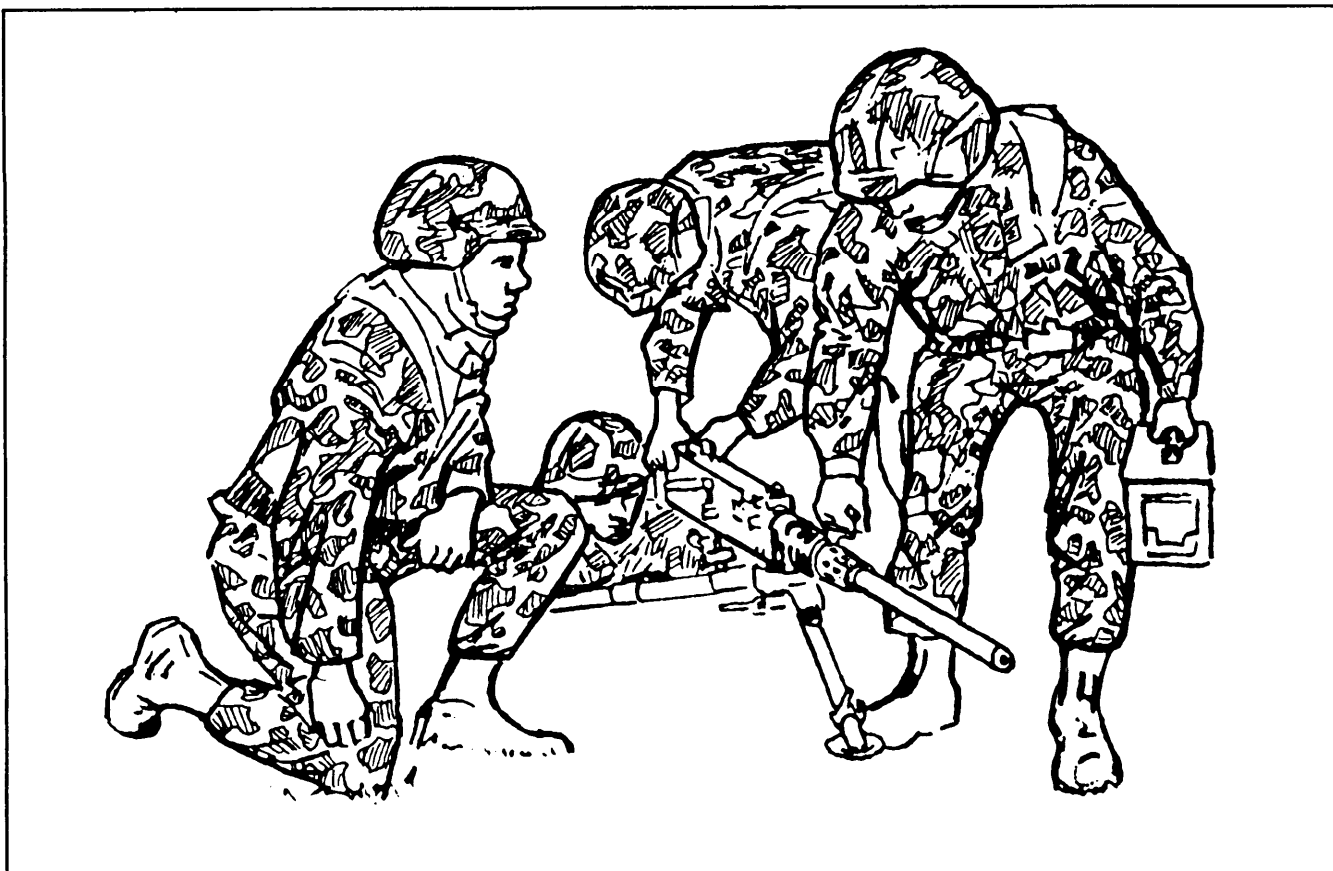

Figure 5-23. Crew taking the gun out of action.

(3) The gunner rotates the bolt latch release lock to the right and releases the bolt latch. He checks his sights to ensure they are properly set.

(4) The assistant gunner assumes a kneeling position behind the tripod and releases the sleeve lock latch with his right hand. He rises to his feet, grasps the front leg with his left hand, and rotates the tripod to a vertical position on the trail legs. With his right hand, he loosens the front leg clamp, folds down the front leg, then tightens the clamp. With his right hand on the tripod head, he rotates the tripod on the right trail leg and releases the sleeve latch. Then he folds the left trail leg against the right with his left hand (Figure 5-24, page 5-32). Holding the tripod head with his right hand, trail legs with his left, he lifts the tripod across the front of his body with the front leg up. He turns to the right and returns to his original position. At this time, the crew leader picks up his ammunition box and faces the crew. The assistant gunner places the tripod on the ground, assumes a prone position to the right of the tripod, and announces UP.



Figure 5-24. Folding the trail legs.

f. **Duties of The Crew.** To hand-carry the gun and equipment, the command is SECURE EQUIPMENT, FOLLOW ME. At this command,—

- (1) The crew leader carries his ammunition box in his right hand.
- (2) The assistant gunner carries the tripod over either shoulder.
- (3) The gunner carries the receiver on either shoulder with the spade grips to the front.
- (4) The ammunition bearer carries his ammunition box in his left hand and the barrel in his right hand with the muzzle to the rear (or on his left shoulder with the muzzle to the front).

g. **Relocation of Tripod-Mounted Gun.** When the gun is mounted on the tripod, it can be moved for short distances by dragging or by a two- or three-man carry. (In the latter, the men should move in step to make carrying easier.)

(1) *Dragging.* The gun is dragged when there is limited cover, or when the situation requires the gun to be moved in this manner. The gunner and assistant gunner drag the mounted gun to the desired position (Figure 5-25).

(2) *Two-man carry* With the gunner on the right and assistant gunner on the left, each grasps the front leg with his forward hand and a trail leg with the other hand, just above the traversing bar (Figure 5-26).

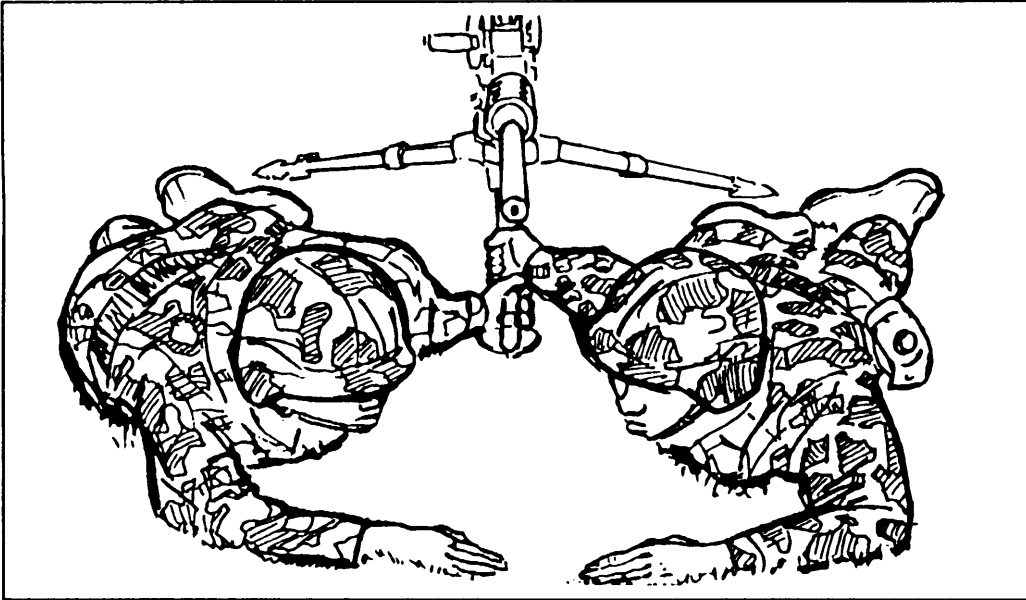

Figure 5-25. Dragging the gun into position.

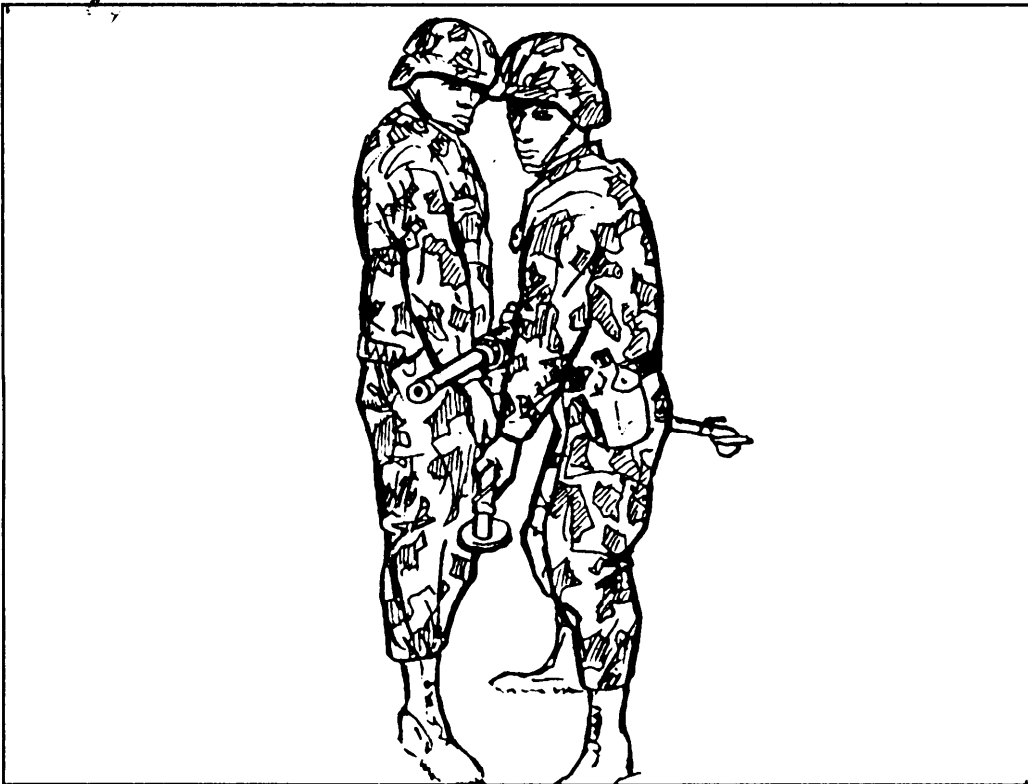

Figure 5-26. Two-man carry.

(3) *Three-man carry.* When the barrel is hot, the gunner gets behind the tripod with a trail leg in each hand. With the assistant gunner on the left and the ammunition bearer on the right, each grasps the carrying handle. In addition, the assistant gunner carries the ammunition in his left hand (Figure 5-27). When the barrel is cool, the ammunition bearer and the assistant gunner each grasp the front leg (Figure 5-28).

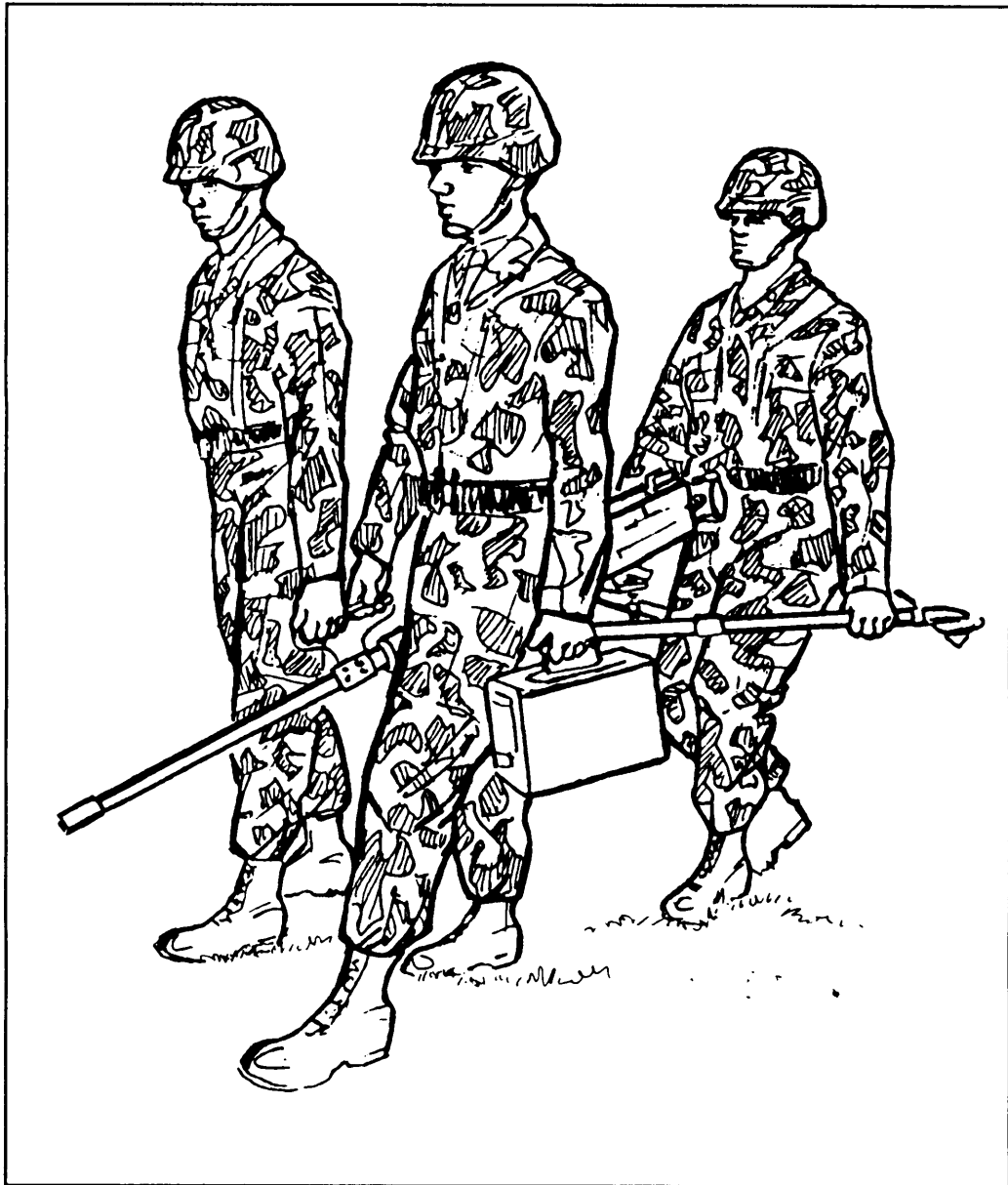

Figure 5-27. Three-man carry (hot barrel).

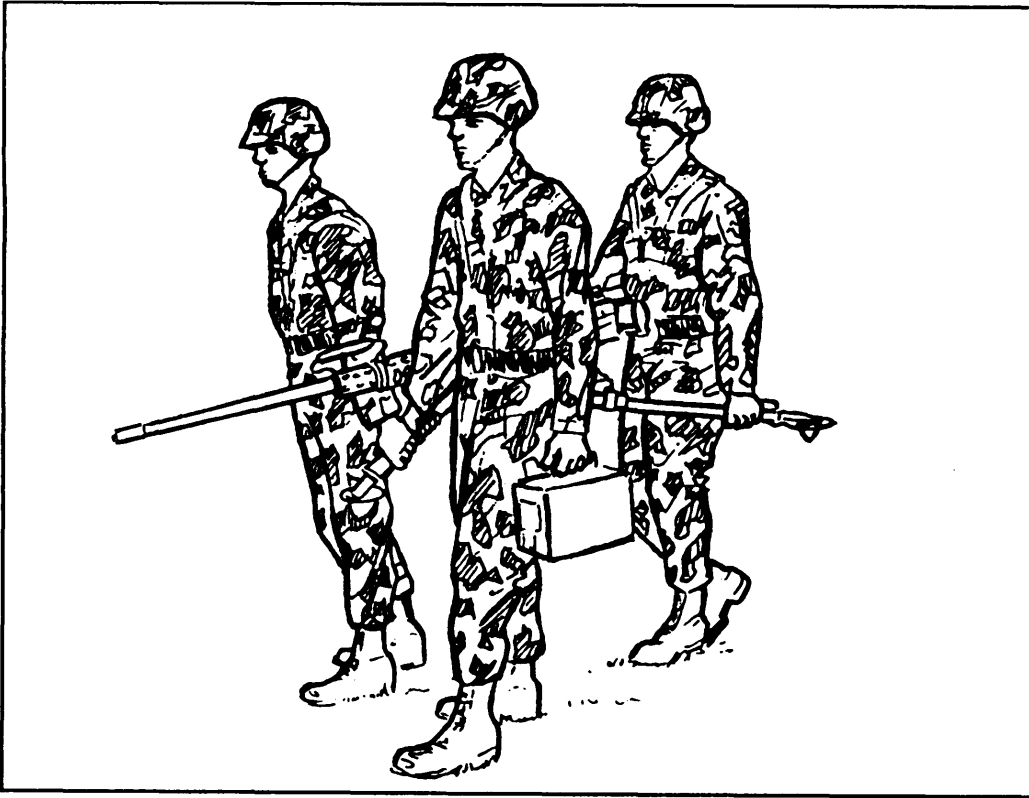

Figure 5-28. Three-man carry (cola barrel).

NOTE: Carrying the gun by the barrel may cause damage to the barrel support and the barrel extension.

h. Movement of the Gun to Other Mounts. With the mount prepared to receive the gun, the cradle of the mount is placed in a horizontal position. To move the gun to the mount, the gunner carries the right spade grip in his left hand and a box of ammunition in his right. The assistant gunner grasps the carrying handle with his left hand and a box of ammunition in his right hand. When they get to the mount, the gunner and assistant gunner place their ammunition boxes near the mount. The gunner removes the rear mounting (gun-locking) pin with his right hand. The assistant gunner removes the front mounting (gun-locking) pin with his right hand. They place the gun on the mount. The gunner aligns the holes in the rear mounting lugs of the receiver with the rear mounting bracket and inserts the rear mounting pin. The assistant gunner aligns the front mounting hole in the front of the receiver with the front mounting bracket and inserts the front mounting pin. (For use of the sideplate trigger with the M63 mount, see TM 9-1005-213-10.)

5-12. MACHINE GUN FUNDAMENTAL SKILLS TEST

The machine gun fundamental skills test should be held periodically to ensure that proficiency with the MG is maintained by all crewmen. It consists of 10 fundamental skills; all tasks are hands-on (Figure 5-29). The test should be given prior to range firing on a go/no-go basis.

TASK	GO/NO-GO	
1. Clear the MG.	✓	
2. Disassemble the MG.	✓	
3. Assemble the MG.	✓	
4. Do a function check.	✓	
5. Maintain the MG.	✓	
6. Set the headspace on the MG.	✓	
7. Set the timing on the MG.	✓	
8. Load the MG.	✓	
9. Perform immediate action on the MG.	✓	
10. Unload the MG.	✓	

Figure 5-29. The MG fundamental skills test.

Section III. BASIC MARKSMANSHIP

This phase of training is designed to allow the gunner to apply the fundamentals of marksmanship that he learned earlier. During this training, the gunner is introduced to the basic machine gun target (see Appendix C), procedures for both the 10-meter and field fire ranges, and how to acquire targets. He also fires practice and qualification.

5-13. CONCEPT OF ZEROING/TARGETING

The concept of zero is very simple; it is no more than the best way to adjust the sights of the weapon so the point of aim of the sights and the point of impact of the rounds are the same at any given range. A properly zeroed M2 gives the gunner the highest probability of hit for most combat targets with the least adjustment to the point of aim. There are three methods of zeroing/targeting used with the .50 caliber MG.

a. Ten-meter zero is the basic and the most common method of zeroing the M2 MG. Once zeroed on a 10-meter range using the standard machine gun target, the weapon is ready for field fire. As other weapons, the sight on the M2 must also be set at an initial start point (Figure 5-30). The initial sight setting for field zero is basically the same; except the range setting during field zero will depend on the range to the target, and it is always 1,000 yards for 10 meters.

(1) *Set elevation.* Raise the rear sight by lifting straight up until it snaps into the upright position. Adjust the range scale to 1,000 yards by rotating the elevation screw knob in the necessary direction. (Clockwise moves the scale up; counterclockwise moves the scale down.)

(2) *Set windage.* Rotate the windage knob until the zero index mark on the base rear sight is aligned with the index mark on the top of the receiver. (Clockwise moves the windage scale to the left; counterclockwise moves it to the right.)

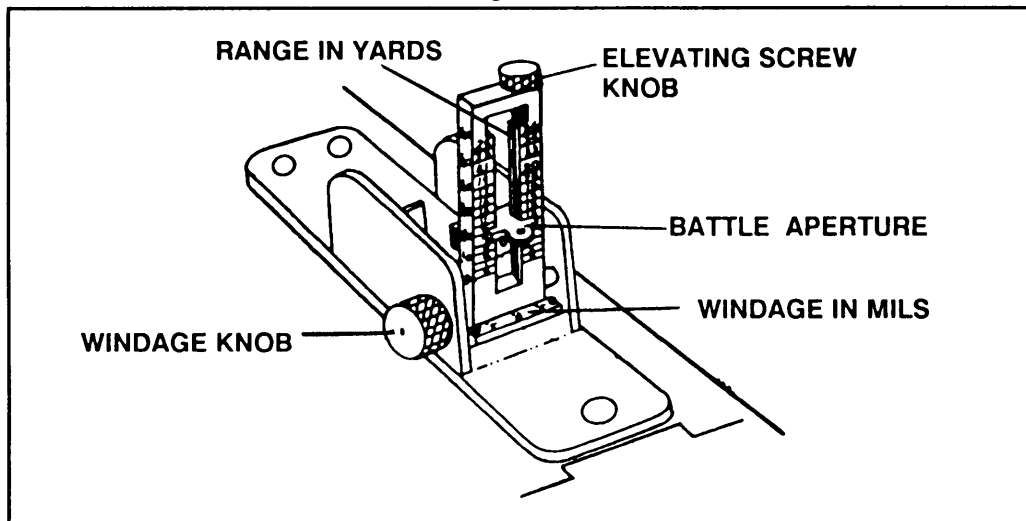

Figure 5-30. Rear sight setting.

(3) *Obtain proper sight picture.* Obtain the proper sight picture by looking through the zero aperture and centering the front sight blade in it. Once the sight alignment is obtained, place this combination on the center base of the selected target (Figure 5-31).

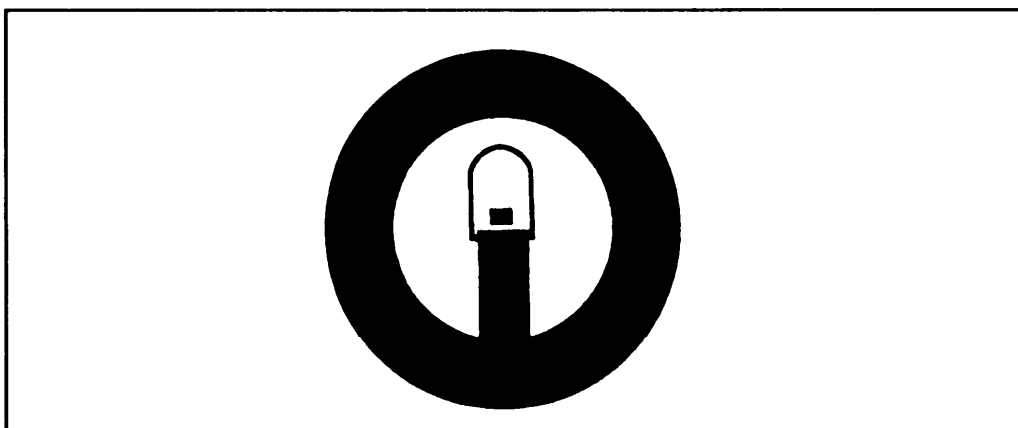

Figure 5-31. Proper sight picture.

b. Field zeroing/targeting is an expedient method of obtaining a zero when a 10-meter zero cannot be conducted. When preparing to field zero, make sure the M2 is mounted securely on the M3 tripod, make sure the T&E is working properly, and finally, know the distance to your zero target. The only difference in initial sight setting for field zero is range setting on the scale. The gunner must also remember that the range scale on the M2 is indicated in yards. Therefore, in order to get as close to the target as possible, you may have to convert the meters to the target into yards so you can set the range on the rear sight. Conversion of meters to yards is accomplished by multiplying the number of meters by 1.094. For example, 600 meters \times 1.094 = 656.4 yards; the gunner would set his range scale at 650.

c. The AN/TVS 5 is an effective night fire aid. By using this device, the gunner can observe the area and detect and engage any suitable target. But, as usual, the device is only as good as its zero; the zeroing procedure requires practice to become proficient.

(1) *Mount the mounting bracket.* To mount the bracket, the gunner must ensure that the rear sight is in the down position. He then releases the catch on the left side of the top cover assembly and raises the cover to the upright position. He pushes the mounting bracket over the breech of the machine gun and slides the bracket rearward until it stops (Figure 5-32).

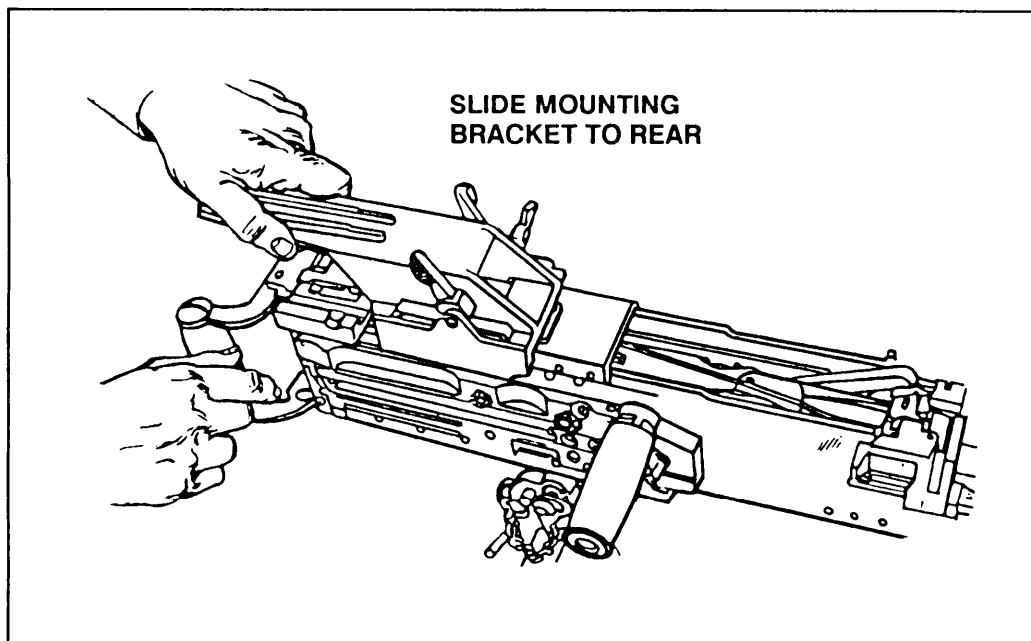

Figure 5-32. Mounting the bracket.

He pushes the three locking cams to secure the bracket (Figure 5-33) and closes the top cover assembly.

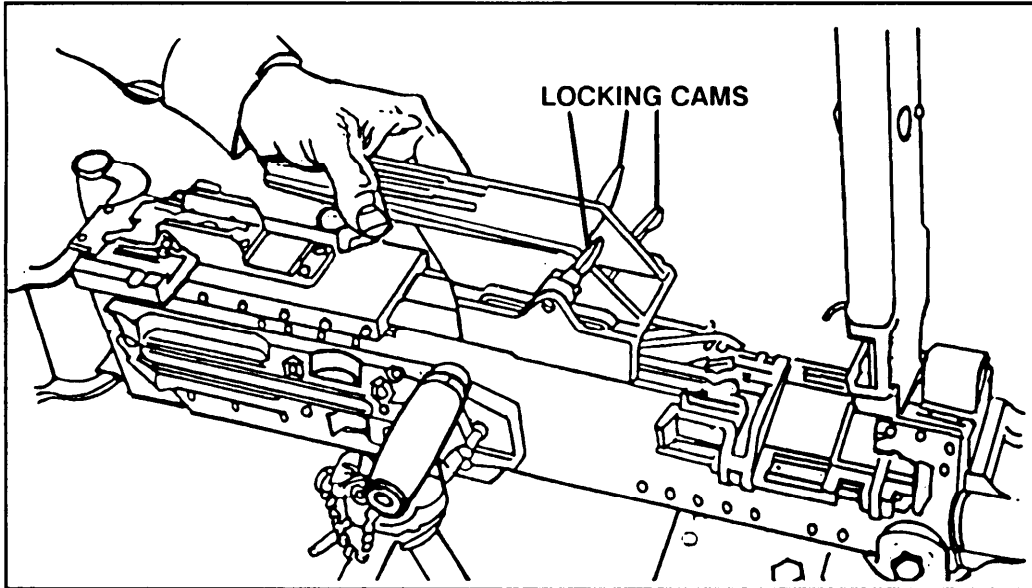

Figure 5-33. Securing the bracket.

(2) *Install the sight on the mount.* To install the sight, the gunner must align the scribe lines on the sight with the scribe lines on the bracket. He places the sight in the groove at the top of the bracket and tightens the lever screw to secure the sight to the bracket (Figure 5-34).

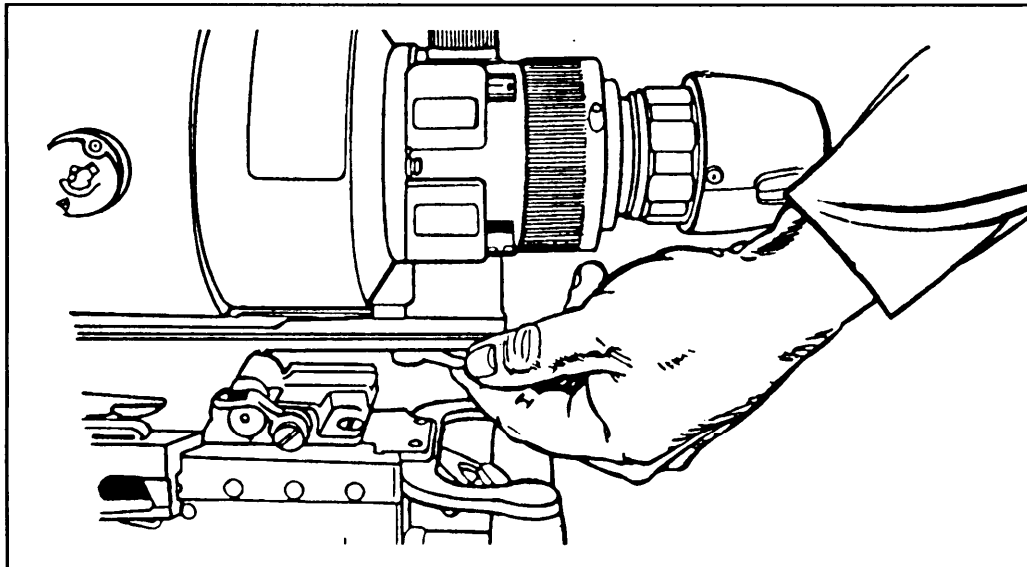

Figure 5-34. Securing the sight.

(3) *Zero the AN/TVS-5.* A gunner must zero the MG with its NVD on it before he can effectively engage targets with the AN/TVS-5. The zeroing of this device to the MG must be done at 50 meters. An M16A1, A2, or Canadian bull zero target may be used. The point of impact for either target must be 9.8 centimeters below the target aiming point. To accomplish this task, place the reticle aiming point on the target aiming point (Figure 5-35).

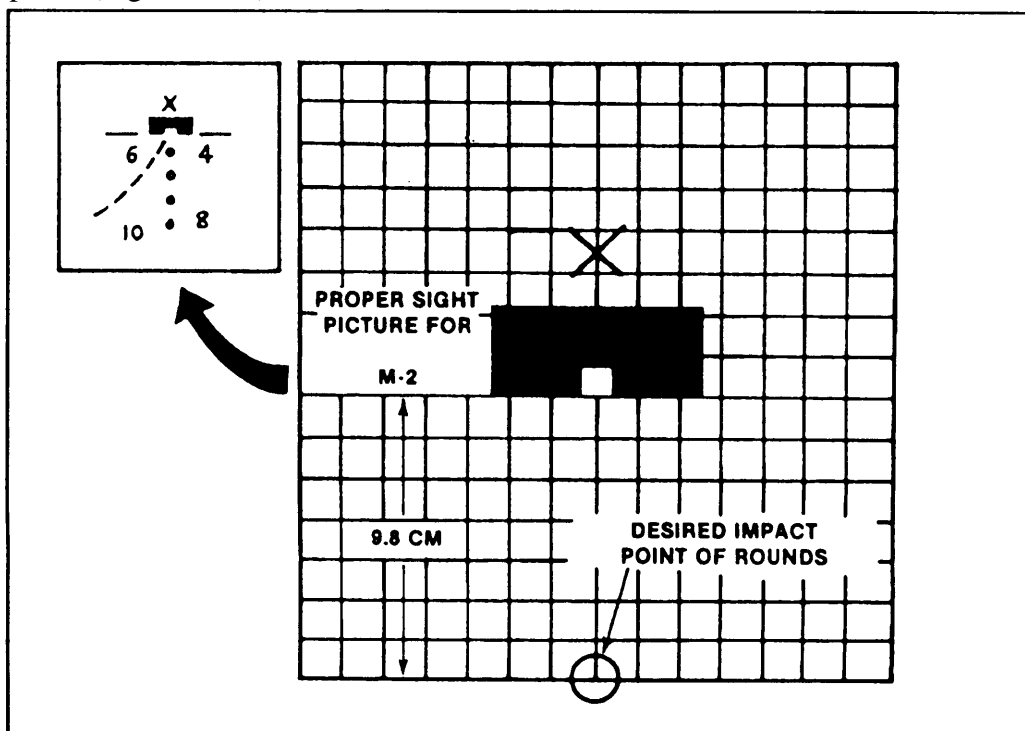

Figure 5-35. Desired impact point for the AN/TVS-5.

(a) Fire enough single-shot rounds to obtain a good shot group. Locate the center of the shot group. Adjust the AN/TVS-5 azimuth and elevation knobs until the shot group impacts 9.8 centimeters below the target aiming point. Move the weapon so that the reticle aiming point is again on the target aiming point. Repeat this process until the desired point of impact is obtained.

(b) When adjusting, move the azimuth or elevation adjustment actuator one click to move the strike of the round .5 inch at 50 meters. One click of adjustment will move the reticle about one square on the Canadian bull-type target.

NOTE: The lens cover with the peephole may be required to prevent scope washout from the muzzle flash.

(4) *Dismount the sight.* The gunner dismounts the sight from the bracket first by loosening the lever screws. Then he lifts the sight from the bracket. He must then dismount the bracket in the reverse mounting procedure.

5-14. TEN-METER FIRING EXERCISE

The purpose of 10-meter firing is to develop skills in the delivery of initial burst on target. When conducted properly, it will train gunners in the basic skills, such as 10-meter zero, controlled bursts, traverse, and traverse and search firing techniques. (See Appendix C for details on setup and conduct of firing.)

5-15. TRANSITION DAY FIRING EXERCISE

Transition day firing of the M2 machine gun will teach the gunner some techniques of fire that he may encounter in combat situations. The gunner will field zero his weapon and engage point and area targets from the tripod-mounted firing position. Within this training, the gunner will be required to apply all the fundamentals of gunnery learned in preparatory gunnery training and 10-meter firing. (See Appendix C for details on the setup and conduct of transition day fire.)

5-16. NBC FIRING

Since NBC plays an important part in our preparation for war on the modern battlefield, it is important that each soldier is prepared to accomplish the mission even if the area is contaminated and he must wear protective gear. (See Appendix C for details on setup and conduct of fire.)

5-17. NIGHT FIRE EXERCISE

The night fire exercise gives the soldiers the practical application of engaging targets using the AN/TVS-5 at night or during limited visibility. (See Appendix C for details on setup and conduct of fire.)

Section IV. ADVANCED GUNNERY

After firing 10-meter, day, NBC, and night, gunners need practice in applying what they have learned. They also need experience in engaging targets that depict realistic enemy formations. Advanced gunner exercises provide this experience in mounted, mounted NBC, and predetermined firing exercises.

5-18. OBJECTIVES

The objectives of the advanced gunnery phase are to prepare the gunners for combat. During this phase, training should be directed toward –

- Tracking and leading.
- Mounted target engagement techniques.
- Mounted NBC engagements.
- Predetermined fire techniques.

5-19. TRACKING AND LEADING EXERCISES

The gunner normally completes instruction in firing at stationary targets before he receives instruction in firing at moving targets. The technique of engaging a moving target differs from that of engaging a stationary target. The gun must be aimed ahead of the moving target a sufficient distance to cause the bullet and target to arrive at the aiming point at the same time. The distance is measured in target lengths. One target length as seen by the gunner is one lead. Leads are measured from the center of mass. The lead depends upon range, speed, and direction of movement of the target. To hit the target, the gunner aims at a point ahead of the target equal to the estimated number of leads, maintains the lead by tracking the target (manipulating the gun at the same angular speed as that of the target), and then fires. Fire is adjusted by observation of strike/tracer (Figure 5-36).

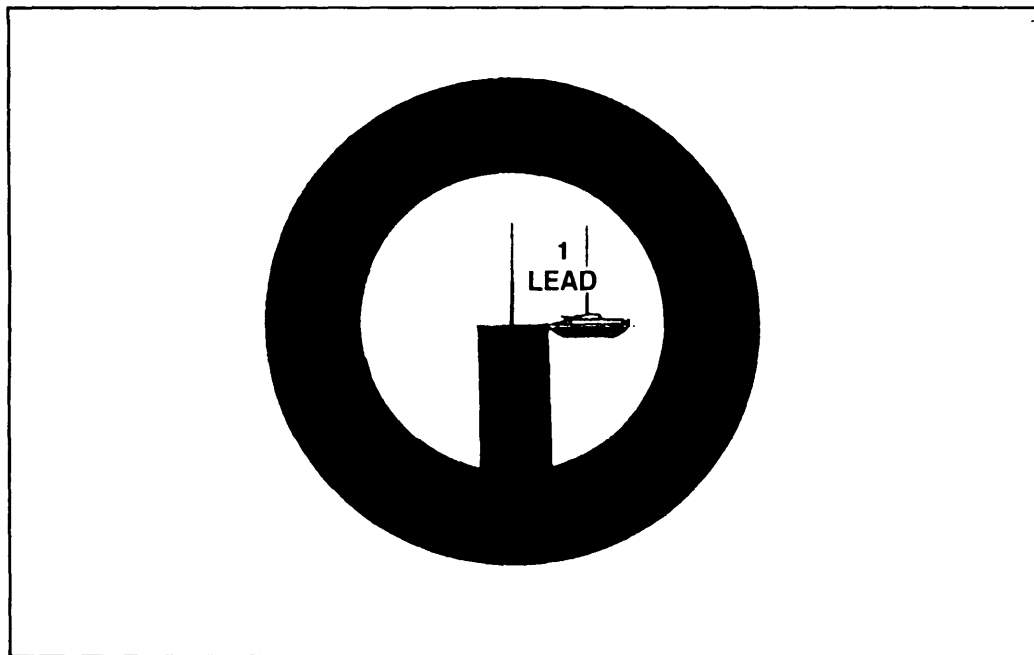

Figure 5-36. Lead technique.

a. **Tracking.** Tracking consists of maintaining correct alignment of the sights (with or without a lead) on a moving target by moving the gun at the same angular speed as that of the target.

(1) The gunner is required to aim at a prescribed point (center base to take advantage of the beaten zone) on the target and maintain that aim during uniform movement of the target. As instruction progresses, speeds used should differ for successive runs of the target. The speeds the 10-meter targets should move to represent speeds at various ranges are shown in Table 5-2.

TARGETS SPEEDS IN MILES PER HOUR	TARGET SPEEDS IN INCHES PER SECONDS CORRESPONDING TO—		
	300 M	500 M	900 M
7 1/2	6	4	2
15	12	8	4
30	24	15	9

Table 5-2. 10-meter moving target.

(2) The target handler must have practice in moving the target silhouette across the background at the varying speeds.

b. **Leading.** Mathematical computation or use of voluminous lead tables to obtain exact leads on a moving target are impractical in combat. The simple lead table shown in Table 5-3 gives the amount of lead necessary to hit a target moving at right angles (90 degrees) to direction to hit at speeds and ranges indicated.

SPEED IN MILES PER HOUR	RANGE OF TARGET		
	300 M	500 M	900 M
15	1/2 target length	1 target length	2 target lengths

Table 5-3. Lead table.

(1) The gunner must correct the lead as conditions change. If the target speed is 7 1/2 miles per hour, the amount of lead is half that shown in the table; at 30 miles per hour, double that shown. The angle at which the target is moving also alters the amount of lead taken. If the angle between line of fire and line of travel of the target is less than 45 degrees, use half the lead shown in the table.

(2) For targets moving directly toward the gun, the point of aim is placed on the center or the lower edge of the target, when possible. For targets moving directly away from the gun, the point of aim is placed on the center or upper edge of the target. Too much lead is better than too

little because the target runs into the fire; also, the observation of strike is easier. Intelligent use of the lead table includes immediate application of fire with estimated lead followed by necessary corrections based upon observation of strike/tracer.

c. **Tracking and Leading.** Combined tracking and leading exercises at 10 meters are used to gain proficiency in tracking the target. The gunner is required to repeat the tracking exercise while using a designated lead to simulate firing when his sights are properly aligned. As a further exercise in tracking and leading, the gunner may be required to track and lead moving targets at greater ranges. A vehicle can be run at right angles to the line of aim at ranges between 500 and 1,000 yards, and at varying speeds, averaging 15 miles per hour (Figure 5-37).

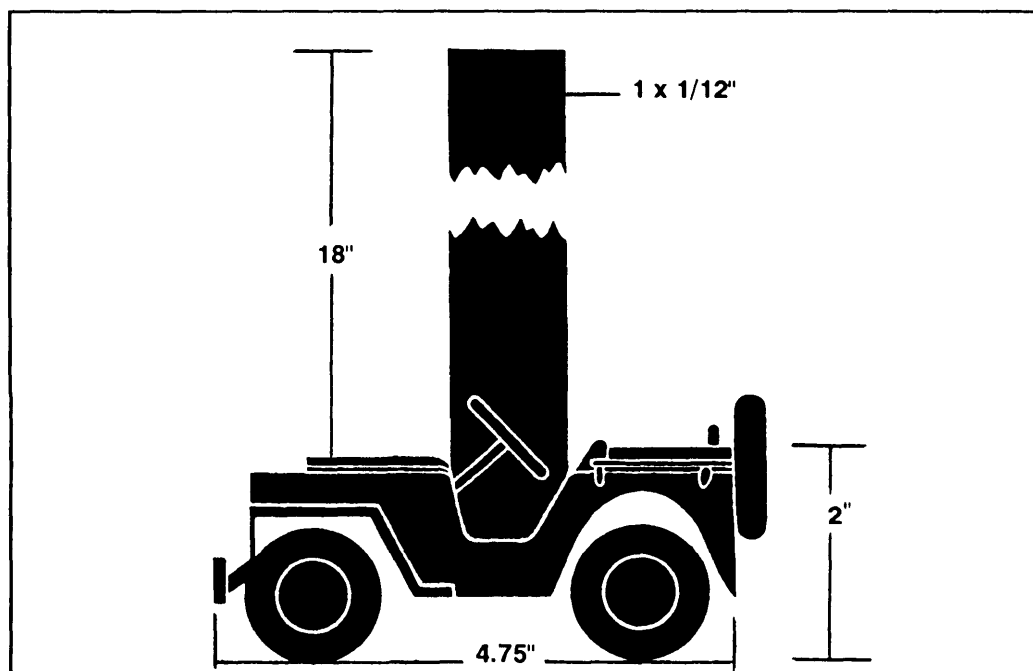

Figure 5-37. Aiming target used in tracking and leading exercise.

d. **Conducting the Lead Exercise (10-Meter).** The gunner is required to take a position at the gun, swing through the target's silhouette, and aim at a point ahead of the target equal to the prescribed lead from the center of mass. The gunner then directs the target handler to move the marking silhouette until the center of the target is at the point of aim. He repeats this procedure three times for each target lead announced. The target handler places his marking silhouette on the blank background, traces around it, and holds it in place for the gunner to aim, using the prescribed leads. Following the gunner's instructions, he moves the marking

silhouette until the gunner commands HOLD. He then places a pencil dot at this point and returns the silhouette to the original position. This procedure is followed until the gunner has completed three tries for each target lead announced. The three pencil dots for each target should fit within a one-centimeter circle. The exercise should be conducted for varying left and right leads.

5-20. MOUNTED FIRING EXERCISE

The purpose of the mounted firing exercise is to teach the gunner techniques of firing the M2 MG from a mounted platform and to develop the gunner's ability to fire the M2 with it mounted on its primary carrier. (See Appendix C for details on the setup and conduct of fire.)

5-21. MOUNTED NBC FIRING EXERCISE

The probability of fighting mounted in a tactical environment that has been contaminated by NBC agents is very likely; therefore, gunners must be trained to engage targets while in a mounted NBC posture. (See Appendix C for details on the setup and conduct of fire.)

5-22. PREDETERMINED FIRING EXERCISE

The predetermined firing exercises are designed to instruct the gunners on preparing and using range cards during any visibility conditions. (See Appendix C for details on setup and conduct of fire.)

CHAPTER 6

COMBAT TECHNIQUES OF FIRE

Technique of fire is the method of delivering and controlling fire. Each member of the machine gun crew must be trained in standard methods of applying fire, either as a crewmember or a gunner, and must perform his assigned task automatically and effectively. The simplest and most effective technique of delivering fire with the machine gun mounted on its ground or vehicular mount is to align the sights of the gun on the target and fire; this is called direct laying. At times, techniques of fire other than direct laying are more appropriate and effective. When delivering overhead fire or fire from position defilade, the gunner must use the appropriate technique.

Section I. FUNDAMENTALS

Before the machine gun can be employed to the best advantage using any firing technique, certain fundamentals must be understood and applied. These include:

- Characteristics of fire.
- Classes of fire.
- Fire control.
- Target types and methods of engagement.
- Overhead fire.
- Methods of laying the gun.
- Firing from position defilade.
- Final protective fires.

6-1. CHARACTERISTICS OF FIRE

The gunner's knowledge of his machine gun is not complete until he learns something of the action and effect of the projectiles when fired. This section discusses various characteristics of machine gun fire, including trajectory, cone of fire, and the beaten zone.

a. **Trajectory.** The trajectory is the curved path of the projectile in its flight from the muzzle of the weapon to its impact. The major factors that influence the trajectory are the velocity of the round, gravity, rotation of the round, and resistance of the air. The farther the round travels, the greater the curve of the trajectory. The highest point of the trajectory is called the maximum ordinate. This is a point approximately two-thirds of

the distance from the gun to the target. The maximum ordinate increases as the range increases (Figure 6-1).

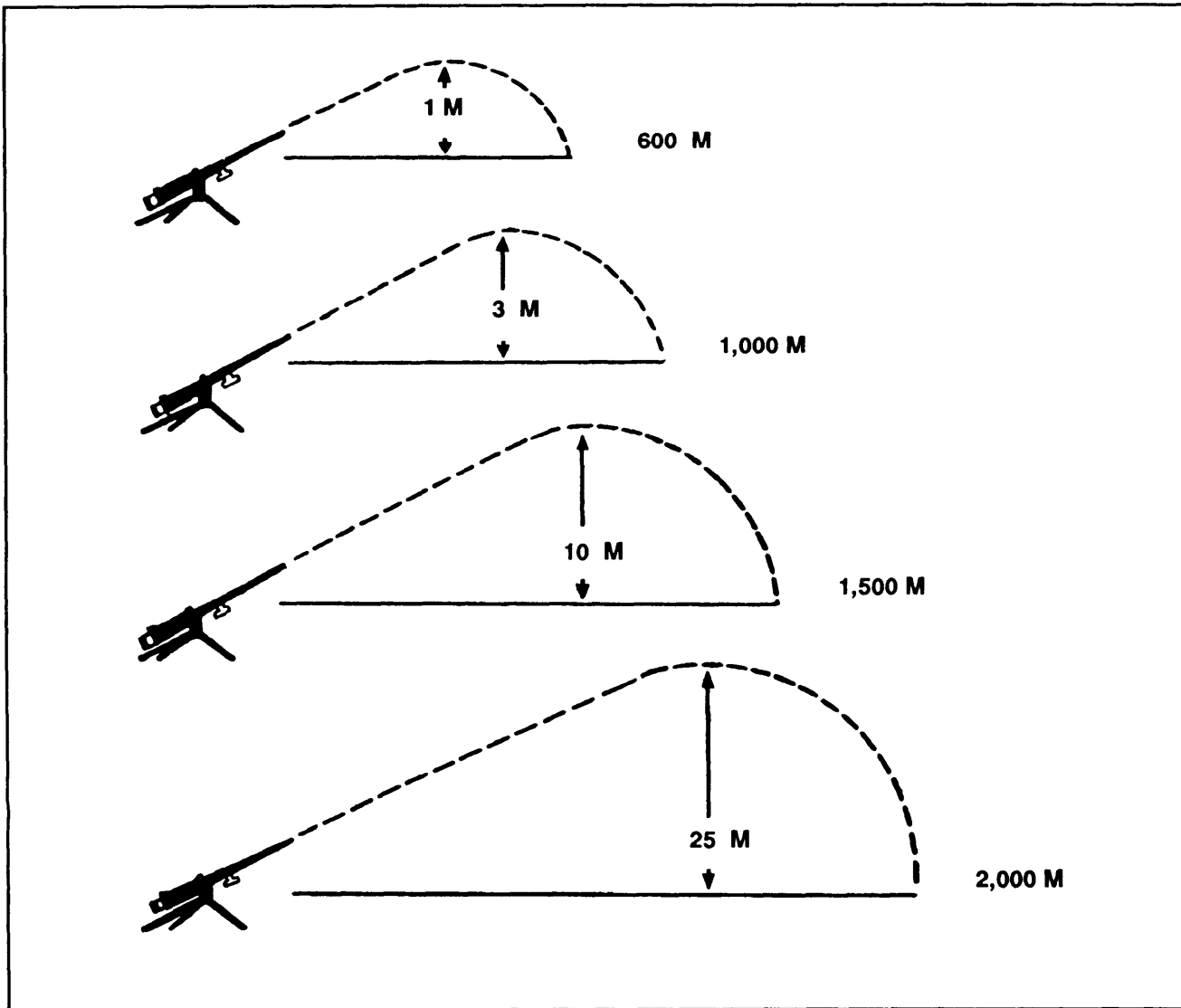

Figure 6-1. Maximum ordinates at key ranges.

b. **Cone of Fire.** When the weapon is fired automatically in bursts, all the rounds do not follow the same path. This is due to the vibrations of the gun and mount, variations in ammunition, and atmospheric conditions, which cause the rounds to follow a slightly different trajectory. This group of trajectories formed by a single burst is called the cone of fire (Figure 6-2).

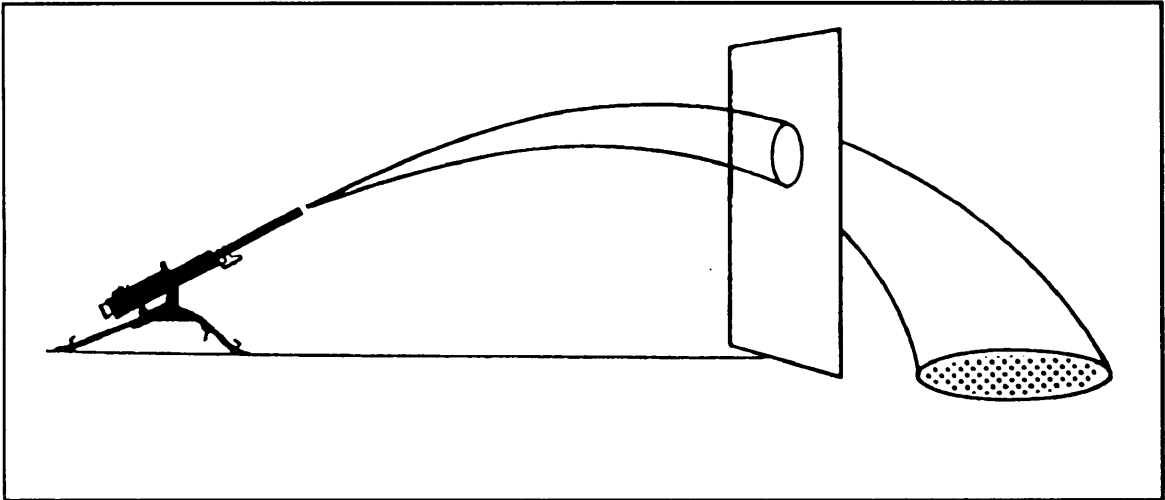

Figure 6-2. Cone of fire.

c. **Beaten Zone.** The beaten zone is an elliptical pattern formed by the cone of fire as it strikes the ground. The beaten zone is always about 2 meters in width.

(1) *Effect of range.* As the range to the target increases, the beaten zone becomes shorter and wider.

(2) *Effect of terrain.* The length of the beaten zone for any given range will vary according to the slope of the ground. On rising ground, the beaten zone becomes shorter but remains the same width. On ground that slopes away from the gun, the beaten zone becomes longer but remains the same width.

6-2. CLASSES OF FIRE

Machine gun fire is classified with respect to the ground (Figure 6-3, page 6-4), the target (Figure 6-4, page 6-5), and the gun (Figure 6-5, page 6-7).

a. Classes of Fire with Respect to the Ground.

(1) *Plunging fire.* Fire in which the angle of fall of the rounds (with reference to the slope of the ground) is such that the danger space is confined to the beaten zone, and the length of the beaten zone is materially shortened. Plunging fire is obtained when firing from high ground to low ground, when firing from low ground to high ground, and when firing at long ranges.

(2) *Grazing fire.* Grazing fire is fire in which the center of the cone of fire does not rise more than one meter above the ground. When firing over level or uniformly sloping terrain, the maximum extent of grazing fire obtainable is about 700 meters.

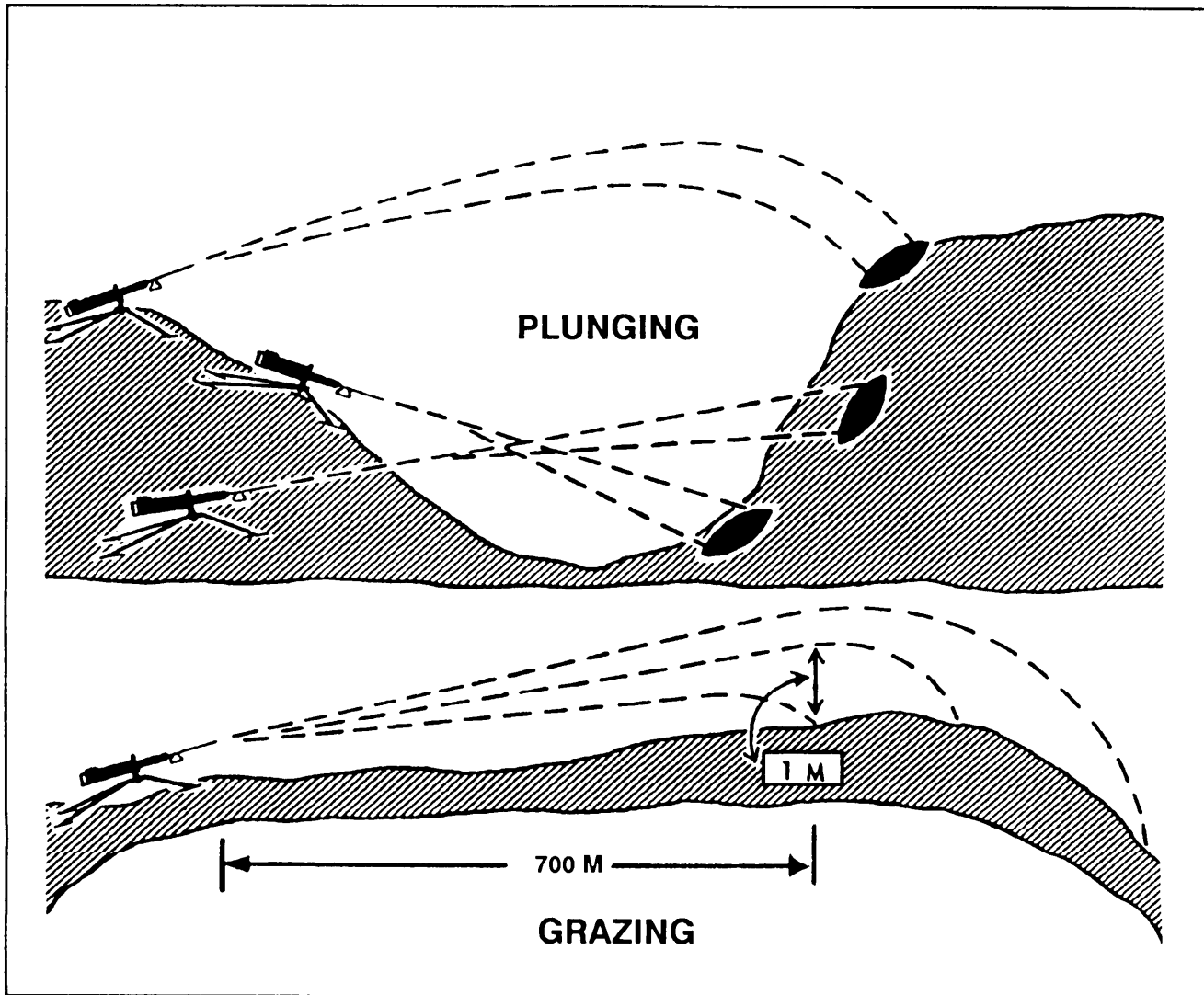

Figure 6-3. Classes of fire with respect to the ground.

b. Classes of Fire with Respect to the Target.

(1) *Frontal*. The long axis of the beaten zone is at a right angle to the long axis of the target.

(2) *Flanking*. Fire is delivered against the flank of a target.

(3) *Oblique*. The long axis of the beaten zone is at an angle (but not a right angle) to the long axis of the target.

(4) *Enfilade*. The long axis of the beaten zone coincides or nearly coincides with the long axis of the target. This class of fire is either frontal or flanking. It is the most desirable class of fire with respect to the target because it makes maximum use of the beaten zone.

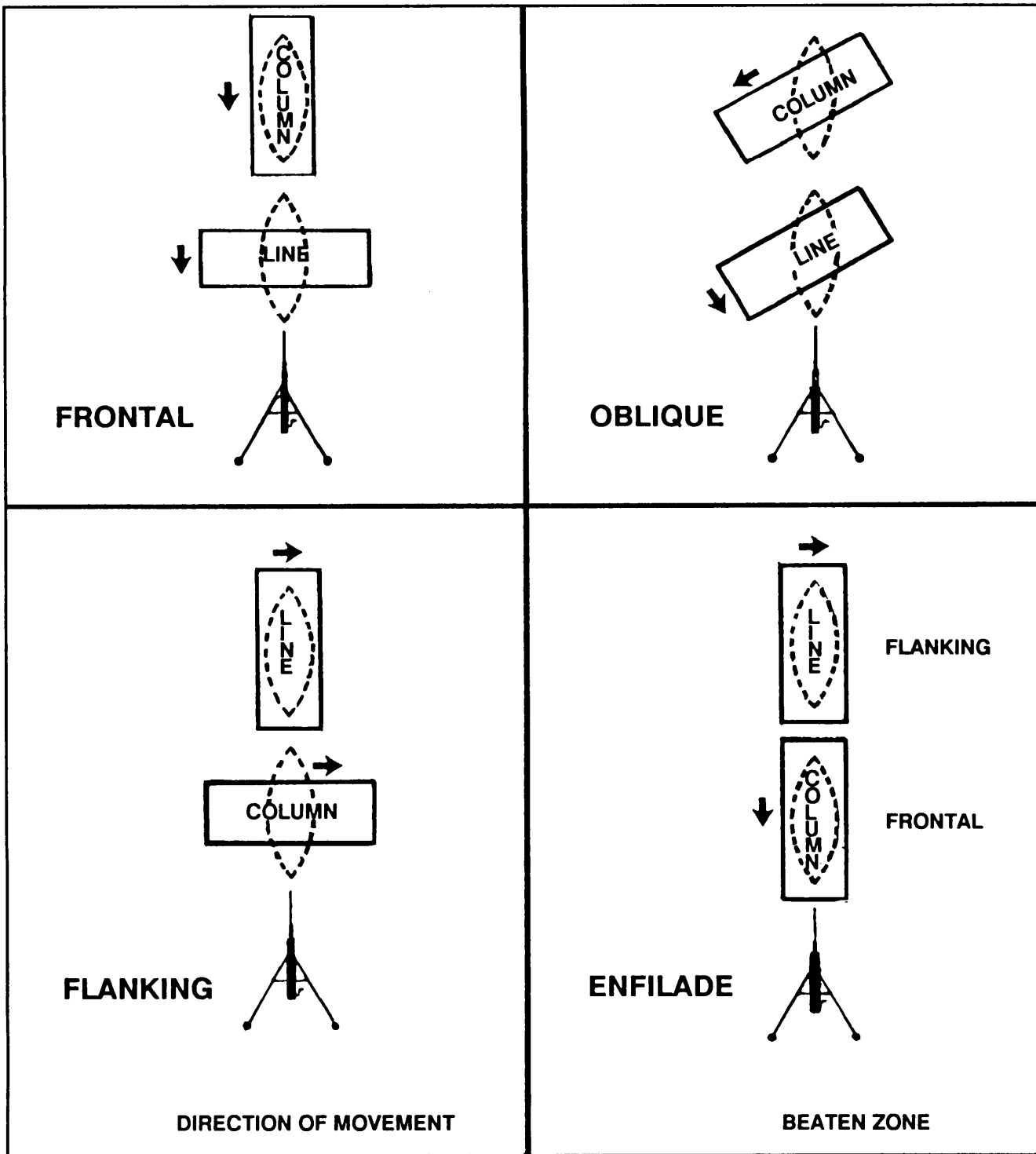

Figure 6-4. Classes of with respect to the target.

c. Classes of Fire with Respect to the Gun.

(1) *Fixed fire.* This is fire delivered on a point target with little or no manipulation needed. After the initial burst, the gunners will follow any change or movement of the target without command.

(2) *Traversing fire.* This is fire distributed against a wide target requiring successive changes in the direction of the gun. When engaging a wide target requiring traversing fire, the gunner should select successive aiming points throughout the target area. These aiming points should be close enough together to ensure adequate target coverage; however, they need not be so close as to be wasteful of ammunition by concentrating a heavy volume of fire in a small area. Two clicks on the traversing handwheel after each burst ensure coverage (2 clicks = 2 mils = constant width of beaten zone).

(3) *Searching fire.* This is fire delivered against a deep target or a target that has depth, requiring changes in elevation of the gun. The amount of elevation change depends upon the range and slope of the ground.

(4) *Traversing and searching fire.* This is fire delivered both in width and depth by changes in direction and elevation. It is employed against a target whose long axis is oblique to the direction of the fire.

(5) *Swinging traverse.* This is employed against targets that require major changes in direction but little or no change in elevation. Targets may be dense, wide, in close formations moving slowly toward or away from the gun, or vehicles or mounted troops moving across the front. The traversing slide lock lever is loosened enough to permit the gunner to swing the gun laterally.

(6) *Free gun.* This is when fire is delivered against moving targets that must be rapidly engaged with fast changes in both direction and elevation. Examples are aerial targets, vehicles, mounted troops, or infantry in relatively close formations moving rapidly toward or away from the gun position. To fire free gun on the M3 tripod mount, remove the T&E mechanism from the receiver and traversing bar and put it down. When firing swinging traverse and free gun, the weapon is normally fired at the cyclic rate of fire which is in excess of 450 rounds per minute. This consumes a lot of ammunition, and there is no beaten zone because each round seeks its own area of impact.

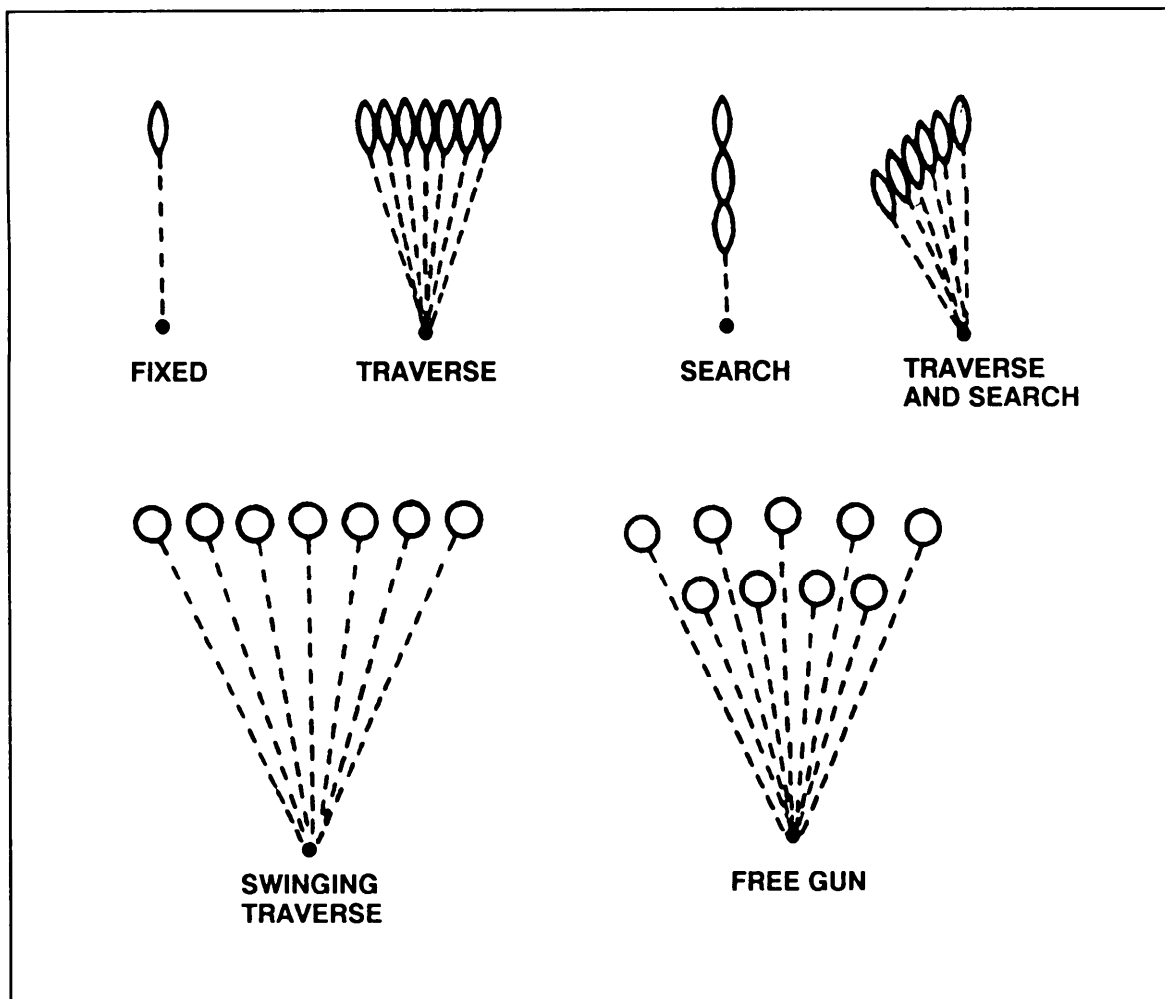

Figure 6-5. Classes of fire with respect to the gun.

Section II. FIRE CONTROL

Fire control of machine guns includes all operations connected with the preparation and actual application of effective fire on a target. It implies the-ability of the leader to-open fire at the instant he desires, to adjust the fire of the gun(s) on the target, to regulate the rate of fire, to shift from one target to another, and to cease firing. This ability to exercise proper fire control depends primarily on the discipline and the proper training of the crew. Failure to exercise fire control results in danger to friendly troops, loss of surprise, premature disclosure of positions, application of fire on unimportant targets, loss of time in adjusting fire, and waste of ammunition.

6-3. METHODS OF FIRE CONTROL

Of the several methods of controlling machine gun fire, the noise of battle will limit the use of some. Therefore, the leader must select the method or combination of methods that will best accomplish his purpose. The chain of fire control begins with the leader. He is responsible for both the technical and tactical employment of the gun and the training of the crew. He is responsible for passing on to the crewmembers all instructions and orders from his next higher leader regarding the situation and mission. He assigns sectors of fire and firing positions, designates targets to be engaged, adjusts fire, and ensures effective coverage of the targets.

a. **Oral.** Oral control is effective unless the leader is too far away from the gun crew(s), or the noise of battle makes it impossible for the gun crew(s) to hear him.

b. **Arm-and-Hand Signals.** This is an effective method when the gun crew(s) can see the leader. All crewmembers must understand the standard arm-and-hand signals used to control machine gun fire.

c. **Prearranged Signals.** These are either visual or sound signals such as pyrotechnics or blasts on a whistle. These signals should be included in the units' SOPs and must be clearly understood by all crewmembers.

d. **Personal Contact.** In many situations, the leader must move to individual crewmembers to issue orders. This method is used more than any other by small-unit leaders. The leader must use maximum cover and concealment to keep from disclosing the gun crew's position.

e. **Standing Operating Procedures.** SOPs cover actions the gun crews perform without command because they were developed and practiced during the training of the gun crews. Their application eliminates many commands and simplifies the leader's job of fire control.

6-4. TARGETS AND THEIR ENGAGEMENT

Targets presented to the machine gunners during combat will in most cases consist of enemy soldiers in various formations, which require distribution and concentration of fire. These targets have width and depth, and the application of machine gun fire is designed to completely cover the area in which the enemy is known or suspected to be. These targets may be easy to see or may be indistinct and difficult to locate.

a. When machine gun fire is under direct control of a leader, he designates the midpoint and flanks or ends of a target unless they are obvious to the gun crew(s). When a target other than a point target is engaged by two gunners, it is always divided. Each gunner applies his fire to that portion of the target corresponding to his position with relation to the other gun. Normally, each gunner engages one-half of the target;

however, gunners must be prepared to engage the entire target if necessary. Gunners continue to fire on the target until it is neutralized or until another signal is received from the leader.

b. The gunner's positions (including vehicular-mounted) should be numbered so each gunner will know which portion of a target he should engage. It should be emphasized that the positions are numbered – not the guns or gunners. To ensure that gunners react quickly and properly when they detect a target or when a target is designated by the leader, standard methods of applying fire to the various type targets are taught. These methods are the same for ground and vehicular-mounted guns. The following are the different types of targets and how they are engaged with the MG.

(1) Point targets are targets that require the use of a single aiming point. Enemy bunkers, weapon emplacements, vehicles, small groups of soldiers, and aerial targets such as helicopters or descending paratroopers are examples of point targets. A point target is engaged with fixed fire. If the target moves after the initial burst, the gun crew(s) keeps fire on the target by following its movement with the gun(s).

(2) Linear targets have sufficient width to require traversing fire and no more depth than can be effectively covered by the beaten zone. Linear targets are engaged with traversing fire.

(a) Two guns, normal division. The target is divided at the midpoint; the right gun engages the right half of the target, and the gun on the left engages the left half of the target. The point of initial lay and adjustment for both guns is at the midpoint of the target. After adjusting on the midpoint, the right gun traverses the right half of the target to include one aiming point beyond the last visible target flank and returns to the midpoint.

(b) Two guns, special division. If one portion of the target presents a greater threat than another, the target can be divided so fire is concentrated on that portion presenting the greatest threat. The special division of the target is accomplished by a subsequent fire command after firing begins. The gunners initially lay at the midpoint, regardless of the special division to be made, thus precluding confusion.

(c) One gun. A single gunner must engage the entire width of a linear target. The point of the initial lay and adjustment is on the midpoint, or that portion of the target presenting the greatest threat. The gunner traverses to either flank and then covers the remainder of the target (Figure 6-6, page 6-10).

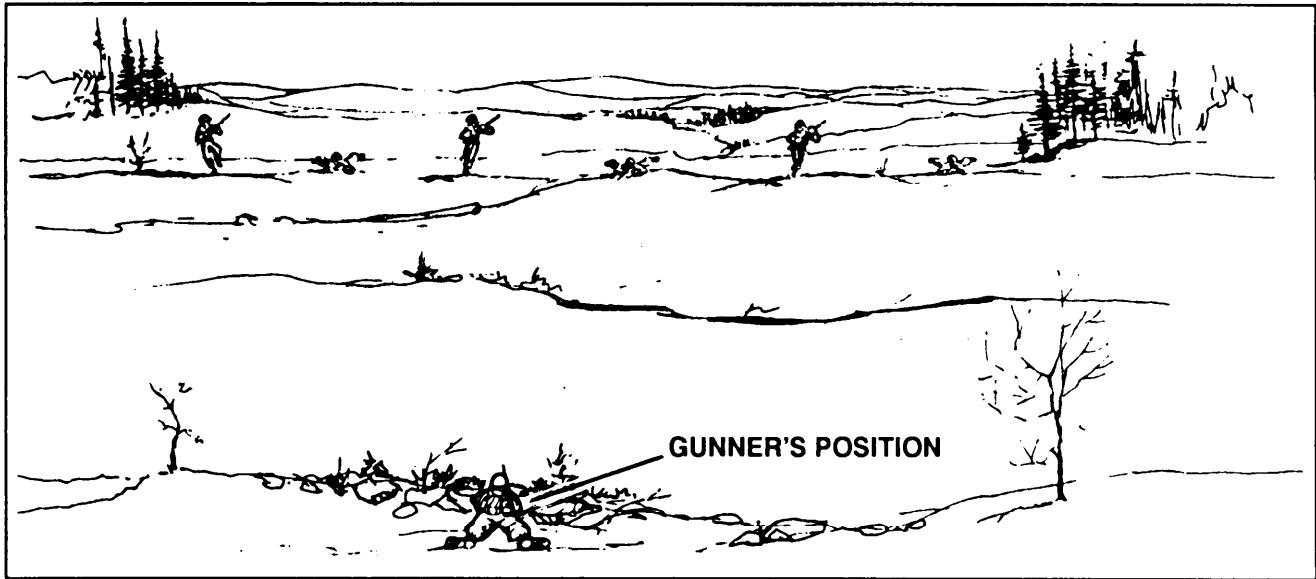

Figure 6-6. Linear target and one gun.

(3) Linear targets with depth are targets that have sufficient width to require traversing fire and depth which cannot be covered by the beaten zone. A combined change in direction and elevation (traversing and searching fire) is required to maintain effective fire on these targets (Figure 6-7). Linear targets with depth are engaged with traversing and searching fire. When range is announced, the range to the midpoint is given.



Figure 6-7. Linear target with depth.

(a) Two guns. The method of division, the point of initial lay and adjustment, and the extent of manipulation for both guns are the same as prescribed for linear targets. The gunners, however, apply enough search between each burst to ensure the center of the beaten zone is maintained at the center base of the target (Figure 6-8).

(b) One gun. A single gunner initially lays and adjusts on the midpoint of a linear target with depth unless some other portion of the target presents a greater threat. The gunner traverses and searches to the near flank, then he covers the entire target area (Figure 6-8).

(4) Deep targets have depth but very little width and can be effectively covered by searching fire (Figure 6-9, page 6-12). When the range is announced, it is given to the midpoint of the target.

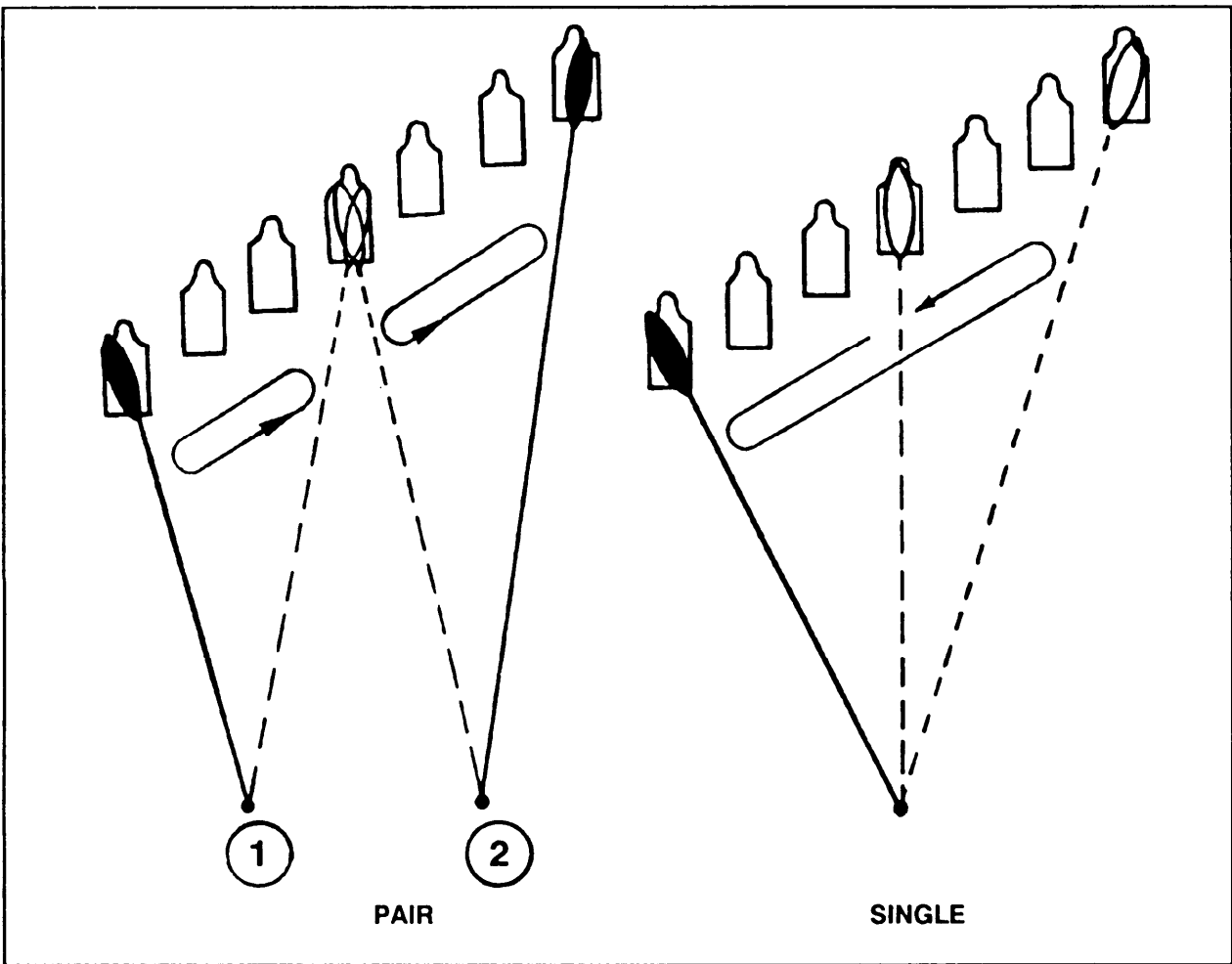

Figure 6-8. Engagement of linear targets with depth.

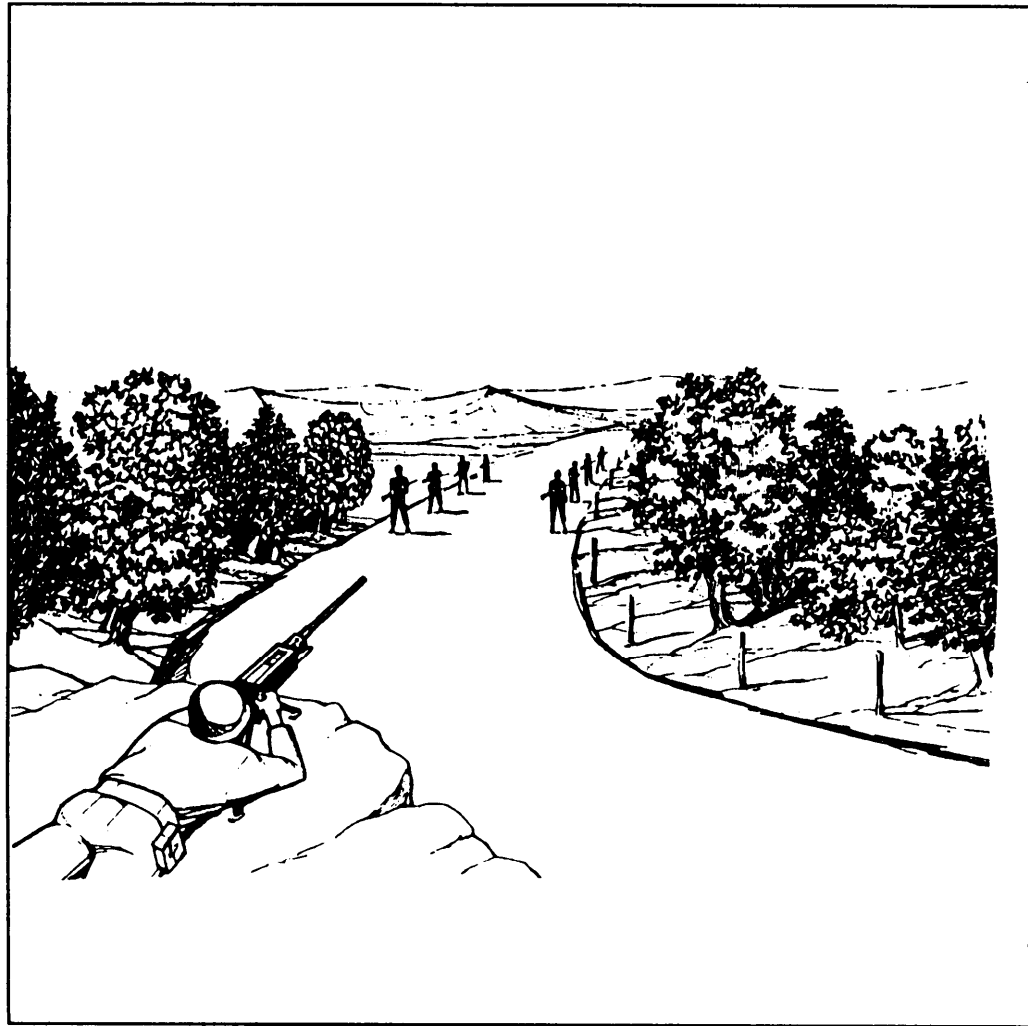

Figure 6-9. Deep target.

(a) Two guns. The point of initial lay of both guns is on the midpoint, which is also the point of division. Since enfilade fire is delivered, it is not necessary to adjust on the midpoint of the target because the long axis of the beaten zone will compensate for missing the midpoint. However, should the gunner's beaten zone be out of the lateral confines of the target, it will be necessary to adjust fires into the target area. After the initial bursts, the right gun searches to the near end of the target, and the left gun searches to the far end of the target. Both gunners then reverse their direction of search and return to the midpoint (Figure 6-10).

(b) One gun. A single gunner initially lays and fires at the midpoint of a deep target, unless another portion of the target presents a greater threat. The gunner immediately searches to the near end, then covers the entire target (Figure 6-10).

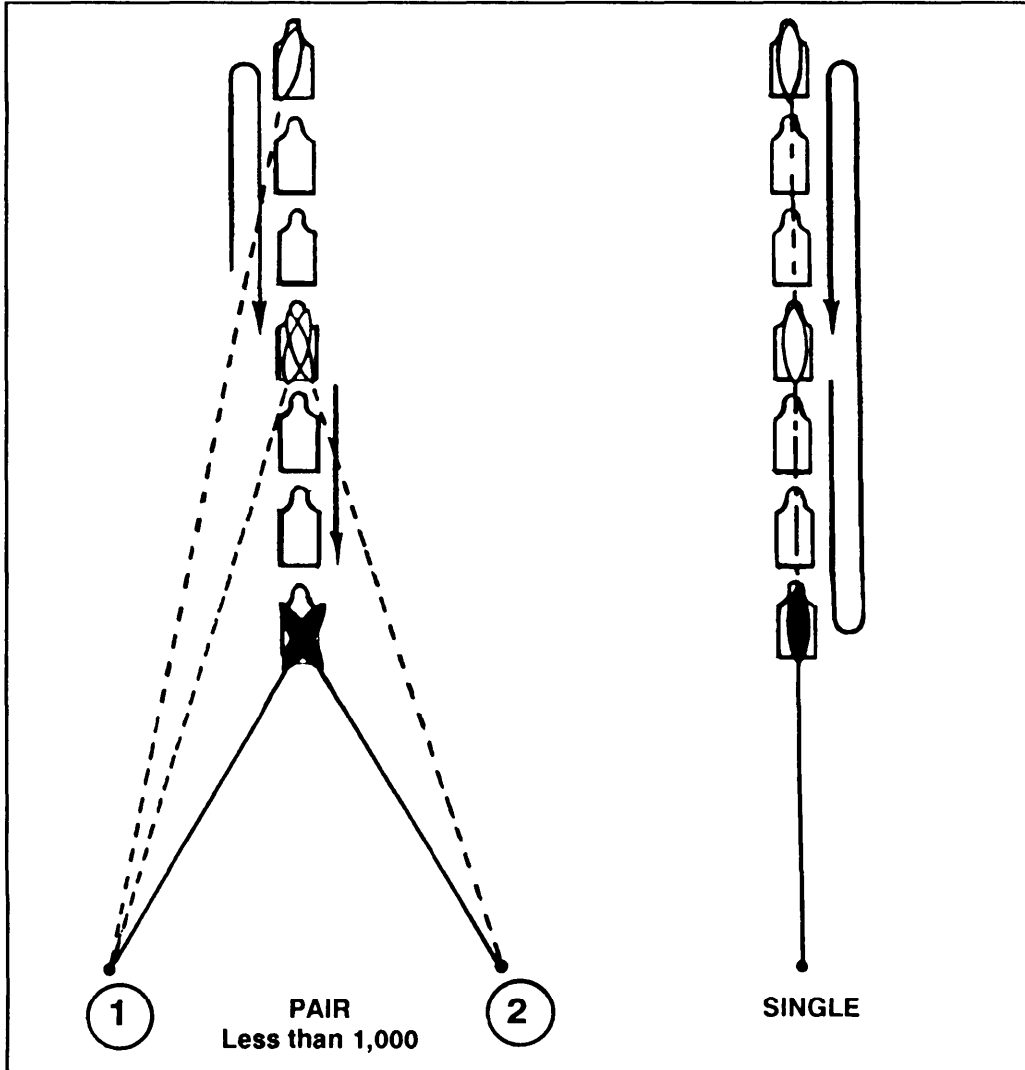

Figure 6-10. Engagement of deep targets.

(5) Area targets as discussed in this manual have considerable width and depth, and they require extensive traversing and searching fires. This type target exists when the enemy is known to be in a certain area, but his exact location is not known. A hilltop is a typical area target. The leader designates an area target by indicating to the gun crew(s) the width and depth of the target.

(a) Two guns. The target is divided at the center of mass; the right gun fires on the right half and the left gun fires on the left half. The point of initial lay and adjustment for both guns is on the center of mass. After adjusting on the center of mass, fire is distributed by determining the size of the beaten zones and applying direction and elevation changes that cause the most effective coverage of the target area. Both guns traverse and search their respective halves to the flanks, then return to the midpoint (Figure 6-11).

(b) One gun. A single gunner engages an area target by laying and adjusting on the center of mass, traversing and searching to either flank, then reversing the direction, traversing and searching to the other flank (Figure 6-11).

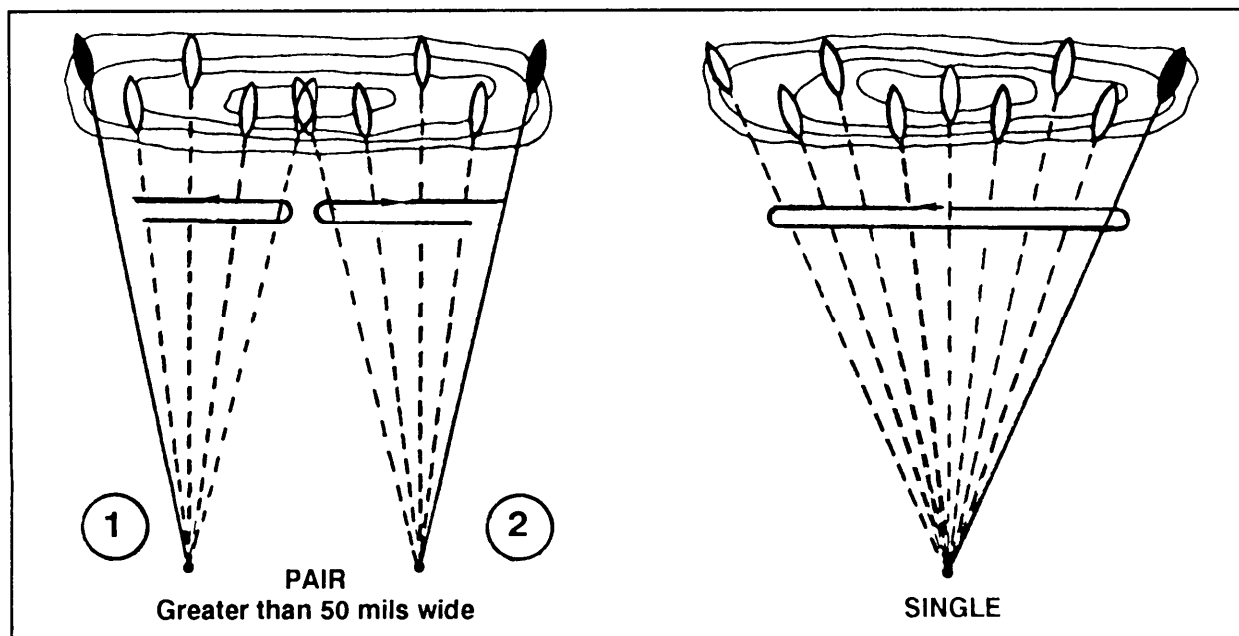

Figure 6-11. Engagement of area targets (objective).

NOTE: After the target is engaged in whatever formation it is in, the configuration of that target will change. The gunner must be trained to compensate for this change and still place effective fire on the target.

6-5. OVERHEAD FIRE

Overhead fire is fire delivered over the heads of friendly troops. A machine gun on a tripod is capable of delivering this type of fire because of the small and uniform dispersion of the cone of fire. In the attack, the

use of overhead fire permits the machine gun to support the advance of rifle units. Sectors of fire allow the trainers to plan safe training while still incorporating the combat realities of overhead fires.

a. **Minimum Clearance.** The center of the cone of fire must clear the heads of the friendly troops by a prescribed distance (Figure 6-12). This distance, known as minimum clearance, is found by adding together the following elements:

- The height of a standing man, taken as 1.8 meters.
- Half the vertical dimension of the 100-percent cone of fire at the range to the troops.
- A margin of safety equal to the vertical distance which extends a 5-mil angle at the gun or 3 meters, whichever is greater.
- An additional allowance to compensate for a 15-percent error in range determination.

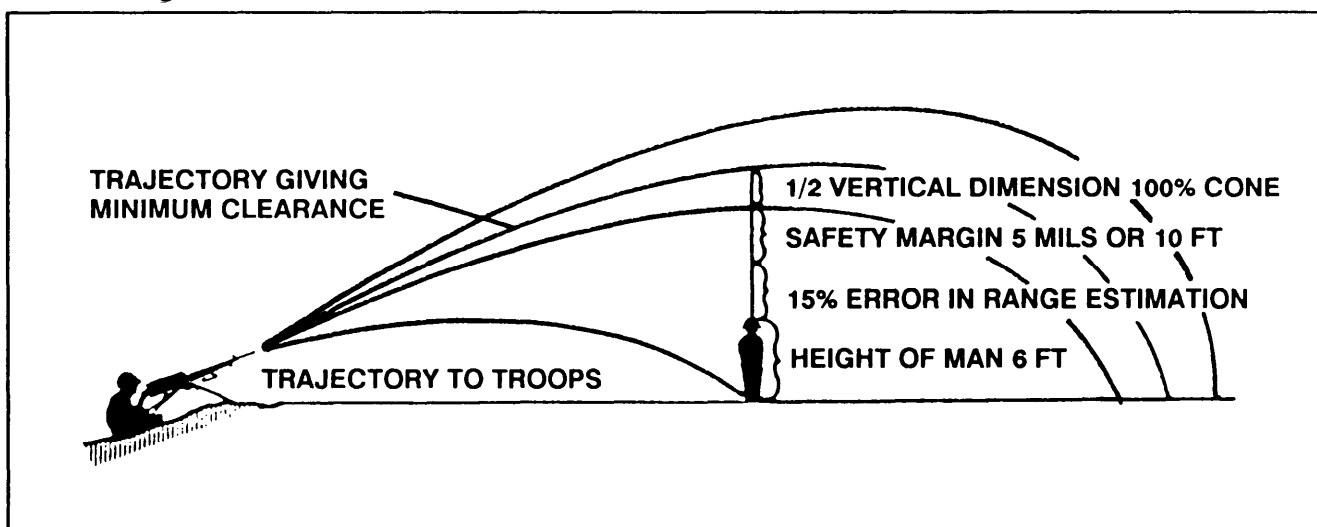

Figure 6-12. Components of minimum clearance.

b. **Safety Angles.** To obtain this minimum clearance, the gun is elevated so that the center of the cone of fire is raised from the feet-of the friendly troops to maintain clearance above their head. The amount of this elevation change is known as the safety angle. When the gun is fired from the tripod with the required safety angle, the center of impact determines the shortest range at which fire can be delivered over the heads of friendly troops. The range from the gun to the point of strike is called the corresponding range. When the ground is level or uniformly sloping between the gun and the target, the corresponding range for the safety angle used is obtained by converting the angle of elevation expressed in mils into range.

c. **Conditions.** Overhead fire is used only when the following conditions have been met:

- (1) The safety limit has been determined and has been identified on the ground.
- (2) The gun mount is firmly seated.
- (3) Friendly troops have been notified, if at all possible, that fire is to be delivered over them.
- (4) The rate of fire does not exceed 40 rounds per minute.
- (5) The gun barrel is not badly worn. This condition is indicated by excessive muzzle blast.

d. **Uneven Terrain.** Level or uniformly sloping ground is seldom found in the field. This limits the use of firing tables and corresponding ranges in determining the limit of troop safety. In lieu of firing tables, a rule of thumb has been devised to give the gunner a simple method of checking for troop safety.

(1) The gunner's rule can be applied when the friendly troops are at least 350 meters in front of the gun position, and the range to the target is 850 meters or less (Figure 6-13).

(a) Lay the gun on the target with the correct sight setting to hit the target.

(b) Without disturbing the lay of the gun, set the rear sight at a range of 1,600 meters.

(c) Look through the sights and notice where the new line of aim strikes the ground. This is the limit of troop safety. When the feet of the friendly troops reach this point, fire must be lifted or shifted.

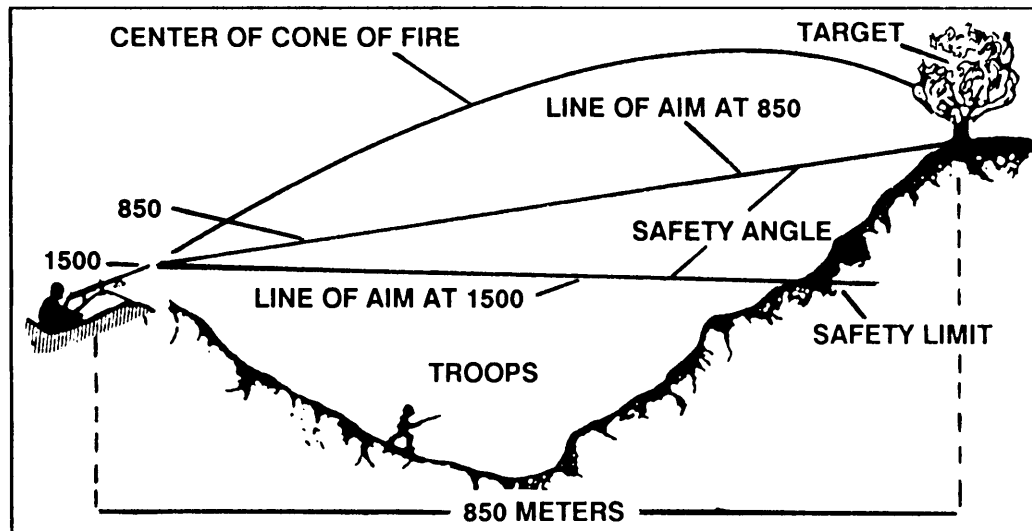

Figure 6-13. Application of gunner's rule.

(2) When the range to the target is greater than 850 meters, overhead fire should be delivered only in an emergency and then only out to a range in which either the tracers or the strike of the bullets can be seen by the gunner. In this situation the leader's rule applies (Figure 6-14).

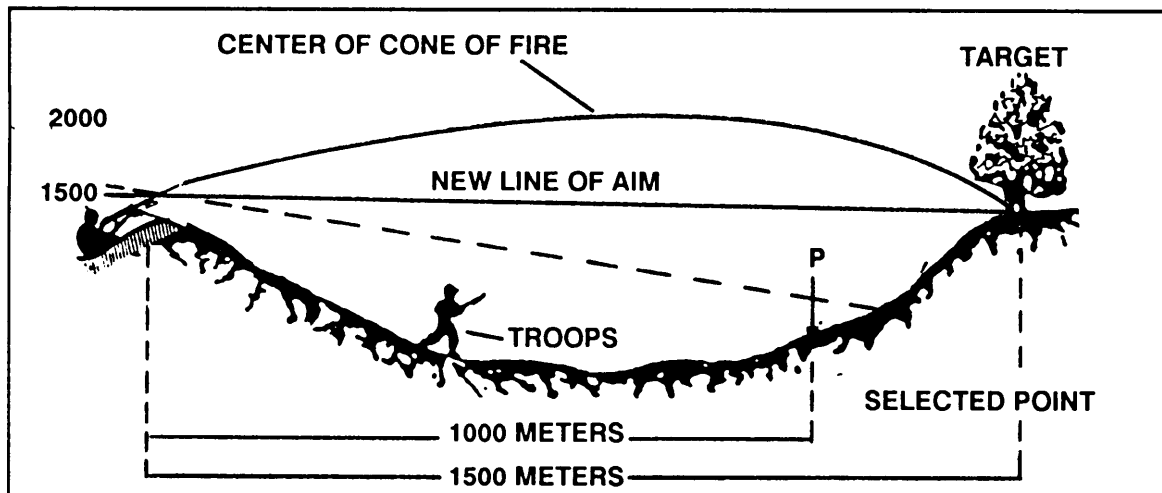

Figure 6-14. Application of leader's rule.

The platoon or section leader uses the leader's rule only when the target is greater than 850 meters. The rule is as follows:

- (a) Select a point on the ground where it is believed friendly troops can advance with safety.
- (b) Determine the range to this point by the most accurate means available.
- (c) Lay the gun on the target with the correct sight setting to hit the target.
- (d) Without disturbing the lay of the gun, set the rear sight to 1,600 meters, or the range to the target plus 500 meters, whichever is greater. Under no conditions should the sight setting be less than 1,500 meters.
- (e) Note the point where the new line of aim strikes the ground.
 - If it strikes at the selected point, that point marks the limit of safety.
 - If it strikes short of the selected point, it is safe for troops to advance to the point where the line of aim strikes the ground and to an unknown point beyond. If it is desired to fire after friendly troops advance farther than the point where the line of aim strikes the ground, this farther point is determined by testing new selected points until the line of aim and the selected point coincide.

- If it clears the selected point, it is safe for the troops to advance to the selected point and to an unknown point beyond. If it is desired to have troops advance beyond the selected point, this farther point must be determined by testing new selected points until the line of aim and the selected point coincide. This point marks the line of safety.

e. **Precautions.** The following safety precautions *must* be observed in delivering overhead fire.

- (1) Firmly emplace the tripod mount.
- (2) Use depression stops to prevent the muzzle of the gun from accidentally being lowered below the safety limit.
- (3) Do not deliver overhead fire through trees.
- (4) Inform commanders of friendly troops when fire is to be delivered over their heads.
- (5) Ensure that all members of the gun crew(s) are aware of the safety limit.
- (6) Do not deliver overhead fire if the range from the gun to the target is less than 350 meters or more than 850 meters.
- (7) Do not use a barrel that has excessive muzzle blast or is otherwise determined to be badly worn.
- (8) Do not lay machine guns so their fire will cross at any point over the heads of friendly troops.

6-6. DEFILADE POSITIONS

To achieve maximum effectiveness, the machine gun must be employed using the technique of direct lay; however, at times it may be desirable to employ guns from defilade positions.

a. **Full Defilade.** A machine gun is in defilade when the gun and its crew are hidden from enemy ground observation by a land mass such as the crest of a hill. The position may be on the reverse side of the crest or the forward slope of the next higher ground (Figure 6-15). The gun must fire up and over the hill. Fire must be observed and adjusted by a crewmember who can observe the target from a position on a flank or to the rear of the gun (on higher ground). A defilade position allows little opportunity to engage new targets.

b. **Partial Defilade.** A machine gun is in partial defilade when a mask (usually the crest of a hill) provides the gun and gunner with some protection from enemy direct fire, but the gunner is able to engage the target using direct laying techniques. The gun is far enough up the slope so that the gunner can see the target through the sights but the lower portion

of his body and lower portion of the gun are protected by the mask. Partial defilade positions are desirable when a fire mission cannot be accomplished from a defilade position.

c. **Advantages.** The gun and crew have cover and concealment from direct fire weapons. The crew has some freedom of movement in the vicinity of the gun position, and control and supply are facilitated. The characteristic smoke and flash of the gun are partially concealed from observation.

d. **Disadvantages.** Rapidly moving ground targets are not easily engaged because adjustment of fire must be made through an observer. Targets close to the mask usually cannot be engaged, and it is difficult to secure grazing fire for a final protective line.

e. **Position Selection.** The fire unit leader selects the location of the gun position. To select a position in partial defilade, he moves up the reverse side of the slope until he has the target in view above the mask when sighting at the height of the gunner's eye. To select a position in maximum defilade, he estimates the lowest point below the mask at which the gun can still engage the target without danger of hitting the mask.

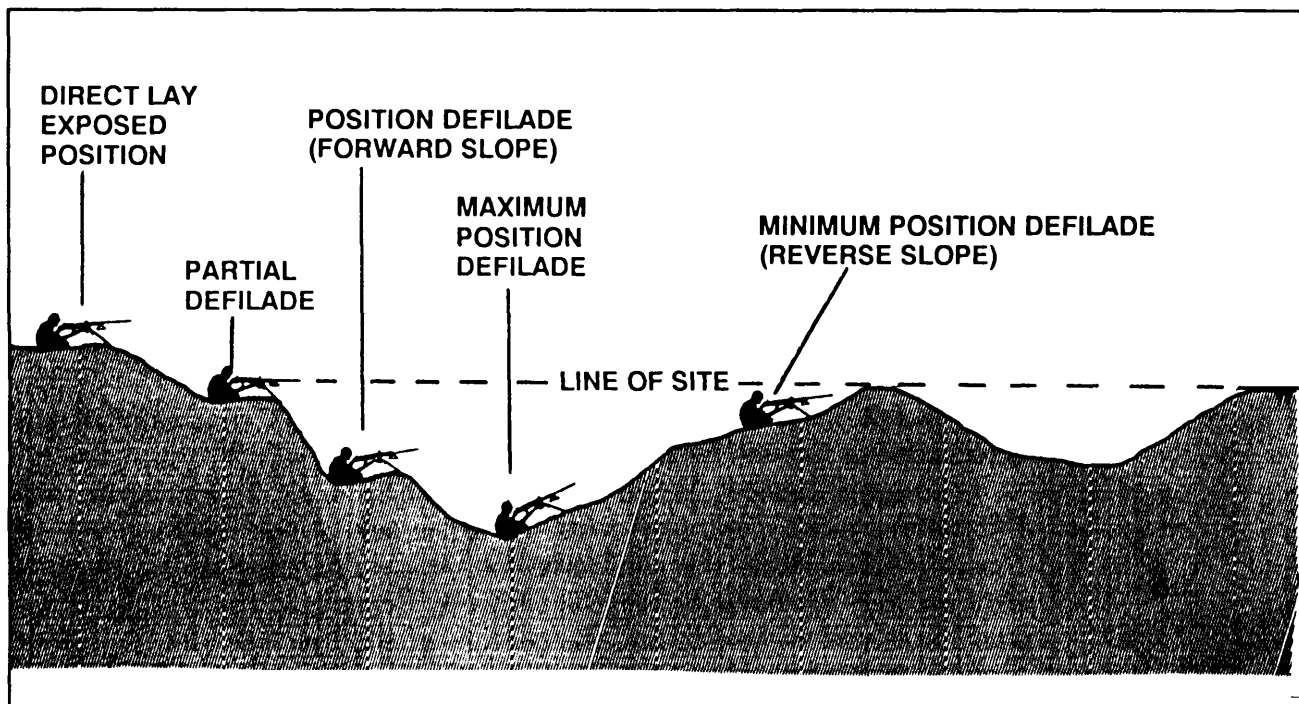

Figure 6-15. Minimum and maximum position defilade, partial defilade, and direct lay areas.

6-7. METHODS OF LAYING THE GUN FOR DEFILADE FIRING

The essential elements in engagement of a target from defilade position are direction, elevation, mask clearance, and adjustment of fire.

a. **Direction.** An observer places himself on the gun-target line in a position from which he can see the gun and the target. He aligns the gun approximately by having the gunner shift the mount. The gunner then loosens the traversing slide lock lever and, as directed by the observer, moves the gun right or left until it is aligned on the target; he then clamps it in that position. A prominent landmark, visible to the gunner through his sights, is selected as an aiming point. An aiming point on the gun-target line and at an equal or greater range than the target is desirable. However, an aiming point on the mask may be used. If the aiming point is on the gun-target line, the gun is laid on the aiming point and is thereby aligned for direction. If the aiming point is not on the gun-target line, the deflection is measured by binoculars or compass. This measured deflection is laid off with the gun.

b. **Elevation.** An aiming point visible from the gun position is selected (preferably a point at a greater range and at a higher elevation than the target) and the range to the target is determined. The leader, using binoculars, measures the vertical angle in roils from the aiming point to the base of the target. He then lays the gun on the aiming point with the sight set to hit the target. He directs the gunner to manipulate the gun through the number of mils measured. For example, in Figure 6-16, the range to the target is 1,300 meters. The angle read with the binoculars from the aiming point down to the base of the target is 12 mils. The sight is set at 1,300 meters, the gun laid on the aiming point, and the muzzle depressed 12 mils. If the aiming point is off the gun-target line, deflection in mils may be taken with the rear sight windage screw knob if it is not over 5 mils; otherwise, the deflection must be taken up on the traversing handwheel.

c. **Mask Clearance.** After the gun has been laid, determine if the entire cone of fire will clear the mask.

(1) *Visual method.* When the range to the mask is not more than 450 meters, mask clearance exists when the axis of the bore is elevated 7 mils or more above the gun-mask line. Mask clearance can be checked after the gun has been laid on the target by depressing the muzzle of the gun 2 mils and sighting along the bottom of the receiver and the barrel support. If this line of sight clears the mask, the clearance exists. Elevate 2 mils before firing.

(2) *Firing tables method.* Determine the range to the mask and obtain the corresponding angle of elevation for mask clearance from the firing

tables. The range corresponding to the angle of elevation is set on the gun sight. If the line of aim through the sight clears the mask, the clearance exists.

d. **Adjustment of Fire.** Under field conditions, even the most practical methods of laying the gun on the target quickly do not always result in the initial burst being on the target. For this reason, adjustment of fire on the target is essential. Creeping fire should be avoided. (See paragraph 6-10 for details on adjustment of fire.)

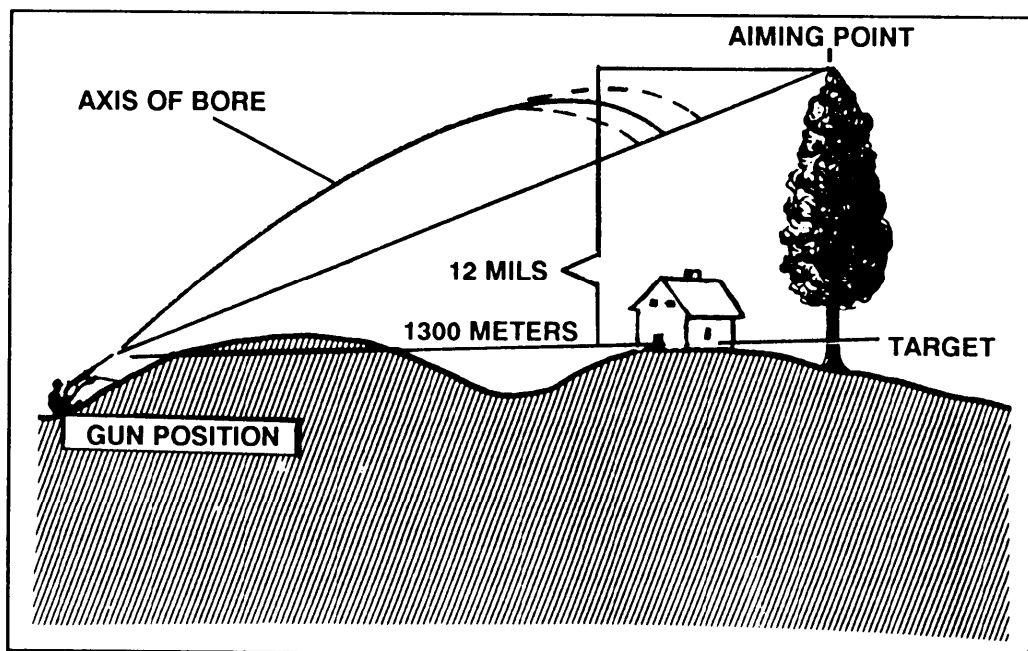

Figure 6-16. Aiming point method.

6-8. FINAL PROTECTIVE FIRES

These are types of fire that are placed on a predetermined line along which grazing fire is placed to stop an enemy assault. This fire is fixed in direction and elevation; however, a few roils of search are employed during firing to compensate for irregularities in the terrain. FPLs are always laid in using the extreme left or right of the tripod, causing the T&E to move to the extreme left or right on the traversing bar. The FPFs can be delivered in any visibility conditions. When terrain permits, final protective lines are assigned to machine guns along the forward line of troops as a part of the FPFs of the defending unit. The signal used to call for FPFs is normally prescribed in the company operation order. The

authority to call for these fires may be delegated to the platoon leader of a forward rifle platoon. Final protective fires are ceased on order.

a. **Signals.** Arm-and-hand signals, voice commands, or pyrotechnic devices may be used in calling for these fires.

b. **Rates of Fire.** When firing FPFs, the rapid rate of fire is used unless it is obvious that a different rate is necessary to accomplish the mission. When engaging other preselected target areas, the rapid rate of fire is used until commanded to cease fire.

6-9. APPLICATION OF FIRE

To be effective, machine gun fire must be distributed over the entire target area. Improper distribution of fire results in gaps which allow the enemy to escape or use weapons against friendly positions without effective opposition.

a. The method of applying fire to a target is generally the same for either a single gun or a pair of guns. Direct laying is pointing the gun for direction and elevation so that the sights are aligned directly on the target. Fire is delivered in width, depth, or in a combination of the two. To distribute fire properly, the gunners must know where to aim, how to adjust their fire, and the direction to manipulate the gun. The gunner must aim, fire, and adjust on a certain point of the target. Binoculars may be used by the leader to facilitate fire adjustment.

b. The gunner ensures throughout his firing that the center of the beaten zone is maintained at the center base of the target for maximum effect from each burst of fire. When this is done, projectiles in the upper half of the cone of fire will pass through the target if it has height, and the projectiles in the lower half of the beaten zone may ricochet into the target (Figure 6-17).

c. The gunner must move his beaten zone in a certain direction over the target. The direction depends on the type of target and whether the target is engaged with a pair of guns or a single gun. When engaging targets other than point targets with a pair of guns, the targets are divided so that fire is evenly distributed throughout the target area. Fire delivered on point targets or a specific area of other target configurations is called concentrated fire.

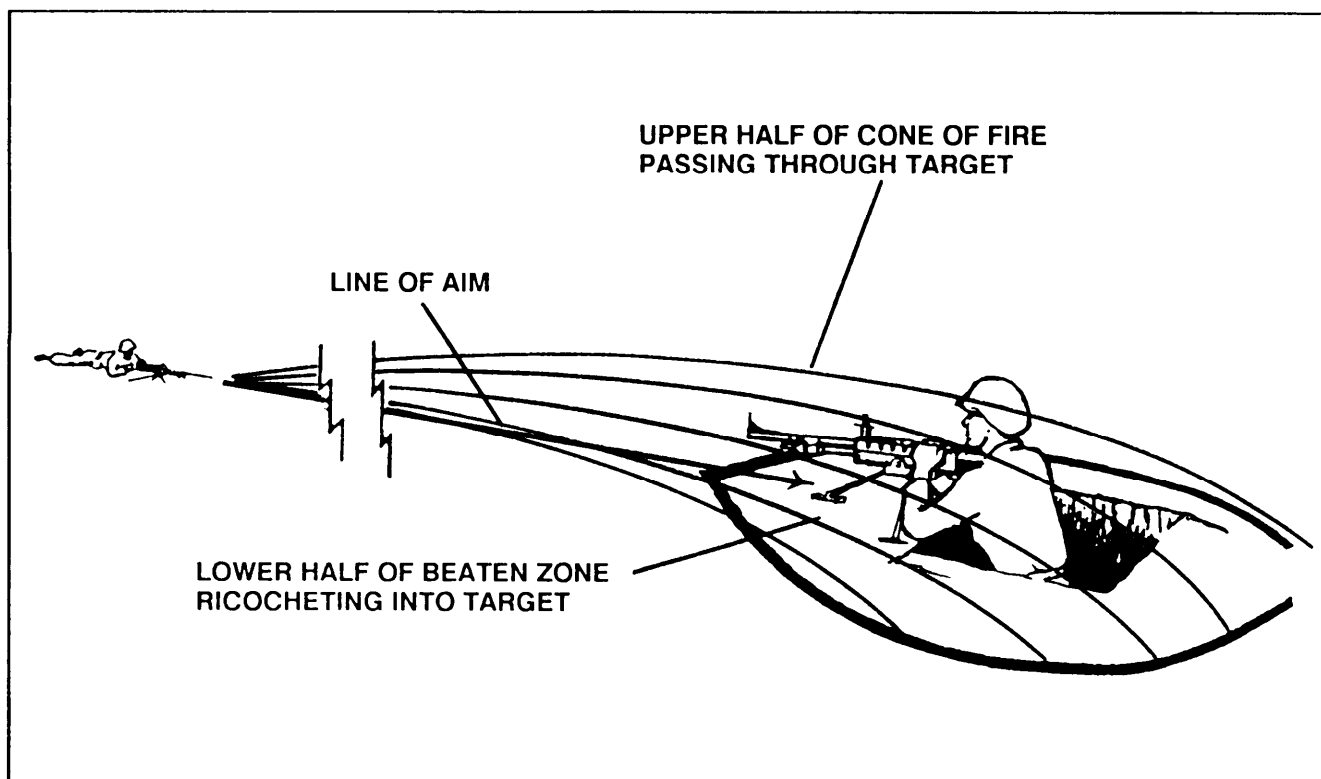

Figure 6-17. Line of aim and placement of center of beaten zone on target.

6-10. FIRE ADJUSTMENT

Machine gun fire is adjusted by observing the strike of the rounds, observing the flight of tracers, frequently re-laying the gun, or by a combination of these. Adjustment by observation of fire is the most important element of fire control if it is bold, aggressive, rapid, and continuous throughout the action.

a. The gunner is trained to observe and adjust his gun's fire without command. He is trained to anticipate the action of the enemy after the initial burst, and is prepared to shift his fire to cover any change in formation or movement of his target. If the gunner fails to accomplish this, the fire unit leader must promptly correct him by announcing or signaling subsequent fire commands. This responsibility to adjust fire continues through the chain of commands.

b. When subsequent fire commands are given, the gunner makes the required corrections and continues to engage the target without any further command to fire. If the gun is fired on the tripod mount, subsequent commands are given to make changes in direction, elevation,

and the rate of fire. These changes are given orally as SHIFT RIGHT, SHIFT LEFT, ADD, or DROP. (For arm-and-hand signals see FM 21-60.) When making these announced changes, mils may be used to indicate the amount of desired shift; for example, SHIFT RIGHT 5 or SHIFT LEFT 7. When making changes in elevation, roils are not used, as it is normally difficult to determine just how high or low the center of the beaten zone is striking the ground in relation to the target.

(1) *Observation.* When firing on the 10-meter range, the strike of the bullets is visible on the target. When firing at greater distances, the strike of the bullets on the ground may cause dust to rise, which is visible to the gunner; however, during wet weather the strike cannot always be seen. In this event, the tracers will allow the gunner or crew leader to note the strike of the burst in relation to the target.

(2) *Adjustment.* Using the mil relation, one click of the traversing handwheel or elevating handwheel moves the strike of the bullet 1/2 inch on the target at a range of 10 meters.

(a) When firing on the 10-meter range, adjust by moving the shot group a required number of centimeters vertically or horizontally until the center of the group is on the aiming paster. Should the gunner's initial burst strike the target 2 centimeters to the left and 3 centimeters below the aiming paster, he adjusts his fire by traversing right 4 clicks and elevating 6 clicks before firing again.

(b) When firing on field targets, adjust by moving the burst into the target. One click (roil) on the traversing handwheel will move the strike 1/2 meter at 500 meters or 1 meter at 1,000 meters; however, the distance 1 click (roil) in the elevating handwheel will move the strike depends on the range to the target and the slope of the ground. The gunner determines the number of roils necessary to move the center of the strike into the target, and he manipulates the gun the required number of roils. This does not require the use of sights. For example, should the gunner fire on a target at 500 meters and observe the strike 10 meters to the right of the target and short about 50 meters, he would traverse the gun to the left 20 clicks (roils) and add one or more clicks (roils), depending on the slope of the ground.

(c) The gunner may use the adjusted aiming point method to adjust the fire. In this method the gunner must use his sights. He selects an aiming point that will place the next burst on the target. For example, should the gunner fire on a target at 500 meters and estimate that the strike is 20 meters short and 10 meters to the right of the target, he would rapidly select an aiming point approximately 20 meters beyond the target and 10 meters to the left of the target, lay on that aiming point, and fire.

6-11. ANTI-AIRCRAFT GUNNERY

The MG can provide units with a self-defense capability against hostile low-flying, low-performance aircraft. These guns are employed in the air defense role as part of the unit's local defense. The MGs are not components of an integrated and coordinated air defense system. Unless otherwise directed, hostile aircraft within range of the gun (about 800 meters maximum effective range) should be engaged. The decision will be made by the commander. Typical targets are surveillance, reconnaissance, and liaison aircraft; troop carriers; helicopters; and drones.

a. **Engagement and Employment.** The mission is to impose maximum attrition upon the attacking enemy, such as low-flying, low-performance aircraft. Employment of MGs used for air defense is guided by the following defense design factors:

- Defense design should produce an equally balanced defense that is effective in all directions, unless a forced route of approach exists.
- Machine guns should be sited so that the maximum number of targets can be engaged, continuous fire can be delivered, and the most likely routes of approach are covered.
- Machine guns used to defend march columns should be interspersed in the convoy, with emphasis on the lead and rear elements (Figure 6-18).

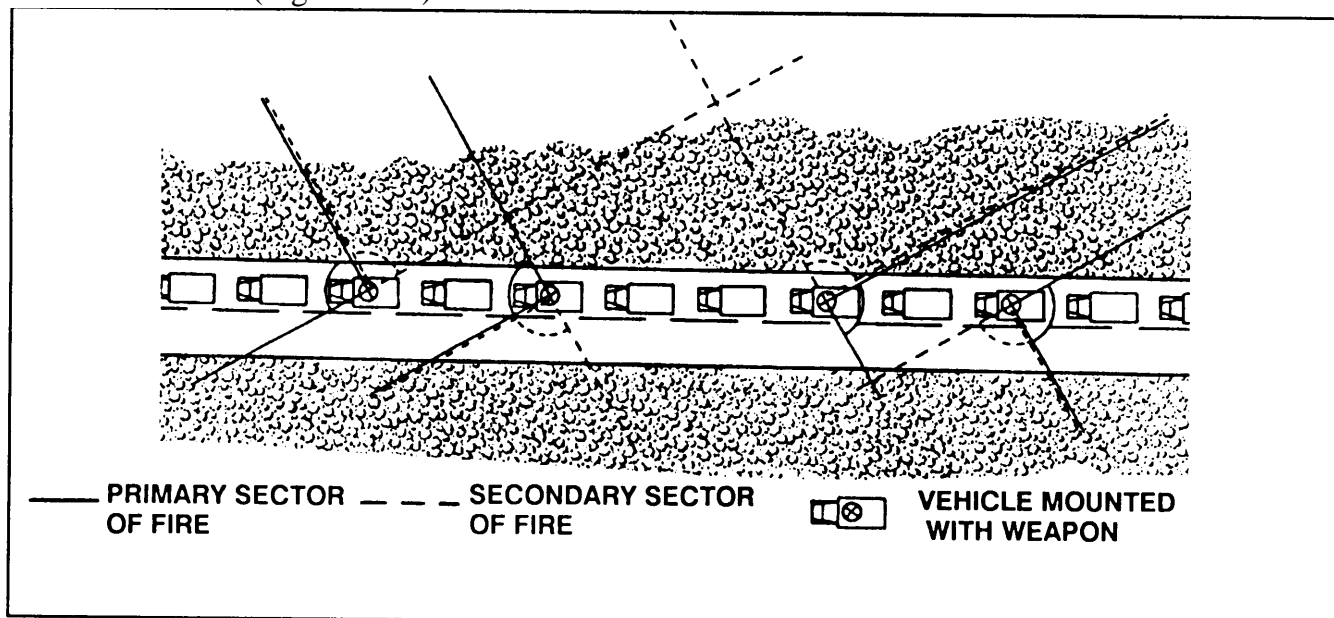

Figure 6-18. March column with four MGs (added).

b. **Target Selection and Engagement Control.** These actions depend upon visual means. The sites selected for the guns must provide maximum observation and unobstructed sectors of fire. Units furnished MGs in sufficient numbers should site them within mutual support distances of 90 to 360 meters. Each gun is assigned a primary and secondary sector of fire. Weapon crews maintain constant vigilance in their primary sectors of fire, regardless of the sector in which the guns are actually engaged.

Section III. LIMITED VISIBILITY CONDITIONS

The machine gun is provided with a stable tripod mount, M3, and a traversing and elevating mechanism. By manipulating the T&E mechanism, gun crews can record target data during good visibility and engage the same targets in poor visibility. This section provides guidance on machine gun firing techniques and terms used during limited visibility, which includes darkness, smoke, fog, rain, or snow.

6-12. DIFFICULTIES

Crewmembers encounter difficulties while defending during limited visibility, which preclude the use of many of the daylight techniques of engaging targets.

a. During limited visibility, the machine gunner's sector of responsibility cannot be observed in depth; therefore, targets are difficult or impossible to detect.

b. Visibility may be so limited that the leader cannot control the fires of his guns by selecting and directing fire on targets as he would during good visibility. Oral commands are not dependable, arm-and-hand signals may not be seen, and personal contact with the gunner is difficult.

c. At night, machine gunners have a tendency to fire indiscriminately at noises and suspected enemy locations.

To overcome these difficulties, special techniques must be developed for engaging targets and delivering preplanned fires by the use of range cards. (See Appendix E.)

6-13. TERMINOLOGY

The following terms must be familiar to MG crews for them to complete their missions in poor visibility.

a. **Sector of Fire.** An area (to be covered by fire) assigned to an individual or unit. Machine guns are normally assigned two sectors of fire, a primary and a secondary sector.

b. **Final Protective Line.** A predetermined line along which grazing fire is placed to stop an enemy assault. The FPL is fixed as to direction and elevation; however, a few roils of search are employed during firing to compensate for irregularities in the terrain. The FPL can be delivered regardless of visibility conditions. The FPL is always the inner limit of the primary sector, which is assigned close to the forward line of troops area. When terrain permits, FPLs are assigned to machine guns along the **FLOT** as a part of the final protective fires of the defending unit.

c. **Principal Direction of Fire.** A PDF is a priority direction of fire that marks a specific area assigned to a weapon. This area may extend from the gun position to the maximum effective range of the weapon and therefore is not fixed for elevation. Visible targets appearing in the PDF take priority over targets that may appear elsewhere in the sector. A PDF may be assigned to cover an area that provides good fields of fire, is a likely avenue of foot approach, or mutually supports an adjacent unit.

d. **Sector of Graze.** A wedge-shaped area formed by assigned sector limits that afford grazing fire (one meter high, maximum) from the muzzle of the weapon to the first major break in the terrain. The sector of graze is fired using swinging traverse in the primary sector of fire. It can be fired in the secondary sector in conjunction with field expedients by freeing the T&E mechanism and using the mount as a pivot. A sector of graze can be delivered regardless of the condition of visibility.

e. **Area of Graze.** This is an area, other than the sector of graze, within a sector of fire that is covered by grazing fire. Grazing fire need not be continuous from the muzzle of the weapon to the area over which grazing fire is desired.

6-14. TARGET ENGAGEMENT

A gunner's ability to detect and identify targets during limited visibility will vary, depending upon the amount of natural and artificial light and the types and numbers of sensors used. All tracer ammunition allows a gunner to more effectively engage visible targets during limited visibility; it should be used when possible. Gunners must be trained to fire low initially and adjust up when engaging targets during limited visibility. This helps them overcome the tendency to fire high during these conditions. The types of point targets machine gunners will be concerned with during limited visibility, particularly at night, are enemy automatic weapons and assaulting enemy personnel.

a. Point targets such as automatic weapons may be identified during limited visibility by their muzzle flashes. To effectively engage these

targets, fire should be delivered in a heavy volume and adjusted by observing the tracer stream.

b. During the final stage of an enemy assault, machine guns normally fire at personnel on an FPL; they may be assigned a PDF. Both are considered as final protective fires and should be planned for and coordinated as such. If individual enemy soldiers are observed in the proximity of the gun position, they must be neutralized by someone other than the machine gunner (by the other crewmembers or by security forces of the supported unit). The FPFs are fired according to the order or SOP, and the machine gunner is not allowed to stop firing them except in accordance with those orders or SOP.

6-15. FIRE CONTROL

During limited visibility, the leader cannot direct the fires of his guns as effectively as with good visibility. Consequently, initiative is required of the gunners. When targets within their sectors become visible to gunners, they must engage such targets without command and continue to fire until the targets have been neutralized. Gun crews engage targets only when they can identify them, unless ordered to do otherwise. For example, if one gunner detects a target and engages it, the other gunners will observe the area in which fire is being placed. They will add their fire only if they can identify the target or are ordered to place fire in the area.

6-16. PREPLANNED FIRES

In addition to engaging appropriate visible targets, the gunner must be able to deliver preplanned fires during limited visibility. These fires are used to cover target areas of tactical significance (such as routes, avenues of approach, anticipated enemy supporting weapons positions, and probable enemy assault positions) and to establish sectors of graze and final protective lines. For maximum effect in all preplanned target areas, grazing fire should be obtained when possible.

a. **Obtaining Maximum Extent of Grazing Fire Over Level or Uniformly Sloping Terrain.** The machine gunner sets the rear sights at 700 meters; selects a point on the ground, which he determines to be at a range of about 700 meters; and lays, fires, and adjusts on this point. If the gunner cannot obtain 700 meters of grazing fire because of a major break in the ground at a range of less than 700 meters, he places the range to the break on his sight and lays, fires, and adjusts at that point.

b. **Determining the Extent of Grazing Fire on the Final Protective Line.** The extent of grazing fire on the FPL is determined using the techniques described above. Any intermediate breaks in the terrain along

this line that cannot be covered by grazing fire from a gun firing along the line is considered dead space.

c. **Determining the Extent of Grazing Fire in the Sector of Graze.** The ranges to the extent of grazing fire in a sector of graze are determined by observing the terrain and by observing the tracer stream from behind or from a flank of the gun position. Normally, the extent of grazing fire within this area will be much less than on an FPL and will form an irregular pattern.

d. **Determining the Amount of Grazing Fire in an Area of Graze.** The same procedures used in paragraph 6-8a are used in determining the extent of grazing fire in an area of graze. The ranges to areas of grazing fire are determined by observing the flight of tracer ammunition from behind or from the flank of the gun position. The gunner determines the lateral extent of areas of graze by selecting and engaging successive aiming points in the area believed to afford grazing fire, using the same range setting as when determining the range to the extent of grazing fire.

6-17. NBC CONSIDERATIONS

During this phase of training, the gunner is introduced to firing the machine gun while in MOPP, keeping in mind that engagement of some targets in MOPP is a qualification requirement. Firing weapons is only part of the overall NBC training. Soldiers must first be familiar with the NBC equipment, its use, and proper wear before they progress to learning the techniques of MOPP firing. Although there is no different technique required to fire the MG, there are certain fundamentals that may be slightly impaired.

a. **Immediate Action.** Under normal conditions, a gunner should be able to clear a stoppage in two to four seconds; however, under full MOPP, this may take a few seconds longer. Dry-fire practice under these conditions is necessary to reduce time and streamline actions. When practicing with the hood/mask and gloves, care must be taken not to snag or damage the gloves or dislodge the hood/mask during movement. Trainers should apply immediate action to a variety of stoppages during dry fire until the gunners are able to instinctively do it without compromising their NBC environment.

b. **Target Detection.** Techniques and principles of target detection and target acquisition still remain valid during NBC conditions, but considerations must be made for limiting factors imposed by MOPP equipment. For example, vision is limited to what can be seen through the mask's lens/faceplate. Peripheral vision is severely restricted. The lens/faceplate may be scratched or partly fogged, thus further restricting

vision. Gunners requiring corrective lenses must be issued insert lenses before training. Scanning movements may be restricted by the hood/mask. Any of these factors could adversely affect the gunner's ability to quickly and accurately detect targets. Extra skill practice should be conducted.

c. **Efficient Performance.** The trainer must keep in mind that although movements are slowed, tasks take longer, and function checks, loading, unloading, and cleaning are affected by MOPP, it is a must that the gunner avoid damaging MOPP gear and risk possible exposure to lethal agents. Because of the great difference between no MOPP and MOPP4, gunners must be trained in all aspects of operation and maintenance of the weapon while practicing at the highest MOPP level. Only through repeated training and practice can the soldier be expected to perform all tasks efficiently.

CHAPTER 7

TRAIN THE TRAINER PROGRAM

The information in this chapter tells how to train the trainer, how to advise the trainer, and how to assist the trainer in preparing the crew for the three phases of MG marksmanship.

7-1. CONCEPT

The Train The Trainer Program must be planned properly and conclude with a certification program. In the planning phase, the instructor teaches the trainer to be flexible and thorough. He must plan alternate exercises in case weather or other constraints prohibit the originally scheduled training. Training must not follow rigid timetables that inhibit training and learning; instead, schedules should be established that provide sufficient time to correct mistakes and ensure learning. The following are factors that the trainers are taught to consider:

a. **Support.** Training requires support. The trainers must ensure that the training is conducted within the resource levels and that the training received justifies the material used. Public address systems should be used if the group is larger than a platoon-size element.

b. **Time.** Ample time must be allocated for each phase.

c. **Participants.** Trainers must consider whether or not the groups or individuals to be trained are capable of benefiting from the phases selected. (See paragraph 7-2a.)

d. **Safety.** Safety is the most important factor and therefore will be the main consideration. Trainers as well as the personnel to be trained will ensure all safety precautions are met. Anyone observing any unsafe act will immediately call CEASE FIRE or HALT to any training. A good way to emphasize safety is to give the students a test on the procedures. An example of a written examination on safety is shown in Figure 7-1, page 7-2.

SAFETY REQUIREMENT EXAM		
INSTRUCTIONS: Mark each answer as being true or false.		
T	F	
	✓	1. Firing can be done without a safety officer.
	✓	2. Firing can be done without correct headspace.
	✓	3. Firing can be done without correct timing.
✓		4. No gun should be loaded until the command to do so.
✓		5. Each gun is cleared and checked after it is fired.
✓		6.No one is allowed in front of the gun for any reason unless authorized by the OIC/NCOIC.
	✓	7. Guns can be fired outside safety areas.
	✓	8. Guns can be pointed at other personnel while clearing them.
✓		9. Firing stops immediately upon the command CEASE FIRE.
✓		10. Personnel will stay in designated safety areas until the command is given to leave by OIC/NCOIC.
Answer key: 1. F; 2. F; 3. F; 4. T; 5. T; 6. T; 7. F; 8. F; 9. T; 10. T.		

Figure 7-1. Safety examination.

7-2. TRAINER CERTIFICATION PROGRAM

The Trainer Certification Program is designed to build pride, confidence, and overall working/teaching knowledge of the functions, employment, and overall training of the MG. The trainer must know how to do all the tasks he is going to be teaching; the certification program determines his capability to do this. The program is conducted in three phases.

a. **Phase I: Basic Fundamentals of Marksmanship.** In this phase the instructor must ensure the trainers being trained perform dry fire techniques; prepare firing positions, fighting positions, and range cards; and manipulate the T&E mechanism. At the end of this phase, they will be given a hands-on examination to test their basic knowledge. This test may be developed by the OIC/NCOIC of the MG committee.

b. **Phase II: Basic Marksmanship.** In this phase, the trainer moves one step closer to becoming a skilled gunner. He must learn the correct procedures to zero the weapon; he must master the 10-meter target paster; and once this is accomplished, he must be able to engage targets on a transition range. He must show his mastery in this phase by engaging

targets at different ranges. Upon completion, the trainer is ready to move to the advanced stage of marksmanship.

c. **Phase III. Advanced Gunnery.** This is the final phase that the trainer has to achieve to standard.

(1) First, he must understand the procedures using the techniques of advanced gunnery.

(2) He must then learn tracking, which consists of maintaining correct alignment of the sights on a moving target by moving the gun at the same angular speed as that of the target.

(3) He will learn fire distribution next, which means he must be able to distribute fire over the entire target area.

(4) The last stage the trainer must learn is the correct assault fire techniques. During this stage, the gunner will normally fire on an FPL after the enemy has assaulted. He may also be given a PDF to fire at. Another assault method the trainer learns is to fire the weapon while it is mounted on a moving M113.

d. **Recertification Program.** All MG instructors are required to be recertified on a semi-annual basis. This will consist of the trainer being required to present a selected period of instruction within the current POI. The selection will be made by the CDR/OIC/NCOIC.

NOTE: Documentation of the results of the Trainer Recertification Program and the requirements must be maintained on file.

7-3. RESPONSIBILITIES AND DUTIES OF THE TRAINER

The trainer must be present during the planning and during any instruction given. The success of the preparation and instruction of all training depends upon the thoroughness with which the trainer performs the following duties:

- He must assist the gunner in targeting the MG.
- He should require the gunner to inspect his equipment and MG.
- He should explain and require the gunner to explain the exercise that he is about to perform.
- He should ensure the gunner's sight picture is accurate.
- He must observe the gunner's position, grip, and manipulation during any firing.
- He must show the gunner how to adjust his fire by observation.
- He must point out errors and explain their effect on the exercise.

NOTE: Safety is a must during the entire certification program. The OICs/NCOICs must ensure that no unsafe acts are tolerated.

APPENDIX A

SAFETY

Safety precautions must be observed during all marksmanship training. This appendix recommends safety precautions for the ranges described in this manual. Range safety requirements will vary with the different courses of fire.

A-1. TRAINING RANGES

The following safety precautions will be observed when using any training range.

- a. A red flag will be displayed at the entrance or in some other prominent location on the range during firing.
- b. Firing limits will be marked with red and white striped poles visible to all firers.
- c. Firing lanes must be clearly marked for easy identification.
- d. All communication equipment, such as microphones, PA systems, loudspeakers, and radios, must be in good working condition.
- e. When not in use, all MGs will be kept in a prescribed area with proper safeguards.
- f. No smoking will be permitted near ammunition, explosives, or flammables. Fire fighting equipment must be installed in ammunition shed/area.
- g. Hearing protection devices will be worn by all personnel during firing.
- h. Obstructions will never be placed in the muzzles of guns about to be fired.
- i. Always assume that guns are loaded until they have been thoroughly examined and found to contain no ammunition.

A-2. RANGE PROCEDURES

Safety requirements must be followed by all personnel on the range before, during, and after firing. It is the responsibility of the safety officer, OIC, and safety NCO to ensure all procedures are met. They are as follows:

a. **Before Firing.**

- (1) All prescribed roadblocks and barriers will be closed and necessary guards posted.

(2) All guns will be checked to ensure that they are clear of ammunition and obstructions, and that the covers are up to show they are cleared.

(3) All individuals will be briefed on the firing limits of the range and firing lanes.

(4) Range clearance will be obtained from the installation range-control office.

(5) The downrange area will be checked before firing to ensure that all personnel and equipment are clear of the area.

(6) A complete first aid kit will be on the range.

(7) Medical personnel will be located on the range or nearby where they can be contacted quickly.

(8) All guns will be checked by an officer or NCO to ensure that they are operational.

(9) Guns will not be handled except on command from the tower operator or OIC.

(10) Ammunition will be drawn and issued only on command of the OIC. When two or more lots of ammunition are used for firing, the OIC must ensure that the lots are separated and properly identified so that identification can be made by lot numbers in case of an accident or malfunction. Also, retain original packaging for possible repacking of ammunition.

(11) All ammunition must be protected from the rays of the sun. Do not put oil on ammunition.

(12) No one will move forward of the firing line without permission of the tower operator, safety officer, or OIC.

b. During Firing.

(1) Should an unsafe condition be noted, the person noting the condition will immediately call CEASE FIRE. Firing will not resume until directed by the OIC.

(2) All personnel must be aware of the danger in moving forward of the firing line to score their targets. Before the firing line is cleared and anyone is allowed forward, all machine guns will be cleared by the OIC or the safety officer.

(3) In the event of a runaway gun, keep the barrel pointed downrange. Do not unlatch the cover.

c. During Darkness.

(1) The downrange area will be checked before firing to ensure that all personnel and equipment are clear of the area. This will be done by asking three times over a public address system, IS THERE ANYONE DOWNRANGE?, pausing each time long enough to permit a response.

(2) A blinking red light must be used in addition to the red flag. It should be displayed at the entrance to the range or at some other prominent location.

(3) Two red lights will be remounted on the striped poles marking the limits of fire. They must be visible to all firers.

(4) No one will move from his position until told to do so by the OIC.

d. After Firing.

(1) Safety personnel will inspect all guns to ensure that they are clear. All guns on the firing line will be rodded whether they were fired or not. A check will be conducted to determine if any brass, links, or live ammunition is in possession of the troops.

(2) When guns have been cleared, they will be kept in a prescribed area with the bolt lock to the rear, and the feed cover raised.

A-3. WEAPONS MAINTENANCE

Before disassembly can be conducted, the gun must be cleared as discussed in Chapter 1.

a. Make sure the bolt is forward before removing the backplate assembly.

b. Never attempt to cock the gun while the backplate is off and the driving spring assembly is in place. If the backplate is off and the driving spring assembly is compressed, the retaining pin on the driving spring rod can slip from its seat in the sideplate and could cause serious injury to anyone behind the gun.

c. When lifting the receiver, barrel, or the tripod, hold it with a firm grip to avoid dropping it and possibly injuring someone.

APPENDIX B

TRAINING AIDS AND DEVICES

The use of devices in marksmanship training programs are important factors because they may allow the gunner to get an idea of what actual combat is like. The training devices designed for the MG are the M19 blank firing attachment, the multiple integrated liner engagement system, the sighting bar, and the M3 recoil amplifier barrel used with plastic ammunition.

B-1. BLANK FIRING ATTACHMENT

The M19 BFA was developed to permit the MG to fire the M1A1 blank cartridge in the automatic fire mode. The BFA is an easy to install, reliable device that allows the MG to be used more realistically during an FTX. The M19 BFA weighs 15.5 pounds and can be installed using either a crescent wrench or the blank/live round discriminator (a component of the BFA that has been designed to serve as a wrench). The design of the M19 will not allow a live round to be loaded while the blank/live round discriminator cover is in position. Normal headspace and timing must be made when firing blank rounds using the M19 (Figure B-1).

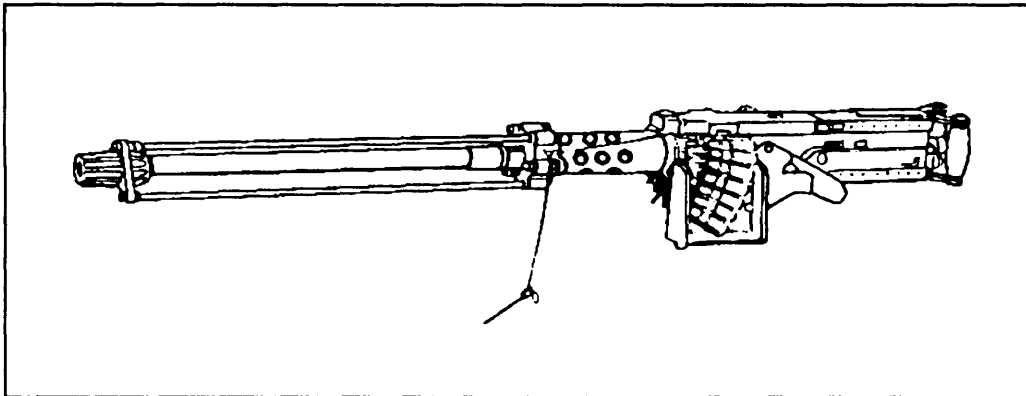

Figure B-1. M19 BFA mounted on MG.

WARNING

The flash of the M1A1 round fired with the M19 BFA at night is extremely bright. It could cause temporary night blindness, and night vision devices may be temporarily disabled.

B-2. MULTIPLE INTEGRATED LASER ENGAGEMENT SYSTEM

The MILES transmitter has been developed for the MG as well as for many other weapons. It consists of a lightweight laser transmitter that sends coded hit/kill messages whenever blank rounds are fired. The MILES transmitter is normally used as part of an M113 APC MILES kit; however, it can also be used on truck- or ground-mounted machine guns with modifications of the detector straps and the combat vehicle kill indicator (CVKI) light (Figure B-2).

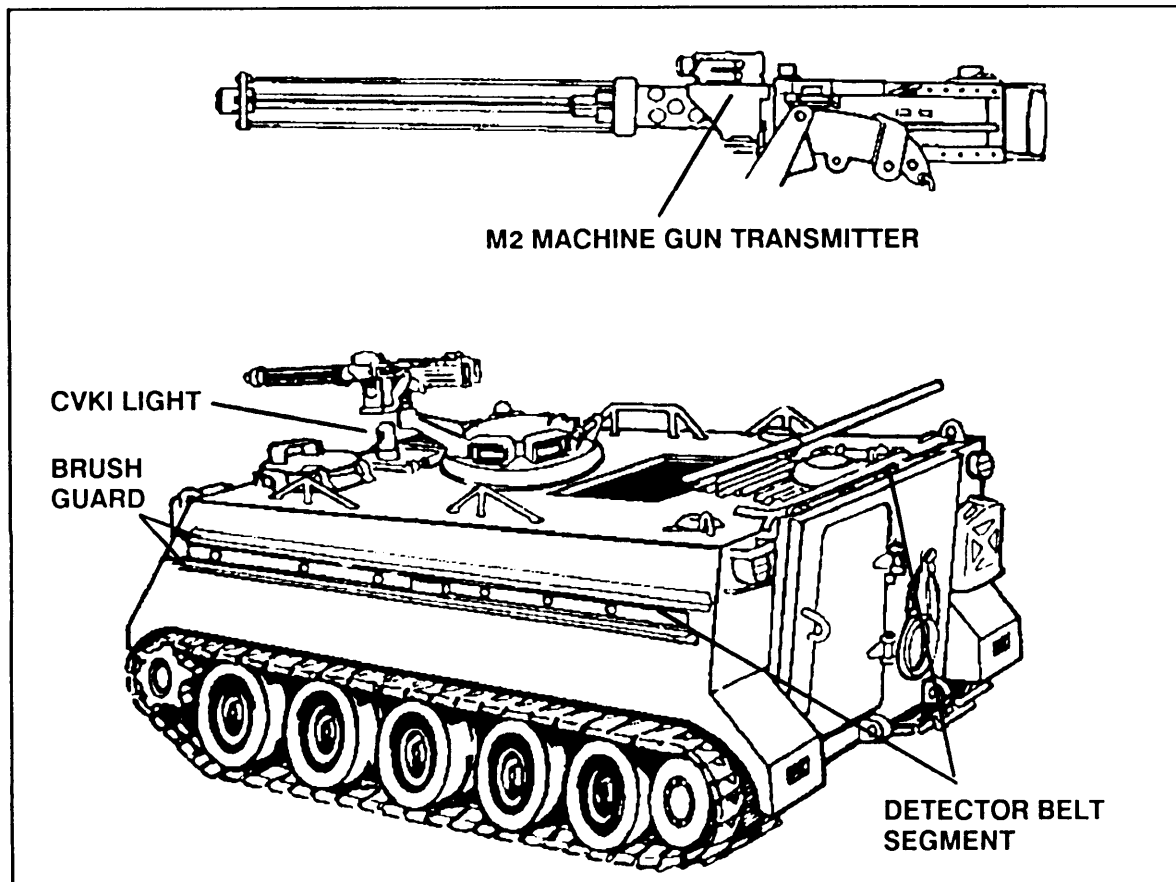

Figure B-2. Components of the M113 APC MILES kit.

a. Inspecting and Servicing the MILES Transmitter. Remove any dirt or oil from the lens using lens paper or a soft, dry cloth. Take care not to scratch the lens. Inspect the foam microphone cover; if it is wet or caked with dirt or blank firing residue, clean or replace it. Inspect the transmitter for indications of damage that would prevent normal operations (Figure B-3). Clean all surfaces. Ensure that the orange key is present. Use DA Form 2404 to report any damage to the transmitter.

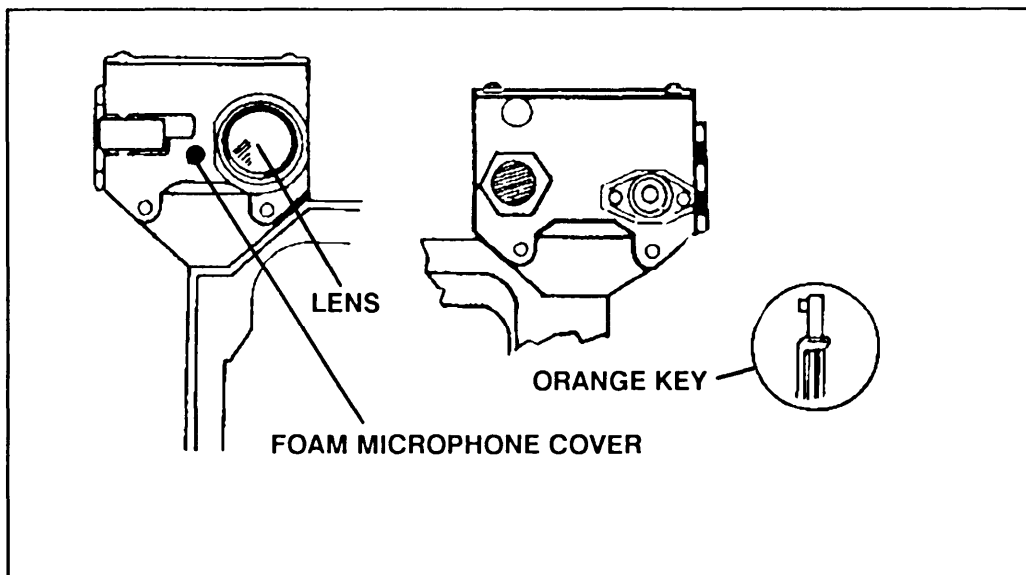

Figure B-3. Inspection of the MILES transmitter.

b. **Placing the Battery into the Transmitter.** Use the correct battery (NSN 6135-01-063-1978, BA 3090/U, 9V, alkaline); it will last about 100 hours. Flip open the latch; open the battery door and insert the battery; press the door closed; then press the latch closed (Figure B-4).

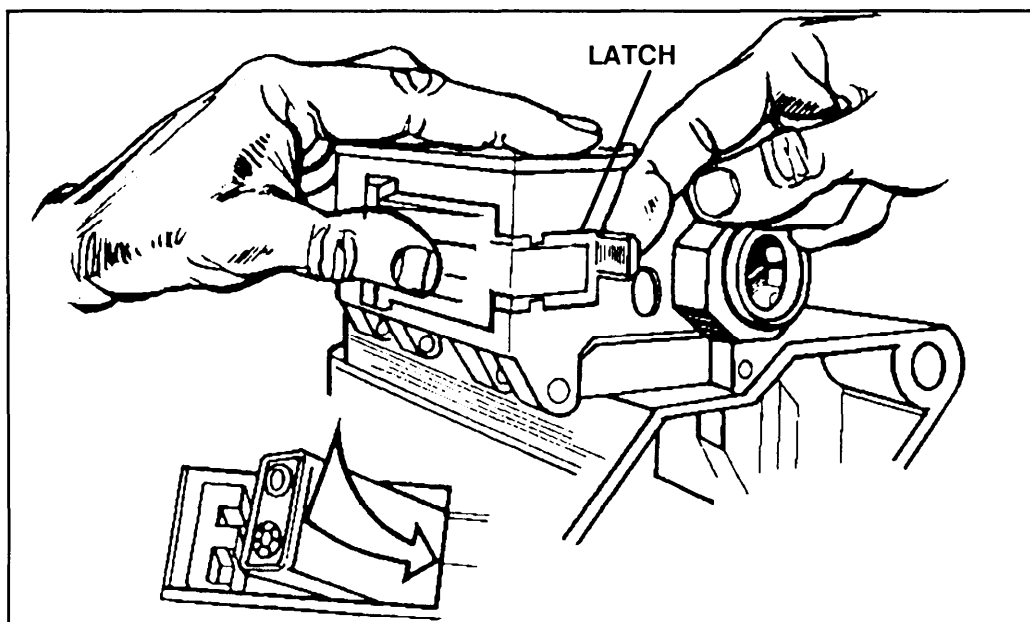

Figure B-4. Battery insertion.

c. **Attaching the Transmitter to the Machine Gun.** Attach the machine gun to its mount. Attach the M19 BFA to the machine gun. Unscrew the knob from the side of the transmitter bracket; swing the bottom plate down; and place the transmitter on the barrel support, flush against the receiver. The lip on the back of the mounting bracket must sit behind the barrel cooling bracket. Swing the bottom plate back up against the transmitter mounting bracket and tighten the knob securely with your hand (Figure B-5).

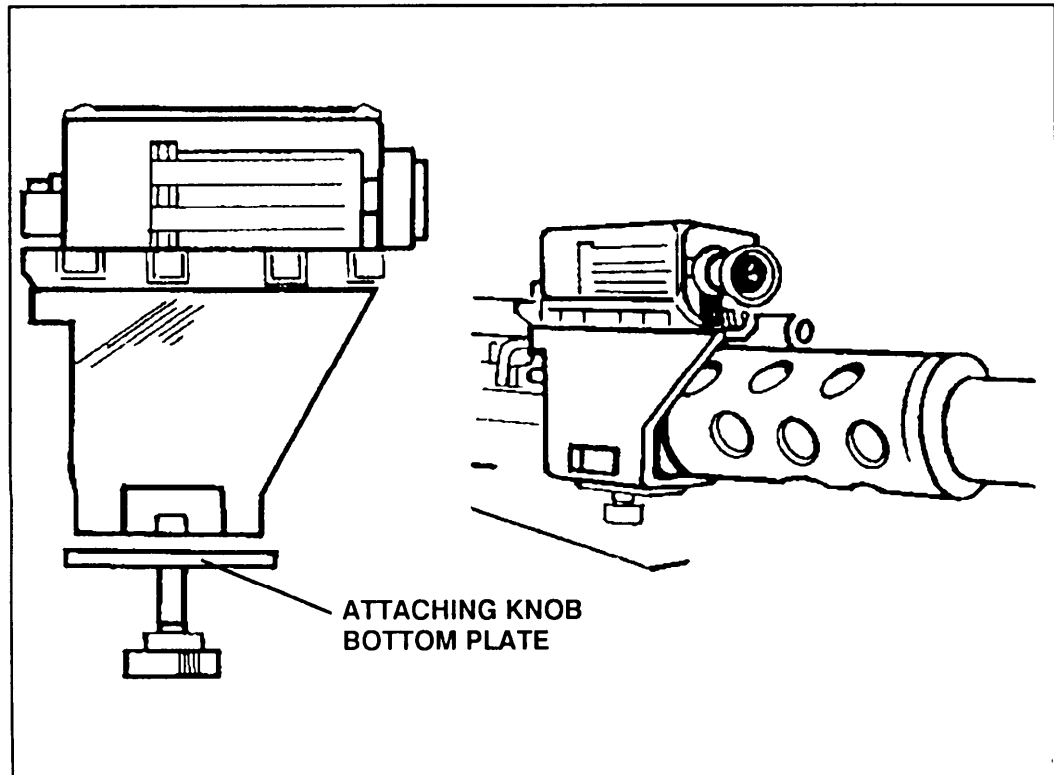

Figure B-5. MILES transmitter attachment.

d. **Operating the Transmitter.** Ensure that the M19 BFA is correctly mounted. Turn the orange key to WEAPON ON. Load the machine gun with M1A1 blank ammunition only (Figure B-6). Fire normally. The sound of the blanks firing will trigger the transmitter. The transmitter will work only as long as the supply of blank ammunition lasts. Once a day, use a clean cloth to remove blank fire residue from the transmitter lens. To test the transmitter, fire a shot burst and watch the firing lamp (Figure B-7). If no light, replace the battery and test again. If still no light, replace the transmitter. Use DA Form 2404 to report the information.

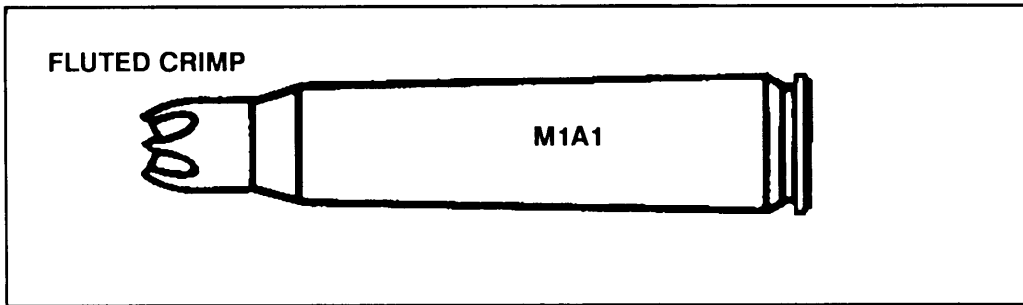

Figure B-6. Proper blank ammunition to use with M19 BFA.

WARNING
Do not use ball ammunition or M1 blank ammunition with the BFA. Use only M1A1 blanks with the fluted, crimped case mouth.

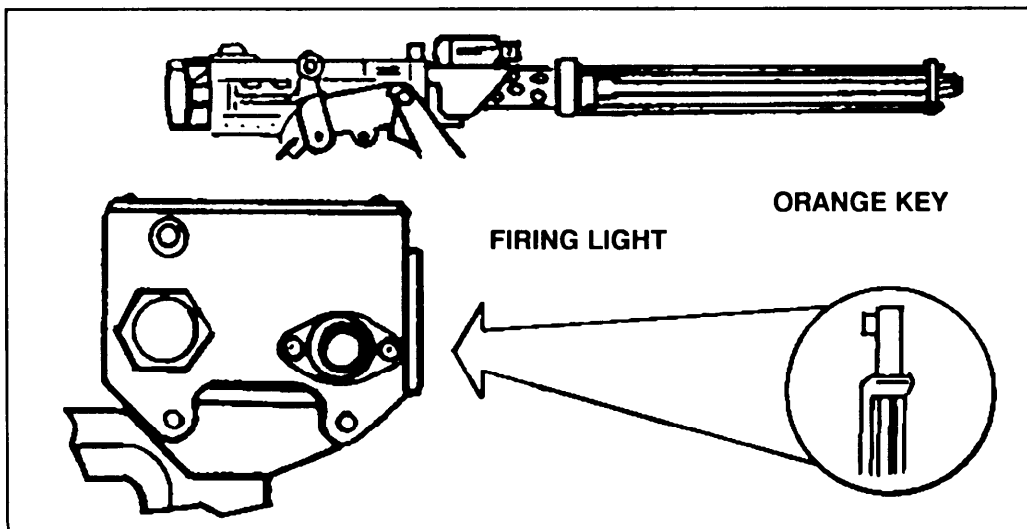

Figure B-7. Operation of the MILES transmitter.

e. **Aligning the Transmitter to the Machine Gun.** The transmitter must be aligned in the dry fire mode, using the dry fire trigger cable. To align the transmitter, you need a soldier wearing a MILES helmet and torso harness. The gun should already be mounted on a tripod and have the T&E attached.

(1) Position the soldier 50 to 75 meters away from the machine gun. Have him place a green controller key in his MILES receptacle and turn the key to the CONTROLLER position.

(2) Connect the trigger cable assembly to the receptacle on the rear of the MILES transmitter. Use the controller key to reset the system.

(3) Insert an orange weapon key into the transmitter receptacle and turn to WEAPON ON.

(4) Fire at the soldier by pressing the trigger cable button. Traverse the gun left and right, up and down, until the soldier's buzzer signals a "near miss." Hold the gun in that position.

(5) While he is being fired on, have the soldier move to his right until his buzzer stops. Have him mark that location.

(6) Have the soldier move to his left until the buzzer stops again. Have him mark that location.

(7) Have the soldier estimate the center between the two marks, and stand there.

(8) Cease fire. Without moving the barrel of the machine gun, adjust the sights until the soldier is seen through the rear sight aperture.

(9) Begin firing again and move the barrel up and down, noticing where the buzzer stops. Estimate the center of this up and down area and adjust the sight elevation to that point.

(10) Remove the trigger cable assembly and screw the protective cover onto the transmitter receptacle.

f. **Resetting the Transmitter After a Kill.** Remove the orange key from the transmitter. Use it to silence the "kill" indicator and the CVKI light. The transmitter will not fire with the key removed. When the controller resets the "kill" indicator, turn the transmitter to WEAPON ON and reinsert the orange key. Continue the mission.

g. **Using Precautions.** The following safety considerations apply to the M1A1 blank cartridge:

(1) Never fire blanks directly at personnel within 20 meters of the gun.

(2) Never fire blanks without wearing hearing protection.

(3) Never fire blanks when the temperature is below 0 degrees or above 120 degrees Fahrenheit.

(4) Never stand directly to the side of the weapon muzzle when blanks are fired.

(6) Never fire blanks in bursts in excess of 20 rounds.

(7) Always allow a cooling period between bursts to avoid overheating the gun.

B-3. SIGHTING BAR

The sighting bar is a locally fabricated device used for practicing the sighting and aiming exercise (Figure B-8). Paragraph 5-9 explains its use. This exercise requires the soldiers to look through the peephole and center on the front sight blade. The gunner adjusts the peephole until he is able to align the front sight blade in the center of it. The instructor will

then review and critique the gunner on sight alignment. The device is also equipped with a scaled target for practicing sight picture. Once sight alignment is mastered, the gunner will be required to show a correct sight picture. This is done by adjusting the scaled target until the front sight plate is bottom center of it. Again the instructor will review and critique the gunner. This exercise will continue until the gunner has mastered the technique of sighting and aiming; this requires a lot of practice.

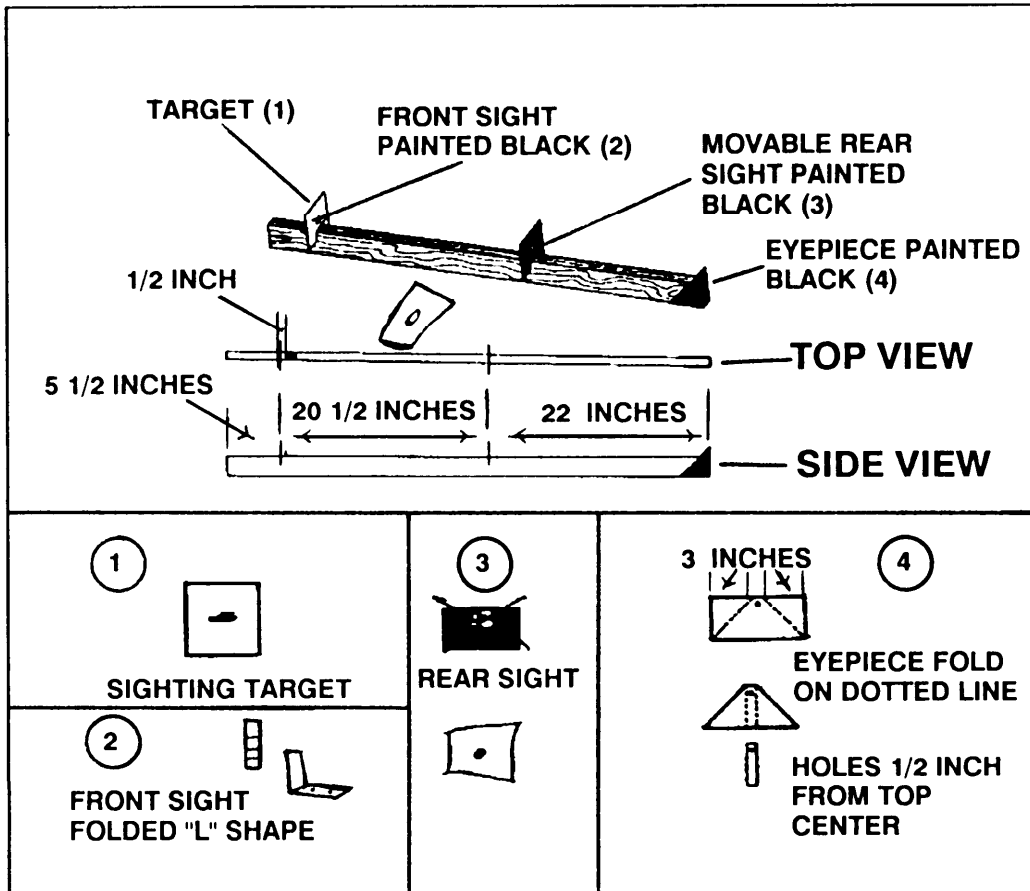

Figure B-8. Sighting bar.

B-4. SHORT RANGE TRAINING AMMUNITION

To augment the use of the caliber .50 ammunition, a new generation of SRTA (the M858 ball and the M860 tracer) has been developed.

a. The caliber .50 ball and tracer cartridges have configurations and dimensions similar to those of the corresponding service rounds; however, the base of the cartridge, which encloses the primer, is made of aluminum. The rest of the case is made of a blue-colored plastic material. The tip of

the tracer projectile is colored red. The complete round weighs about 1.05 ounces and is 5.19 inches long, which is slightly shorter than the service round. The cartridges are linked with M9-type metallic links for use with the MG. Muzzle velocity of the projectile is about 4,000 feet per second. The light weight of the projectile, about 50 grains, and its low sectional density cause its velocity to drop rapidly.

b. The SRTA allows training in small local training areas without fixed training facilities, in MOUT facilities, and in combat training theaters. With its 150-meter usable range, the SRTA can be used on grouping, zeroing, and 10-meter scaled silhouette firing.

WARNING

The SRTA projectile causes considerable damage out to 150 meters and is considered dangerous out to its maximum range of 700 meters.

B-5. M3 RECOIL AMPLIFIER BARREL ASSEMBLY

An M3 RABA (Figure B-9) is used with the machine gun for firing the training ammunition. It is assembled to the gun in the same manner as the standard barrel. The RABA provides the means to boost the power that is required to recoil the barrel and effectively cycle the weapon when relatively underpowered M858 SRTA or M860 SRTA-T are fired in the machine gun.

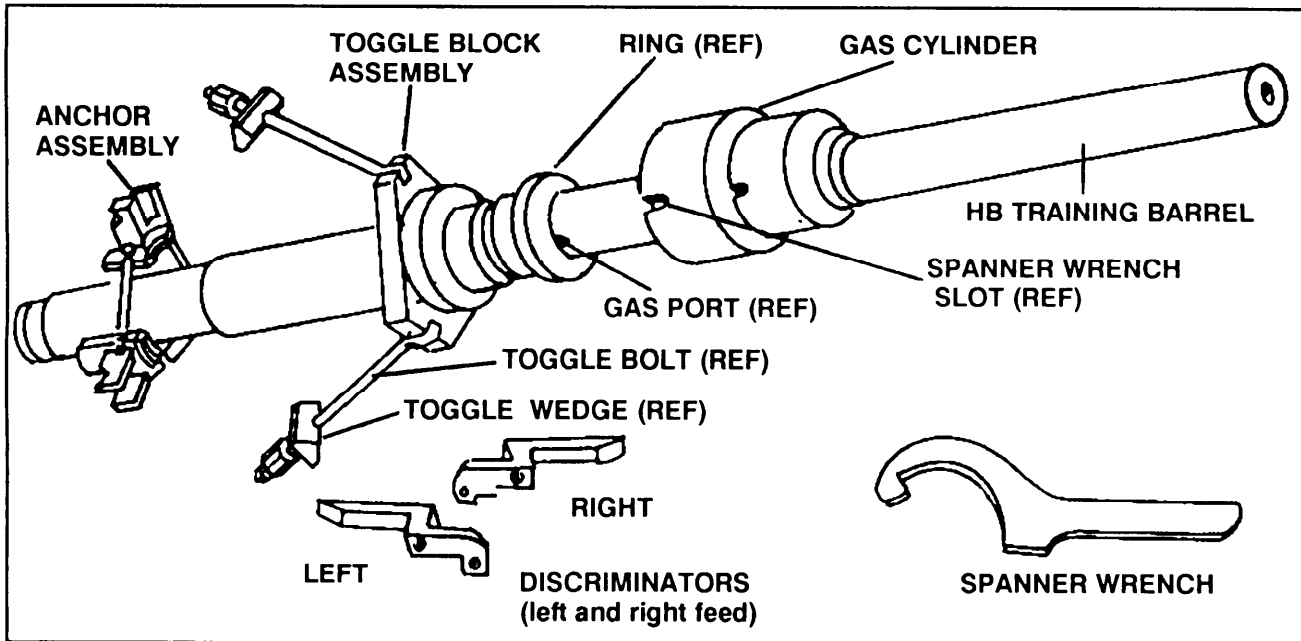

Figure B-9. M3 RABA.

APPENDIX C

RANGES AND TRAINING EXERCISES

This appendix provides guidance for US Army machine gun exercises. It is designed to be a working guide for trainers and commanders by explaining range layouts, conduct of firing exercises, and qualification standards. The two basic firing ranges will be the multipurpose MG transition range and the multipurpose range complex

Section I. MULTIPURPOSE MACHINE GUN TRANSITION RANGE

All machine gun firing can be conducted on the multipurpose MG transition range. It allows for complete firing of the 10-meter course as well as transition, day, night, and NBC firing. The firing area has 10 lanes; its layout is shown in Figure C-1, page C-2. Details on the setup and target configuration are described in FM 25-7. The minimum personnel required to operate the range are as follows: OIC, NCOIC, safety officer, ammunition NCO, tower operator, lane NCOs, primary instructor, and concurrent training instructors. Local policy may require more personnel.

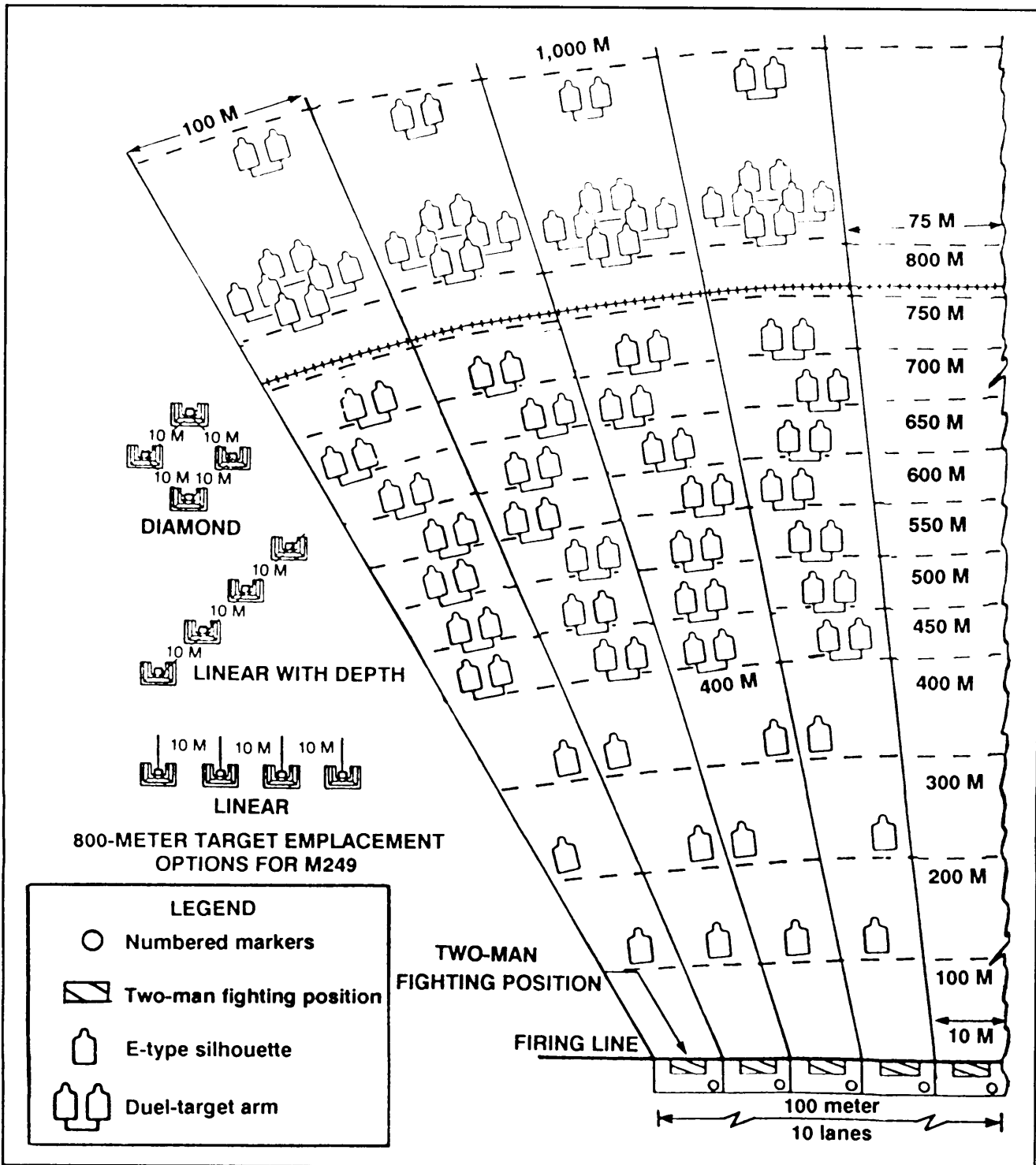

Figure C-1. Multipurpose MG transition range layout.

C-1. TEN-METER RANGE LAYOUT

The standard, basic 10-meter range can accommodate a unit of 200 to 250 soldiers at a time; however, concurrent training may be required. This range (Figure C-2) can be used to zero the M249, M60, and M2 machine guns, and to fire the 10-meter portion of qualification. It is also used to familiarize soldiers with the characteristics, noise, and recoil of the weapon. This is the range used to practice target observation and adjustment of fire, to practice MG traversing and searching, to develop speed during operation, and to obtain an accurate burst.

a. **Characteristics.** The following data applies to the standard 10-meter range.

- Number of firing positions20 lanes.
- Firing lane width60 meters (3 meters per lane).
- Target area width60 meters at the farthest targets (10 meters).
- Firing point configurationNumbered markers on slightly elevated and sodded ground; brass deflectors between lanes.
- Target configurationStandard 10-meter machine gun target stretched over a wooden frame, one on each lane.
- Associated facilitiesStandard facilities, public address system, and bleachers.

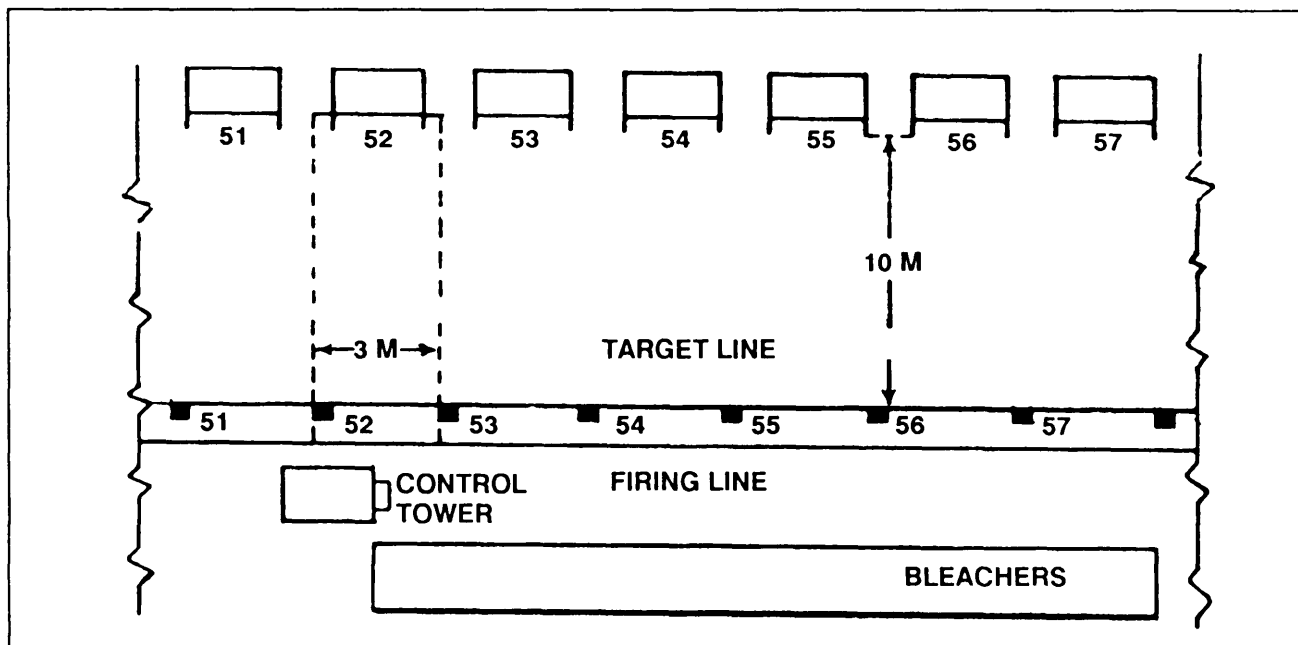

Figure C-2. Ten-meter range layout.

b. **Setup of Range.** The 10-meter range should meet the following requirements:

(1) The firing line should be long enough to emplace 20 MGs, allowing 3 meters between positions. For control, each position should be numbered.

(2) The target line should be 10 meters in front of the firing line. The MG marksmanship target is a paper target pasted onto target cloth that is stretched over a wooden frame. One target is set up for each position and is numbered to correspond with the numbered position.

(3) The instruction site for this range is the bleachers, which should be to the rear of the firing line.

(4) The control tower is located to the immediate rear and center of the firing line.

c. **Personnel Required.** Each range must be staffed with the following personnel:

- One officer in charge.
- Ž One safety officer.
- Ž One principal instructor.
- One assistant instructor for every 10 students.
- One ammunition NCO.
- One tower operator.
- Medical personnel.

d. **Equipment Required.** Although more equipment may be required by local range regulations, safety regulations, or unit SOPs, the minimum equipment required to operate the range is as follows:

- One public address system.
- One MG for each firing lane and one extra gun for every five lanes as a backup.
- One cleaning rod per assistant instructor.
- Ž One scorecard per soldier.
- Ž One asbestos glove for every two weapons.
- Ž One M3 tripod for each lane.
- One caliber .50 pintle for each lane.
- Ž One caliber .50 T&E mechanism for each lane.
- Medical evacuation capability.
- Communication equipment (wire or radio as required to operate the range).

C-2. TEN-METER FIRING EXERCISES

The purpose of 10-meter firing is to develop skills in the delivery of initial bursts on target. When conducted properly, it will train gunners in the basic skills of zeroing, controlling the burst, traversing, and traversing and searching techniques. This paragraph discusses firing the 10-meter exercise on the multipurpose transition range; however, it is conducted the same on a basic 10-meter range except that the groups will be broken down to fit the firing lanes. The course is designed to fire the tripod-mounted M2. The basic MG target is used for all 10-meter firing and it allows four gunners to use it for practice or two gunners for practice and qualification. Those units wanting to fire qualification right after practice should use section A for practice and B for qualification for the first gunner, and sections C and D for the second gunner. Ten-meter firing will be conducted IAW Firing Table I (Figure C-3).

TASK	CONDITIONS TARGET/SITUATION	AMMO	STANDARD
1. Zero the M2 machine gun at 10 meters.	Instruct the gunner to engage scoring paster 1 in his assigned section with 6 single rounds in two 3-round shot groups and then paster 2 with the remaining rounds.	12 single rounds of 12.7-mm	Gunner must impact 4 of 6 rounds of the 3-round shot groups within paster 2 of his assigned section.
2. Engage a 10-meter target using controlled-burst techniques.	Instruct the gunner to engage paster 3 in his assigned section using controlled bursts, then engage paster 4 in the same manner. Gunner will use 5- to 7-round bursts for this engagement.	Two 7-round belts of 12.7-mm.	Gunner must impact one controlled burst on pasters 3 and 4 in his assigned section. (No score required.)
3. Engage scoring pasters 5 through 6 using the traverse and search technique of fire.	Instruct the gunner to engage pasters 5 through 6 using traverse and search technique of fire. Gunner will use 5- to 7-round bursts for this engagement.	35-round belt of 12.7-mm.	Gunner must impact one round on each scoring paster of 5 through 6 in his assigned section. (No score required.)
4. Engage scoring pasters 7 through 8 using the traverse and search technique of fire.	Instruct the gunner to engage pasters 7 through 8 using traverse and search technique of fire. Gunner will use 5- to 7-round bursts for this engagement.	56-round belt of 12.7-mm.	Gunner must impact one round on each scoring paster of 7 through 8 in his assigned section. (No score required.)

Figure C-3. Ten-meter Firing Table I.

TASK	CONDITIONS TARGET/SITUATION	AMMO	STANDARD
5. Engage target using controlled-burst fire.	Instruct the gunner to engage pasters 1 through 4 in his assigned section using controlled-burst fire. Gunner will use 5- to 7-round bursts for this engagement.	28-round belt of 12.7-mm.	Gunner must impact at least four rounds on each scoring paster 1 through 4 in his assigned section.
6. Engage scoring pasters 7 through 8 using the traverse and search technique of fire.	Instruct the gunner to engage pasters 7 through 8 using traverse and search technique of fire. Gunner will use 5- to 7-round bursts for this engagement.	56-round belt of 12.7-mm.	Gunner must impact at least four rounds on each scoring paster 5 through 6 in his assigned section.
7. Engage scoring pasters 5 through 6 using the traverse and search technique of fire.	Instruct the gunner to engage pasters 5 through 6 using traverse and search technique of fire. Gunner will use 5- to 7-round bursts for this engagement.	35-round belt of 12.7-mm.	Gunner must impact at least four rounds on each scoring paster 7 through 8 in his assigned section.

Figure C-3. Ten-meter Firing Table I, continued.

a. **Objective.** In order for the M2 gunner to become proficient with the machine gun, the following objectives must be considered.

- Obtain an accurate initial burst.
- Master the technique of controlled burst firing.
- Traverse and search the machine gun effectively.
- Observe and adjust fire.
- Operate with speed.

b. **Organization.** The unit is organized into groups of 10. Each group is assigned a firing order number. One order becomes gunners and the other assistant gunners. The gunners and assistant gunners are assigned lanes and required to setup their guns and perform pre-fire checks.

(1) *Ten-meter practice fire (Tasks 1 through 4).*

(a) The gunner is required to set his rear sight at 500 yards. On command, the first order zeros using scoring pasters 1 and 2 of their assigned section.

(b) At the completion of zeroing, the gunners are required to engage the next two aiming pasters (scoring pasters 3 and 4 of the same section), using controlled bursts, and then area targets 5 through 6 and 7 through 8, using traverse and search techniques. Time is allowed between bursts to permit gunners to observe and adjust their fire.

(c) After the first order has fired, the second order fires the course in the same manner using the next assigned section. After both orders have fired, the guns are cleared.

(2) *Ten-meter qualification (Tasks 5 through 7).*

(a) The gunner is then required to set his rear sight at 550 yards. On command, the first order fires at scoring pasters 1 through 4 of their assigned section.

(b) At the completion of their linear engagement, commands are given to require the gunners to engage area targets 5 through 6 and then 7 through 8, using traverse and search techniques. Time is allowed between bursts to permit gunners to observe and adjust their fire.

(c) After the first order has fired qualification, the second order fires the course in the same manner using the next assigned section. After both orders have fired, the guns are cleared.

c. **Target Analysis.** The exercises use the basic machine gun target (FSN 6920-078-5128) (Figure C-4). The following explanation of the target, including the size of the aiming pasters and scoring spaces, will aid in zeroing the M2 and will facilitate control during firing exercises.

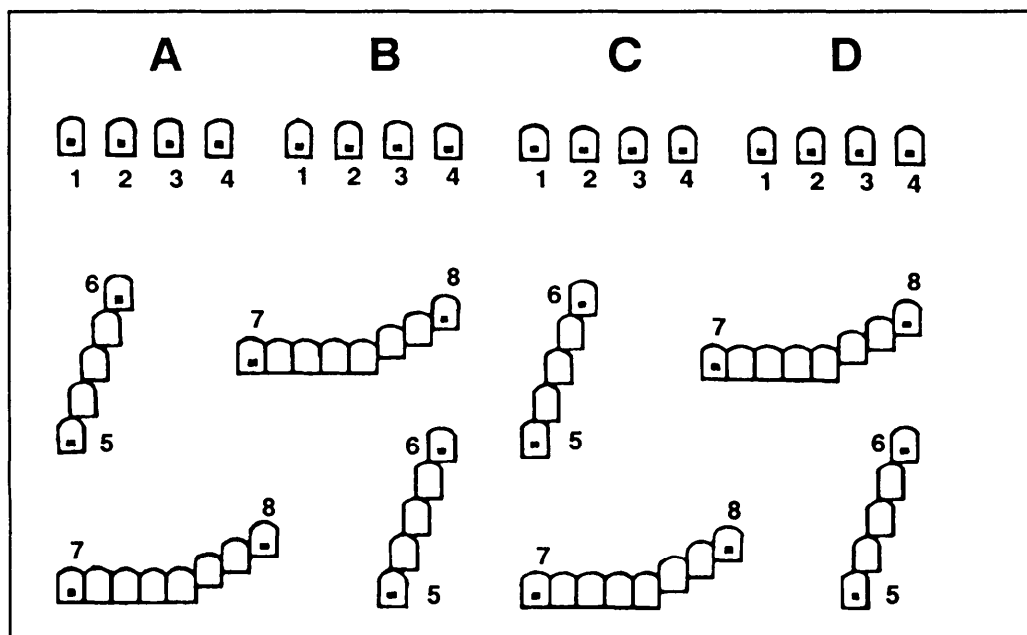

Figure C-4. Basic machine gun target.

(1) The target consists of four sections lettered A, B, C, and D. Each section has four point targets numbered 1, 2, 3, and 4; and two sets of area targets numbered 5 through 6 and 7 through 8. Each space is 4 centimeters wide and 5 centimeters high. The black aiming pasters within some numbered scoring spaces are 1-centimeter squares. Firing at targets 1 through 4 allows the gunner to use the traverse-fire technique

targets 5 through 6 and 7 through 8 give them practice in traverse and search techniques.

(a) Point targets. Point targets on the basic machine gun target are considered to be pasters 1 through 4 of section A, B, C, and D. Firing at point targets exposes the gunner to zeroing techniques and controlled-burst fire techniques. Targets 1 through 4 will also be used as a linear target for qualification.

(b) Area targets. Area targets on the basic machine gun target are considered to be pasters 5 through 6 and 7 through 8 of section A, B, C, and D. Target group 5 through 6 exposes the gunner to T&E manipulation when using the tripod mount and body position changes to engage targets in depth (elbow position changes). This causes him to use a series of aiming points to disburse fire across the target when using the tripod. Target group 7 through 8 exposes the gunner to position changes to engage linear targets with depth. It causes him to control the burst length from the weapon, use a series of aiming points, and disburse fire across the target.

(2) Targets are analyzed and scored to determine the gunner's proficiency and to see if more training is needed in any of the fundamentals of M2 gunnery. During firing with a properly zeroed weapon, a target is best analyzed by considering the common errors of M2 gunnery (Figure C-5).

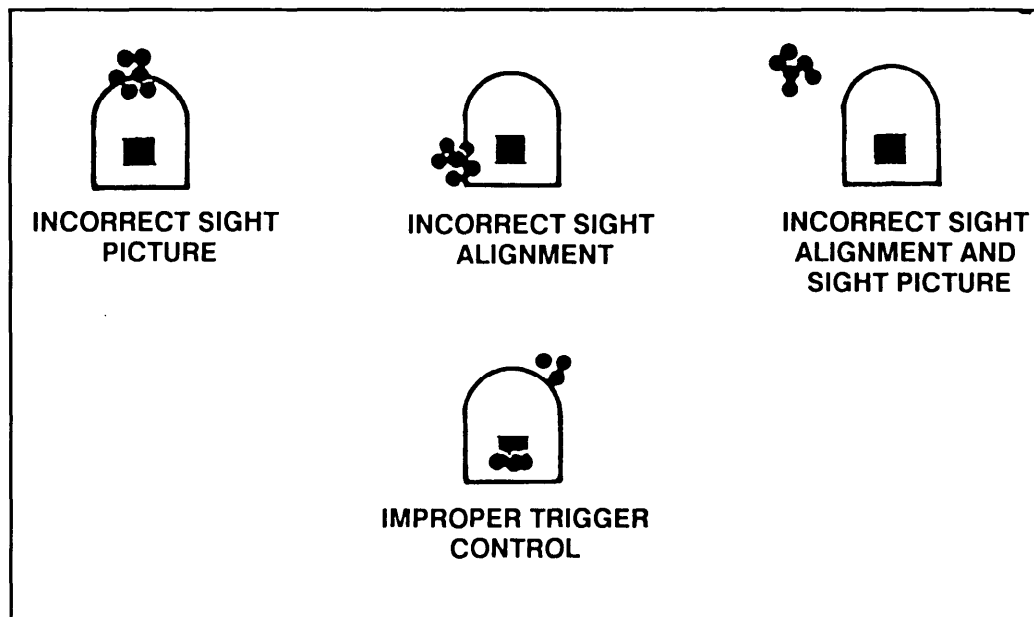

Figure C-5. Common errors found on the basic MG target.

NOTE: Large shot groups are usually caused by incorrect position and grip; small shot groups outside of the scoring space are usually caused by incorrect sight alignment, sight picture, or zero.

d. **The 10-Meter Zero.** Ten-meter zeroing is accomplished by adjusting the rear sight until the strike of the projectile coincides with the point of aim at a given range. On the 10-meter range, the elevation scale must be set at 500 yards so that it can impact on the desired aiming point. Before zeroing the weapon, the gunner must first center the rear sight for windage by aligning the index with the center of the windage scale.

e. **Controlled Burst Firing.** This firing exercise reinforces the dry-fire experience and allows the gunner practice in firing of controlled bursts and in providing the most accurate and tightest shot groups obtainable with the M2.

f. **Ammunition Issue.** The ammunition for the firing of this exercise will be broken down at the ammunition point and issued to each assistant gunner as he is assigned a firing point. The total ammunition for this exercise is 236 rounds (117 for practice and 119 for qualification). Issue will consist of the following rounds or belts:

- Task 1, 12 single rounds
- Task 2, two 7-round belts.
- Task 3, one 35-round belt.
- Task 4, one 56-round belt.
- Task 5, one 28-round belt.
- Task 6, one 56-round belt.
- Task 7, one 35-round belt.

g. **Firing Sequence.** Firing of Table I will be conducted in the following manner. These procedures pertain to firing with a single gunner using sections A and B; if there is a second gunner, he will use C and D.

(1) *Task 1, Zero.*

(a) The gunner will fire 3 rounds, single shot, at paster A1.

(b) The gunner will then move down range to observe the shot group and triangulate it. No adjustments to the weapon will be made at this time.

(c) The gunner will then fire another 3 single rounds at A1.

(d) The gunner then goes down range to observe the shot group, triangulate it, and make necessary adjustments to his weapon.

(e) The gunner repeats steps (c) and (d), but shoots at paster A2.

NOTE: If the gunner is able to zero his weapon using 9 rounds, have him use the remaining 3 to confirm his zero. If the gunner is unable to zero within 12 rounds, remove him from the firing line and give him remedial training.

(2) *Task 2, Controlled Burst Firing.*

- (a) The gunner will fire the first burst of 5 to 7 rounds at paster 3.
- (b) The gunner then goes down range to observe, marks the projectile holes, and analyzes his burst.
- (c) The gunner repeats steps (a) and (b), but fires at paster 4 of same section.

NOTE: The primary purpose of this task is to get the gunner to fire 5- to 7-round bursts. Impact on the target is desired, but not necessary to complete this task. The gunner will fire a 5- to 7-round burst at each paster.

(3) *Task 3, Traverse and Search Fire.*

- (a) The gunner will engage pasters 5 through 6, section A, firing a 5- to 7-round burst for each paster, using the traverse and search technique.
- (b) The gunner will then move down range to observe and analyze his targets.

NOTE: These tasks are fired from the tripod firing position. If the gunner shows difficulty in manipulating the weapon, remove him from the firing line and give him remedial training.

(4) *Task 4, Traverse and Search Fire.*

- (a) The gunner will engage pasters 7 through 8, section A, firing a 5- to 7-round burst at each paster, using the traverse and search technique.
- (b) The gunner will then move down range to observe and analyze his targets.

(5) *Task 5, Traverse Fire.*

- (a) The gunner will engage pasters 1 through 4, section B, firing a 5- to 7-round burst at each paster, using the traverse technique.
- (b) The gunner will then move down range to observe and analyze his targets.

(6) *Task 6, Traverse and Search Fire.*

- (a) The gunner will engage pasters 7 through 8, section B, firing a 5- to 7-round burst at each paster, using the traverse and search technique.
- (b) The gunner will then move down range to observe and analyze his targets.

(7) *Task 7, Traverse and Search Fire.*

(a) The gunner will engage pasters 5 through 6, section B, firing a 5- to 7-round burst at each paster, using the traverse and search technique.

(b) The gunner will then move down range to observe and analyze his targets.

DANGER

Before any gunner goes down range, the lane NCO must ensure that the weapon has been properly cleared. Anyone observing any unsafe acts should immediately call a cease fire and notify range personnel.

h. Scoring Procedures. When scoring the 10-meter target, all scoring spaces are scored (1 through 4, 5 through 6, and 7 through 8). One point is given for each round impacting within each space. Rounds touching the boundary of a scoring space are considered hits, but they can be counted in only one scoring space. When firing at 1 through 4 with 28 rounds, the maximum score is 28 points. In group 5 through 6, five scoring spaces are engaged with 35 rounds with a possible score of 35 points. When firing groups 7 through 8, eight scoring spaces are engaged with 56 rounds with a possible score of 56 points.

(1) The total possible score of both groups is 119 points. A minimum of 84 points is required to pass the 10-meter course of fire.

(2) Soldiers failing to achieve minimum standards must be retrained and retested in a dry-fire mode until proficiency is demonstrated. They may not move on to transition firing. Soldiers should then re-fire the 10-meter portion with close supervision and coaching to ensure that the fundamentals are applied properly during live fire.

C-3. TRANSITION FIRING EXERCISES

Transition firing of the M2 machine gun will teach the gunner some techniques of fire that he may encounter in combat situations. The gunner will field zero his weapon and also incorporate the techniques of fire during limited visibility and NBC environments. The gunner needs to be aware that during certain situations his capabilities will be degraded. He is expected to compensate for these situations by applying all available techniques. Within this training, the gunner will be required to apply all the fundamentals of gunnery learned in preparatory gunnery training and 10-meter firing. Instructors should encourage gunners to perform immediate action if a stoppage occurs during fire. This procedure may be modified if local policies require the gunners to notify the range personnel first.

- a. **Objectives.** The objectives of transition fire are —
- To engage targets at long ranges with the tripod-mounted machine gun.
 - To understand the characteristics of fire.
 - Ž To field zero the M2 machine gun.
 - Ž To use range estimation to determine the distance to targets.
 - Ž To apply the method of adjusted point of aim.

b. **Organization.** Organization of a unit for transition firing is conducted the same as for 10-meter firing. Field zeroing is the first firing task of transition day-fire phase. The transition day-fire portion of the course must be fired to become a qualified M2 gunner.

c. **Ammunition Issue.** The ammunition for the firing of this exercise will be broken down at the ammunition point and issued to each assistant gunner as he is assigned a firing point. The total ammunition for this exercise is 182 rounds, and issue will consist of two belts; one 28-round belt and one 154-round belt.

d. **Firing Sequence.** Firing of Table II (Figure C-6) will be conducted in the following manner. These procedures pertain to firing with a single gunner using a tripod-mounted M2. If there is a second gunner, he will use the same procedures.

(1) *Task 1, Field Zero.*

(a) The gunner must first center the rear sight in the same manner as sight setting for 10-meter firing. He selects the appropriate range mark with his elevation knob.

(b) The gunner will load one 28-round belt of ammunition and fire a burst of 5 to 7 rounds at the 550-meter, double E-type silhouette.

(c) If the impact of the rounds (beaten zone) is over the target, the gunner has probably fired with an incorrect sight picture (too high on the target). He needs to relay the gun on the original point of aim and then he relays back on the target and fires again. If the gunner again fails to zero with a proper sight picture, he should have the unit armorer inspect the weapon before continuing the zeroing procedure.

(d) The gunner will observe the beaten zone and make adjustments to the sights so the round will impact on the target.

(e) After adjustments are made, the gunner will then relay on the center base of the target and fire another 5- to 7-round burst.

(f) The gunner will repeat steps c, d, and e with the remaining rounds.

NOTE: If the gunner is unable to zero within 28 rounds, he is removed from the firing line and given remedial training.

(2) *Task 2 through Task 8, Single and Multiple Engagements.*

(a) The gunner will load one 154-round belt of ammunition and fire bursts of 5 to 7 rounds at double E-type silhouettes at ranges of 800, 400, 700, and 1,000 meters at vehicular targets. He will also engage multiple double E-type silhouettes targets at 400 to 700; 550 and 800; and 400, 550, and 1,000 meters respectively.

(b) The gunner will observe the beaten zone and make adjustments as necessary to hit the targets.

(c) After firing is completed, weapons will be cleared and the gunner critiqued. If there is a second gunner to fire, the entire procedure will be repeated.

NOTE: After both gunners have fired for practice, they will then be assigned new lanes and issued more ammunition for record firing. If possible, the gunner should keep the same weapon he used for practice fire. The only change in the above procedures will be in step (c); here, the gunner will be scored along with the critique. If the gunner is unable to meet standard, he is removed from the firing line, given remedial training, and re-fired.

DANGER

Before any gunner changes lanes, the lane NCO must ensure that the weapon has been properly cleared. Anyone observing any unsafe acts should immediately call a cease fire and notify range personnel.

TASK	CONDITIONS TARGET/SITUATION	AMMO	STANDARD
1. Zero the M2 machine gun.	Gunner is in stationary tripod firing position and engages a 550-meter, double E-type silhouette. Gunner will use 5-to 7-round bursts for this engagement.	28-round belt of 12.7-mm.	Gunner must impact one burst on the 550-meter target.
2. Engage a single, double E-type silhouette.	Gunner is in stationary tripod firing position and engages an 800-meter, double E-type silhouette. Gunner will use 5-to 7-round bursts for this engagement.	14 rounds of 12.7-mm.	Gunner must impact one burst on the 800-meter target within 20 seconds.

Figure C-6. Practice/Qualification Table II.

TASK	CONDITIONS TARGET/SITUATION	AMMO	STANDARD
3. Engage a single. double E-type silhouette.	Gunner is in stationary tripod firing position and engages a 400-meter, double E-type silhouette. Gunner will use 5-to 7-round bursts for this engagement.	14 rounds of 12.7-mm	Gunner must impact one burst on the 400-meter target within 20 seconds.
4. Engage a single. double E-type silhouette.	Gunner is in stationary tripod firing position and engages a 700-meter, double E-type silhouette. Gunner will use 5-to 7-round bursts for this engagement.	14 rounds of 12.7-mm	Gunner must impact one burst on the 700-meter target within 25 seconds.
5. Engage a single. double E-type silhouette.	Gunner is in stationary tripod firing position and engages a 1,000-meter, vehicle type silhouette. Gunner will use 5-to 7-round bursts for this engagement.	14 rounds of 12.7-mm	Gunner must impact one burst on the 1,000-meter target within 25 seconds.
6. Engage multiple double E-type silhouettes.	Gunner is in stationary tripod firing position and engages 400-and 700-meter, double E-type silhouettes. Gunner will use 5-to 7-round bursts for this engagement.	28 rounds of 12.7-mm.	Gunner must impact one burst on each target within 35 seconds.
7. Engage multiple double E-type silhouettes.	Gunner is in stationary tripod firing position and engages 550-and 800-meter, double E-type silhouettes. Gunner will use 5-to 7-round bursts for this engagement.	28 rounds of 12.7-mm.	Gunner must impact one burst on each target within 35 seconds.
8. Engage multiple double E-type silhouettes.	Gunner is in stationary tripod firing position and engages 400-, 550-and 1,000 meter, double E-type and vehicle silhouettes. Gunner will use 5-to 7-round bursts for this engagement.	42 rounds of 12.7-mm.	Gunner must impact one burst on each target within 45 seconds.

Figure C-6. Practice/Qualification Table II, continued.

e. **Scoring Procedures.** One point is given for each target hit with an additional 2-point bonus if the target is hit on the first burst. The total possible points for day fire is 33. A minimum 7 points (7 out of 11 exposures) is required to meet standard on the day-fire course.

C-4. NBC FIRING

Since NBC plays an important part in our preparation for war on the modern battlefield, it is important that each soldier is prepared to accomplish the mission even if the area is contaminated and he must wear protective gear.

a. **Objectives.** The objectives of this training are:

- To teach the gunners to take appropriate action when notified of a contaminated area.
- Ž To identify targets while in a contaminated area.
- Ž To engage targets while in appropriate NBC gear.

b. **Organization.** The unit is organized the same as in paragraph C-2b, except both the gunner and assistant gunner must wear protective masks. Protective clothing is optional.

c. **Ammunition Issue.** The ammunition for the firing of this exercise will be broken down at the ammunition point and issued to each assistant gunner as he is assigned a firing point. The total ammunition for this exercise is 182 rounds, and issue will consist of two belts; one 28-round belt and one 154-round belt.

d. **Firing Sequence.** Firing of Table III (Figure C-7, pages C-16 and C-17) will be conducted in the following manner. These procedures pertain to firing with a single gunner using a tripod-mounted M2. If there is a second gunner, he will use the same procedures.

(1) *Task 1, Field Zero.*

(a) The gunner must first center the rear sight in the same manner as setting the sights for 10-meter firing. He selects the appropriate range mark with his elevation knob.

(b) The gunner will load one 28-round belt of ammunition and fire a burst of 5 to 7 rounds at the 550-meter, double E-type silhouette.

(c) If the impact of the rounds (beaten zone) is over the target, the gunner has probably fired with an incorrect sight picture (too high on the target). He should re-fire concentrating on the proper point of aim and sight picture. If the impact is still off, have the unit armorer correct the calibration and the gunner repeat the zeroing procedure.

(d) The gunner will observe the beaten zone and make adjustments to the sights so the round will impact on the target.

(e) After adjustments are made, the gunner will then relay on the center base of the target and fire another 5- to 7-round burst at the same target.

(f) The gunner will repeat steps c, d, and e with the remaining rounds.

NOTE: If the gunner is unable to zero within 28 rounds, he is removed from the firing line and given remedial training.

(2) *Task 2 through Task 8, Single and Multiple Engagements.*

(a) The gunner will load one 154-round belt of ammunition and fire bursts of 5 to 7 rounds at double E-type silhouettes at ranges of 800,400,

700, and a 1,000-meter vehicular target. He will also engage multiple, double E-type silhouettes targets at 400 and 700; 550 and 800; and 400, 500, and 1,000 meters, respectively.

(b) The gunner will observe the beaten zone and make adjustments as necessary to hit the targets.

(c) After firing is completed, weapons will be cleared and the gunner critiqued. If there is a second gunner to fire, the entire procedure will be repeated.

NOTE: After both gunners have fired for practice, they will then be assigned new lanes and issued more ammunition for record firing. If possible, the gunner should keep the same weapon he used for practice fire. The only change in the above procedures will be in the last step; here, the gunner will be scored along with the critique. If the gunner is unable to meet standard, he is removed from the firing line, given remedial training, and re-fired.

DANGER
 Before any gunner changes lanes, the lane NCO must ensure that the weapon has been properly cleared. Anyone observing any unsafe acts should immediately call a cease fire and notify range personnel.

e. **Scoring Procedures.** One point is given for each target hit with an additional 2-point bonus if the target is hit on the first burst. The total possible points for day fire is 33. A minimum of 7 points (7 out of 11 exposures) is required to meet standard on the NBC fire course.

TASK	CONDITIONS TARGET/SITUATION	AMMO	STANDARD
1. Zero the M2 machine gun.	Gunner is in stationary tripod firing position and engages a 550-meter, double E-type silhouette. Gunner will use 5-to 7-round bursts for this engagement.	28-round belt of 12.7-mm.	Gunner must impact one burst on the scaled, 550-meter target.
2. Engage a single, double E-type silhouette at 800 meters while wearing a protective mask.	Gunner is in stationary tripod firing position and engages a 800-meter, double E-type silhouette. Gunner will use 5-to 7-round bursts for this engagement.	14 rounds of 12.7-mm.	Gunner must impact one burst on the 800-meter target within 20 seconds.

Figure C-7. NBC Qualification Table III.

TASK	CONDITIONS TARGET/SITUATION	AMMO	STANDARD
3. Engage a single, double E-type silhouette at 400 meters while wearing a protective mask.	Gunner is in stationary tripod firing position and engages a 400-meter, double E-type silhouette. Gunner will use 5-to 7-round bursts for this engagement.	14 rounds of 12.7-mm.	Gunner must impact one burst on the 400-meter target within 20 seconds.
4. Engage a single, double E-type silhouette at 700 meters while wearing a protective mask.	Gunner is in stationary tripod firing position and engages a 700-meter, double E-type silhouette. Gunner will use 5-to 7-round bursts for this engagement.	14 rounds of 12.7-mm.	Gunner must impact one burst on the 700-meter target within 20 seconds.
5. Engage a single, double E-type silhouette at 1,000 meters while wearing a protective mask.	Gunner is in stationary tripod firing position and engages a 1,000-meter, vehicle type silhouette. Gunner will use 5-to 7-round bursts for this engagement.	14 rounds of 12.7-mm.	Gunner must impact one burst on the 1,000 meter target within 25 seconds.
6. Engage multiple, double E-type silhouettes at 400 and 700 meters while wearing a protective mask.	Gunner is in stationary tripod firing position and engages 400-and 700-meter, double E-type silhouettes. Gunner will use 5-to 7-round bursts for this engagement.	28 rounds of 12.7-mm.	Gunner must impact one burst on each target within 35 seconds.
7. Engage multiple, double E-type silhouettes at 550 and 800 meters while wearing the protective mask.	Gunner is in stationary tripod firing position and engages 550-and 800-meter, double E-type silhouettes. Gunner will use 5- to 7-round bursts for this engagement.	28 rounds of 12.7-mm.	Gunner must impact one burst on each target within 35 seconds.
8. Engage multiple, double E-type silhouettes at 400, 500, and 1,000 meters while wearing the protective mask.	Gunner is in stationary tripod firing position and engages scaled 400-,500-, and 1,000-meter, double E-type and vehicle type silhouettes. Gunner will use 5-to 7-round bursts for this engagement.	42 rounds of 12.7-mm.	Gunner must impact one burst on each target within 45 seconds.

Figure C-7. NBC Qualification Table III, continued.

C-5. NIGHT-FIRE EXERCISE

The night-fire exercise gives the soldiers the practical application of engaging targets using the AN/TVS-5 at night or during limited visibility.

a. **Objectives.** The objectives of this training are:

- To teach the gunners to zero the AN/TVS-5 to the M2.
- To engage targets at different ranges using the AN/TVS-5.
- To detect targets using the AN/TVS-5.

b. **Organization.** Organization of a unit for night firing is conducted the same as day fire. AN/TVS-5 zeroing is the first firing task of the night-fire phase. The night-fire portion of the course is also a requirement to become a qualified M2 gunner.

c. **Ammunition Issue.** The ammunition for the firing of this exercise will be broken down at the ammunition point and issued to each assistant gunner as he is assigned a firing point. The total ammunition for this exercise is 180 rounds, and issue will consist of the following rounds or belts:

- Task 1, 12 single rounds and two 7-round belts
- Ž Task 2 through Task 8, one 154-round belt.

d. **Firing Sequence.** Firing of Table IV (Figure C-8) will be conducted in the following manner; these procedures pertain to a single gunner using a tripod-mounted M2 with an AN/TVS-5. If there is a second gunner, he will use the same procedures.

(1) *Task 1, Zero the AN/TVS-5.*

(a) The gunner must first mount the AN/TVS-5 to the weapon and place it into operation. Once the device is mounted, the gunner will fire a 7-round burst to seat the device, then fire another 7-round burst and tighten the device to make sure it is settled.

(b) The gunner must then center the reticle pattern in the field of view of the device. He then places the reticle aiming point on the 50-meter zero target aim point and fires three single rounds.

NOTE: Each click of the azimuth or elevation adjustment actuator moves the strike of the round 1/2 inch at 50 meters. One click of adjustment moves the reticle one square of the target at 50 meters.

(c) If the impact of the round (beaten zone) is over the target, the gunner has probably fired with an incorrect sight picture (too high on the target). He should re-fire concentrating on the proper point of aim and AN/TVS-5 sight picture. If the gunner again fails to zero with a proper device sight picture, he should inspect the sight calibration of the device.

(d) The gunner will observe the beaten zone and make adjustments to the sights so the strike of the round impacts on the target.

(e) After adjustments are made, the gunner will then fire another round at the same target until zero is obtained.

NOTE: If the gunner is able to zero his weapon using 12 rounds, he is then ready to continue the course. If not, he is removed from the firing line and given remedial training.

(2) *Task 2 through Task 8, Single and Multiple Engagements.*

(a) The gunner will load one 154-round belt of ammunition and fire bursts of 5 to 7 rounds at double E-type silhouettes at ranges of 800, 400, 700, and a 1,000-meter vehicular target. He will also engage multiple, double E-type silhouettes targets at 400 to 700; 550 and 800; and 400, 500, and 1,000 meters, respectively.

(b) The gunner will observe the beaten zone and make adjustments as necessary to hit the targets.

(c) After firing is completed, weapons will be cleared and the gunner critiqued. If there is a second gunner to fire, the entire procedure will be repeated.

NOTE: After both gunners have fired for practice, they will then be assigned new lanes and issued more ammunition for record firing. If possible, the gunner should keep the same weapon he used for practice fire. The only change in the above procedures will be in the last step; here, the gunner will be scored along with the critique. If the gunner is unable to meet standard, he is removed from the firing line, given remedial training, and re-fired at the commander's discretion.

DANGER

Before any gunner changes lanes, the lane NCO must ensure that the weapon has been properly cleared. Anyone observing any unsafe acts should immediately call a cease fire and notify range personnel.

e. **Scoring Procedures.** One point is given for each target hit with an additional 2-point bonus if the target is hit on the first burst. The total possible points for night fire is 33. A minimum 7 points (7 out of 11 exposures) is required to meet standard on the night-fire course.

NOTE: Firing Table IV is set up for gunners to engage targets out to 1,000 meters under moonlight. However, if visibility is limited by other conditions, then the commander may use his discretion to alter the ranges for better visibility.

TASK	CONDITIONS TARGET/SITUATION	AMMO	STANDARD
1. Zero the AN/TVS-5 to the M2 machine gun.	Gunner is in stationary tripod firing position at 50 meters and engages an M16A1/A2 zero target. Gunner will use single shots for this engagement. Two bursts will be used to spot the device.	12 single 12.7-mm rounds and two 7-round belts.	Gunner must impact 4 of 6 rounds of two 3-round shot groups within a 4-cm circle IAW FM 23-26.
2. Engage a single, double E-type silhouette at 800 meters while using the AN/TVS-5.	Gunner is in stationary tripod firing position and engages an 800-meter, double E-type silhouette. Gunner will use 5-to 7-round bursts for this engagement.	14 rounds of 12.7-mm.	Gunner must impact one burst on the 800-meter target within 20 seconds.
3. Engage a single, double E-type silhouette at 400 meters while using the AN/TVS-5.	Gunner is in stationary tripod firing position and engages a 400-meter, double E-type silhouette. Gunner will use 5-to 7-round bursts for this engagement.	14 rounds of 12.7-mm.	Gunner must impact one burst on the 400-meter target within 20 seconds.
4. Engage a single, double E-type silhouette at 700 meters while using the AN/TVS-5.	Gunner is in stationary tripod firing position and engages a 700-meter, double E-type silhouette. Gunner will use 5-to 7-round bursts for this engagement.	14 rounds of 12.7-mm.	Gunner must impact one burst on the 700-meter target within 25 seconds.
5. Engage a single, double E-type silhouette at 1,000 meters while using the AN/TVS-5.	Gunner is in stationary tripod firing position and engages a 1,000-meter, double E-type silhouette. Gunner will use 5- to 7-round bursts for this engagement.	14 rounds of 12.7-mm.	Gunner must impact one burst on the 1,000-meter target within 25 seconds.
6. Engage multiple, double E-type silhouettes at 400 and 700 meters while using the AN/TVS-5.	Gunner is in stationary tripod firing position and engages 400- and 700-meter, double E-type silhouettes. Gunner will use 5- to 7-round bursts for this engagement.	28 rounds of 12.7-mm.	Gunner must impact one burst on each target within 35 seconds.
7. Engage multiple, double E-type silhouettes at 550 and 800 meters while using the AN/TVS-5.	Gunner is in stationary tripod firing position and engages 550- and 800-meter, double E-type silhouettes. Gunner will use 5- to 7-round bursts for this engagement.	28 rounds of 12.7-mm.	Gunner must impact one burst on each target within 35 seconds.
8. Engage multiple, double E-type silhouettes at 400, 550, and 1,000 meters while using the AN/TVS-5.	Gunner is in stationary tripod firing position and engages 400-, 550-, and 1,000-meter, double E-type silhouettes. Gunner will use 5- to 7-round bursts for this engagement.	42 rounds of 12.7-mm.	Gunner must impact one burst on each target within 45 seconds.

Figure C-8. Night Fire Qualification Table IV.

C-6. QUALIFICATION STANDARDS

Qualification of the M2 consists of achieving the minimum standards for 10-meter, day, night, and NBC firing tables. One point is given for each round impacting in each space for Table I. For Tables II, III, and IV, one point is allowed for each target hit with an additional 2-point bonus when the target is hit with the first burst. The maximum possible for Table I is 119 points. A minimum of 12 points (12 out of 17 pasters) is required. The maximum score for Tables II, III, or IV is 33 points each. The minimum score of 23 must be obtained on Table II, III, and IV, which meets the standard for qualification.

a. **Ratings.** The overall ratings are scored as follows:

MAXIMUM	218
EXPERT	196 to 218
FIRST CLASS	174 to 195
SECOND CLASS	153 to 173
UNQUALIFIED	152 and below

b. **Scorecard.** An example of the scorecard (DA Form 7007-R, Machine Gun Scorecard for M2) (Figure C-9, page C-22), which will be reproduced locally, is used for recording the gunner's performance on the M2 machine gun qualification range. The instructions for filling out this scorecard are on the back of the form (Figure C-10, page C-23).

MACHINE GUN SCORECARD FOR M2												See back of this form for instructions.						
For use of this form, see FM 23-65; the proponent agency is TRADOC.																		
NAME: SFC BILLY GREENE		SSAN: 123-45-6789				UNIT: C 2/34 INF				DATE: 6 NOV 90		LANE: 3						
TABLE I			TABLE II				TABLE III				TABLE IV							
TSK	Range (Meters)	HIT	PTS	RANGE (Meters)	TIME	HIT	PTS	BON	RANGE (Meters)	TIME	HIT	PTS	BON	RANGE (Meters)	TIME	HIT	PTS	BON
1	10	No Score		550	None	NA	NA	NA	550	None	NA	NA	NA	50	None	NA	NA	NA
2	10	No Score		800	20 Sec	X	1	2	800	20 Sec	X	1	2	800	20 Sec	X	1	2
3	10	No Score		400	20 Sec	X	1	2	400	20 Sec	X	1	2	400	20 Sec	X	1	2
4	10	No Score		700	25 Sec	X	1	2	700	25 Sec	X	1	2	700	25 Sec	X	1	2
5	10	X	20	1,000	25 Sec	X	1	2	1,000	25 Sec	X	1	2	1,000	25 Sec	X	1	2
6	10	X	30	400	35 Sec	X	1	2	400	35 Sec	X	1	2	400	35 Sec	X	1	2
		X	45	550	35 Sec	X	1	2	550	35 Sec	X	1	2	550	35 Sec	X	1	2
7	10	X		800	35 Sec	X	1	0	800	35 Sec	X	1	0	800	35 Sec	X	1	0
8				400	45 Sec	X	1	0	400	45 Sec	X	1	0	400	45 Sec	X	1	0
				550		X	1	2	550		X	1	2	550		X	1	2
				1,000		X	1	2	1,000		X	1	2	1,000		X	1	2
TOTAL					95				29				31					
TABLES		I	II	III	IV	TOTAL SCORE												
		95	29	29	31	184												
OIC Signature: CPT Melton A. Young												Grader: SFC Gary Rumba		Rating: GUNNER FIRST CLASS				
<small>AUTHORITY: 10USC30129(g) Executive Order 9397, PRINCIPAL PURPOSE(S): Records individual's performance on record fire range. ROUTINE USE(S): Evaluation of individual's proficiency and basis for determination of award of proficiency badge. SSN is used for positive identification purposes only. MANDATORY OR VOLUNTARY DISCLOSURE AND EFFECT ON INDIVIDUAL: NOT PROVIDING INFORMATION. Voluntary, individuals not providing information cannot be rated/scored on a mass basis.</small>																		
DA Form 7007-R, Jun 91 Replaces DA Form 3867-R, Jun 72, which is obsolete.																		

Figure C-9. Example DA Form 7007-R, front.

- The following procedure will be used to fill out the scorecard.
1. **NAME:** Enter last name , first name, and middle initial.
 2. **SSN:** Enter gunner's social security number.
 3. **UNIT:** Enter unit designation.
 4. **DATE:** Enter date of firing.
 5. **LANE:** Enter the lane number for the firing point of your gunner.
 6. **HIT:** When firing Table I, enter the number of rounds impacting within the scoring space in task numbers 5, 6, and 7. For Tables II, III, and IV, enter an X when target is hit.
 7. **POINTS:** Enter 1 point for each round impacting within the scoring space in task numbers 5, 6, and 7 in Table I. Gunners will receive 1 point for each target hit in Tables II, III, and IV.
 8. **BONUS:** Entry is used only for Tables II, III, and IV. Two bonus points are awarded when gunner hits the target on initial burst of each target exposure.
 9. **TOTAL SCORE:** Enter the total of combined hits, points, and bonus scores.
- NOTE:** It is possible that a gunner may score the required points outlined for qualification. However the gunner must also score 70 percent on each firing table before he is considered a qualified gunner.

MAXIMUM	218
EXPERT	196-218
GUNNER FIRST CLASS	174-195
GUNNER SECOND CLASS	153-173
UNQUALIFIED	152 and below

Back, DA Form 7007-R, Jun 91

Figure C-10. Example DA Form 7007-R, back.

Section II. MULTIPURPOSE RANGE COMPLEX

The multipurpose range complex is designed to conduct armor and mobilized machine gun firing. Detailed setup and target configuration is described in FM 25-7; its layout is shown in Figure C-11. This section also discusses the mounted firing exercise, requirements for crews, rating procedures, and standards.

C-7. DESIGN SPECIFICS

The tower and administrative facilities must be positioned so they do not impede tactical maneuver onto or off of the range.

a. Hardened emplacements are for aerial gunnery exercises in addition to tank and BFV gunnery.

b. System calibration targets must be provided at ranges of 950, 1,200, and 1,500 meters, as shown in Figure C-11.

c. Gunnery tasks that require the use of dud-producing ammunition cannot be fired on the range proper. Provisions for these tasks must be made in impact areas adjacent to the range.

d. Double target mechanisms are recommended for use in the first six target groupings for BFV training, or for positioning throughout the range as needed to support local training requirements.

e. The administrative area is not shown in exact location or scale.

f. Additional defilade positions maybe required for BFV gunnery.

g. The addition of battle positions and positioning of personnel targets closer to the baseline may be necessary to permit BFV dismounted infantry training.

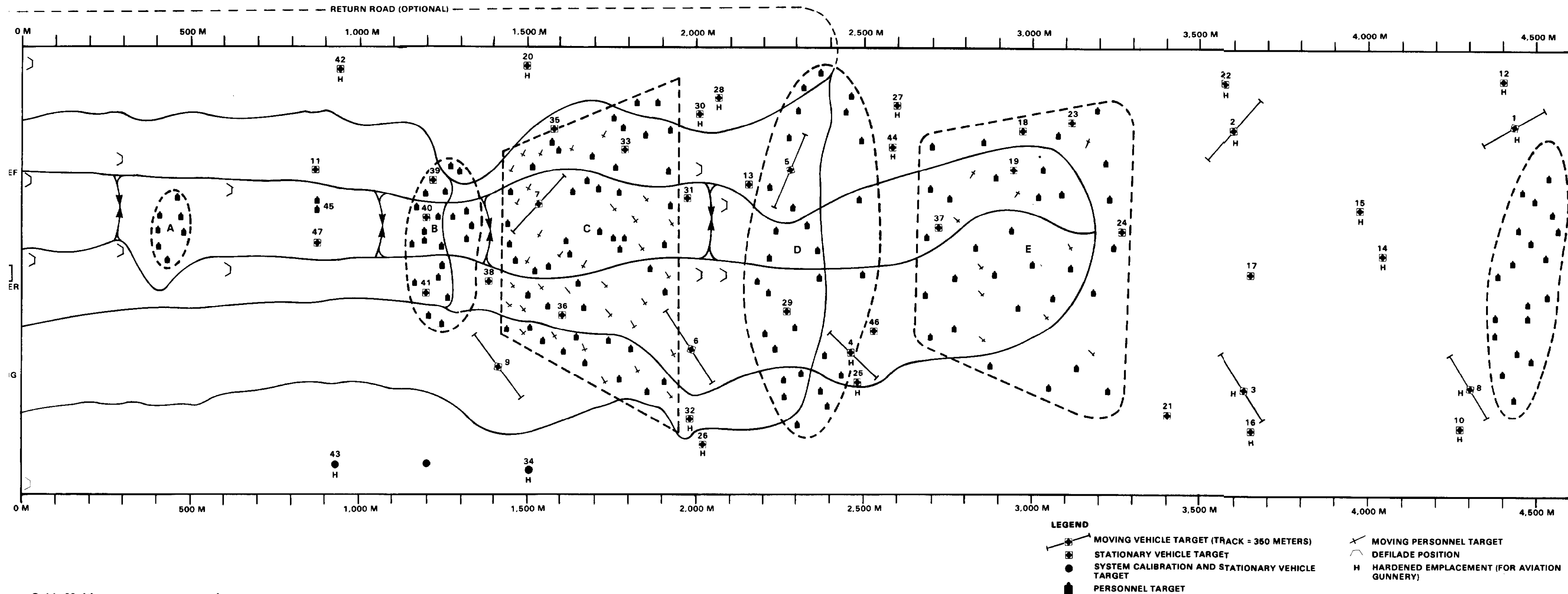

Figure C-11. Multipurpose range complex.

Carrier 2 will upload and wait at the ammunition point. When the course is clear, carrier 2 will move to the initial fire point followed by carrier 4 and proceed as stated. Carrier 3 should now be at the ammunition point for uploading.

(1) *Task 1, Conduct Prefire Inspection.*

(a) The crew will move forward to the initial firing position. Once the carrier is in position, the crew will perform a prefire inspection by setting the headspace and timing, and load a 7-round belt of ammunition.

(b) The gunner will then fire the 7-round belt at a 450-meter target to ensure the machine gun is operational.

NOTE: If the machine gun fails to fire or fires sluggishly, recheck the headspace and timing and attempt to fire again. If the situation continues, clear the weapon and have the carrier move off the firing course and report to the armorer to have the problem corrected.

(c) Upon completion of Task 1, the gunner will clear the weapon and await further instructions.

NOTE: To accomplish Task 2 and Task 3, the gunner will load one 28-round belt of ammunition.

(2) *Task 2, Engage Stationary Target From a Mounted Stationary Firing Position.*

(a) The gunner will engage a 450-meter stationary personnel target from the initial firing location.

(b) The gunner will use a 5- to 7-round burst for this engagement.

(c) The gunner will observe the beaten zone and make adjustments as necessary to hit the target.

(d) Upon completion of Task 2, the gunner will await further instructions.

(3) *Task 3, Engage Stationary Target From a Stationary Firing Position.*

(a) From the initial firing location, the gunner will engage an 850-meter stationary vehicle target.

(b) The gunner will use a 5- to 7-round burst for this engagement.

(c) The gunner will observe the beaten zone and make adjustments as necessary to hit the target.

(d) Upon completion of Task 3, the gunner will await further instructions.

NOTE: On command from the grader, the crew will move the carrier to the next predetermined firing location, load one 28-round belt, and conduct Task 4.

(4) *Task 4, Engage Moving and Stationary Targets From a Mounted Stationary Firing Position.*

(a) From the second predetermined firing location, the gunner will engage one moving vehicle target at a range of 800 meters and one stationary vehicle target at a range of 1,000 meters.

(b) The gunner will use a 5-to 7-round burst for this engagement.

(c) The gunner will observe the beaten zone and make adjustments as necessary to hit the targets.

(d) Upon completion of firing Task 4, the gunner will await further instructions.

NOTE: When conducting Task 5, the gunner will load one 28-round belt and engage targets from a moving carrier along a predetermined route.

(5) *Task 5, Engage Stationary Targets While Firing From a Moving Carrier.*

(a) The carrier will be moving along the predetermined firing route, at which time the gunner will engage stationary vehicle targets at ranges of 300 and 500 meters.

(b) The gunner will use a 5- to 7-round burst for this engagement.

(c) The gunner will observe the beaten zone and make adjustments as necessary to hit the targets.

(d) Upon completion of Task 5, the gunner will await further instructions.

NOTE: On command from the grader, the crew will move the carrier to the third predetermined firing location, load one 28-round belt, and conduct Task 6.

(6) *Task 6, Engage a Stationary and a Moving Target From a Mounted Stationary Firing Position.*

(a) From the third predetermined firing location, the gunner will engage one 600-meter personnel target and one 800-meter moving vehicle target from a stationary firing position.

(b) The gunner will use a 5- to 7-round burst for this engagement.

(c) The gunner will observe the beaten zone and make adjustments as necessary to hit the targets.

(d) Upon completion of Task 6, the gunner will await further instructions.

NOTE: From the same firing location as Task 6, the crew will be placed in a chemical environment and be required to go to MOPP4.

(7) *Task 7, React in Chemical Environment.*

(a) Upon command, the crew will be required to react to a chemical agent.

(b) Upon completion of Task 7, the gunner will await further instructions.

NOTE: To accomplish Task 8 through Task 10, the gunner will load one 84-round belt of ammunition.

(8) *Task 8, Engage Stationary Target From a Mounted Stationary Firing Position While in MOPP4.*

(a) From the same firing location as Task 6, the gunner will engage a stationary target at a range of 500 meters from a mounted stationary firing position while in MOPP4.

(b) The gunner will use a 5- to 7-round burst for this engagement.

(c) The gunner will observe the beaten zone and make adjustments as necessary to hit the target.

(d) Upon completion of Task 8, the gunner will await further instructions.

(9) *Task 9, Engage Moving and Stationary Targets From a Mounted Stationary Firing Position While in MOPP4.*

(a) From the same firing location, the gunner will engage one 800-meter moving vehicle target and personnel targets at 1,000 meters.

(b) The gunner will use a 5- to 7-round burst for this engagement.

(c) The gunner will observe the beaten zone and make adjustments as necessary to hit the targets.

(d) Upon completion of Task 9, the gunner will await further instructions.

(10) *Task 10, Engage Multiple Stationary Targets in a Mounted Stationary Firing Position While in MOPP4.*

(a) From the same firing location, the gunner will engage one 300-meter personnel target and two stationary vehicle targets at ranges of 500 and 700 meters.

(b) The gunner will use a 5- to 7-round burst for this engagement.

(c) The gunner will observe the beaten zone and make necessary adjustments to hit the target.

(d) Upon completion of firing Task 10, the gunner will clear his machine gun, have it inspected by the safety officer, move from the firing line, and turn in any excess ammunition. Then the crew will be critiqued.

TASK	CONDITIONS TARGET/SITUATION	AMMO	STANDARD
1. Conduct prefire inspection.	At a stationary position given a 450-meter stationary target, headspace and timing gauge, unit's organic vehicle, and M2 machine gun.	7-round belt of 12.7-mm.	Conduct prefire inspection and fire 7 rounds to confirm operation of machine gun.
2. Engage stationary target from a stationary firing position.	Gunner is in a stationary mounted firing position and engages a 450-meter stationary personnel target. Gunner must use 5- to 7-round bursts for this engagement.	14 rounds of 12.7-mm.	Gunner must impact on target.
3. Engage stationary target from a stationary firing position.	Gunner is in a stationary mounted firing position and engages a 850-meter stationary vehicle. Gunner must use 5- to 7-round bursts for this engagement.	14 rounds of 12.7-mm.	Gunner must impact on target.
4. Engage moving and stationary targets from another stationary firing position.	Gunner is in a stationary mounted firing position and engages a moving vehicle at 800 meters and stationary vehicle at 1,000 meters. Gunner must use 5- to 7-round bursts for this engagement.	28-round belt of 12.7-mm.	Gunner must impact on each target.
5. Engage stationary targets while firing from a moving vehicle.	While the gunner's vehicle is moving, the gunner engages stationary vehicles at 300 and 500 meters. gunner must use 5- to 7-round bursts for this engagement.	28-round belt of 12.7-mm.	Gunner must impact on each target.
6. Engages a stationary and moving target from a stationary firing position.	Gunner is in a stationary firing position and engages a 600-meter personnel and 800-meter moving vehicle targets. gunner will use 5- to 7-round bursts for this engagement.	28-round belt of 12.7-mm.	Gunner must impact on each target.
7. React to chemical agent.	While in a stationary position, given protective mask and protective clothing, crew must react to chemical agent.	N/A	In accordance with FM 3-3.
8. Engage stationary target from a stationary firing position while in an upgraded NBC posture.	Gunner is in a stationary firing position and engages a 500-meter vehicle target. gunner will use 5- to 7-round bursts for this engagement.	14 rounds of 12.7-mm.	Gunner must impact on target.

Figure C-12. Mounted Firing Exercise Table VI.

TASK	CONDITIONS TARGET/SITUATION	AMMO	STANDARD
9. Engage moving and stationary targets while in a stationary firing position in an upgraded NBC posture.	Gunner will engage 800-meter moving vehicle target and personnel targets at 1,000 meters. Gunner will use 5- to 7-round bursts for this engagement.	28 rounds of 12.7-mm.	Gunner must impact on targets.
10. Engage multiple stationary targets while in a stationary firing position in an upgraded NBC posture.	Gunner will engage 300-meter personnel targets, 500-and 700-meter vehicle targets. Gunner will use 5- to 7-round bursts for this engagement.	42 rounds of 12.7-mm.	Gunner must impact on each target.

Figure C-12. Mounted Firing Exercise Table VI, continued.

e. **Scoring Procedures.** The mounted firing exercise is graded on a Go/No Go basis. Commanders may increase the difficulty of any or all tasks to align the exercise with the unit's mission.

C-9. PREDETERMINED FIRING EXERCISE

The predetermined firing exercise is for the gun crew that has demonstrated proficiency during the basic phase of gunnery. Emphasis will be on developing range cards and confirming range-card data during day and night firing.

a. **Objectives.** The objective of this training is to reinforce what was developed in the fundamental gunnery phases. It is designed to increase the effectiveness of the M2 MG crew by building their confidence to quickly and accurately deliver a large volume of fire on a prescribed target.

b. **Organization.** The unit is assembled in the bleachers, given instructions, and briefed on training that will be conducted while they are on the range. After briefing, they will be organized into gun crews and moved to firing lanes. Lanes will be used IAW local range policies.

c. **Ammunition.** This exercise requires 168 rounds of 12.7-mm linked ammunition. The gunner is allotted two bursts per target during the day phase and one burst per target during the night phase. Each gunner will be issued two belts of ammunition; one 112-round belt for the day phase and one 56-round belt for the night phase.

d **Firing Sequence.** The sequence of firing will be conducted IAW Firing Table VII (Figure C-13, page 33). The suggested sequence of firing is as follows:

(1) *Day phase.*

(a) Task 1, Prepare a Range Card. Once the gunner is assigned his firing point, he must prepare a range card for that position. Range cards must be prepared IAW paragraph E-2.

(b) Task 2, Obtain Direction and Elevation Readings for the Final Protective Line. During this task, the gunner is allotted 28 rounds to obtain and record the direction and elevation reading of his FPL.

(c) Task 3, Obtain Direction and Elevation Readings for Point Targets. The gunner will be required to obtain and record direction and elevation readings for point targets located at 400, 600, 800, and 1,000 meters. He is allotted 56 rounds for this task.

(d) Task 4, Obtain Direction and Elevation Readings for Linear Targets. The gunner will be required to obtain and record direction and elevation readings for linear targets located at 600 and 800 meters. He is allotted 28 rounds for this task.

(2) *Night phase.*

NOTE: Each crew is scored as a group in the night phase. (The day phase is not scored.) The crew applies the data obtained during the day and engages their targets. Each crew receives 10 points for each target engagement. A minimum of 40 out of a possible 70 is required. This exercise is not a requirement for qualification; however, commanders can use this training to test their gun crews' proficiency.

(a) Task 5, Engage Point Targets Using Range-Card Data. The gunner must engage point targets located at 400, 600, 800, and 1,000 meters using range-card data. He is allotted 28 rounds for this task. The grader will announce the sequence of engagements.

(b) Task 6, Engage Area Targets Using Range-Card Data. The gunner must engage linear targets located at 600 and 800 meters using range-card data. He is allotted 14 rounds for this task. The grader will announce the sequence of engagements.

(c) Task 7, Fire Final Protective Line. The gunner will fire his FPL to obtain grazing fire. He is allotted 14 rounds for this task.

e. **Conduct of Firing.** The gunner, assistant, and leader will prepare a range card for that position. Once complete, each crew will be given 168 rounds as prescribed in a predetermined firing table.

(1) Each gunner initially lays on his target by using the dry-fire technique. Each crew is issued 168 rounds of ammunition, and the gunner is ordered to load by the group NCO. When all the gunners of a group are ready, the NCO announces, "Up," to the officer in charge.

(2) When all groups are ready to fire, the OIC announces, "Give me an 'Up' when you have engaged all targets and have obtained the correct data to all targets. You are clear to fire."

(3) When the gunner has correctly engaged his target (FPL), the leader records the information from the T&E mechanism and traversing bar onto a range card. Then, the assistant gunner becomes the gunner, the gunner becomes the leader, and the leader becomes the assistant gunner.

(4) As each member of the crew becomes the gunner, he fires at a different preselected target (order number 2, a linear target; order number 3, a point target).

(5) After each crew member has been a gunner, assistant gunner, and leader and all data on the three targets have been obtained, the group NCO clears and checks the machine guns of his group and announces to the OIC, "Group cleared and checked."

TASK	CONDITIONS TARGET/SITUATION	AMMO	STANDARD
1. Prepare a range card for the M2 machine gun.	The gunner is given a range card, a selected firing position, M2 machine gun, M3 tripod, and silhouette targets located from 400 to 1,000 meters.	N/A	Gunner must prepare a range card IAW Appendix E, FM 23-65.
2. Determine and record direction and elevation for final protective line.	The gunner is allotted 12.7-mm linked ammo, and a sector of fire with limits.	28 rounds of 12.7-mm.	Gunner must record the direction and elevation for his range card.
3. Determine and record direction and elevation for point targets.	The gunner is allotted 12.7-mm linked ammo, four E-type silhouettes located at 400, 600, 800, and 1,000 meters.	56 rounds of 12.7-mm.	Gunner must impact one burst on each target.
4. Determine and record direction and elevation for area targets.	The gunner is allotted 12.7-mm linked ammo, two E-type silhouettes located at 600 and 800 meters.	28 rounds of 12.7-mm.	Gunner must impact one burst on each target.
5. Engage point targets using range card data.	The gunner is allotted 12.7-mm linked ammo, the same firing position, and his prepared range card.	28 rounds of 12.7-mm.	Gunner must impact one burst on each target.

Figure C-13. Predetermined Firing Table VII.

TASK	CONDITIONS TARGET/SITUATION	AMMO	STANDARD
6. Engage area targets using range card data.	The gunner is allotted 12.7-mm linked ammo, and his prepared range card.	14 rounds of 12.7-mm.	Gunner must impact one burst on each target.
7. Fire final protective line.	The gunner is allotted 12.7-mm linked ammo, and his prepared range card.	14 rounds of 12.7-mm.	Gunner must obtain grazing fire when firing his FPL.

Figure C-13. Predetermined Firing Table VII, continued.

APPENDIX D

FIGHTING POSITIONS

Fighting positions are stable platforms from which a gunner can engage the enemy. Fighting positions are dug as often as possible, but for the most part only when a unit is in the defense and has the time. This appendix discusses the construction of only two fighting positions: the one-, two-, or three-man, tripod-mounted position; and the M63 antiaircraft emplacement.

D-1. CONSTRUCTION CONSIDERATIONS

When constructing a fighting position, the leader and gunner should consider factors that affect the position, such as cover, concealment, fields of fire, size, and improvements.

a. The cover in a machine gun fighting position protects the gun crew from frontal small-arms fire and from fragments of high explosive shells impacting within 3 to 5 meters of the position. The frontal parapet must be at least one M16 rifle length thick and high enough to hide the helmets of the soldiers in the position. Overhead cover built out of sandbags stacked on logs will protect from shell fragments. The logs should be at least 6 inches thick, with at least two layers of sandbags over them (Figure D-1).

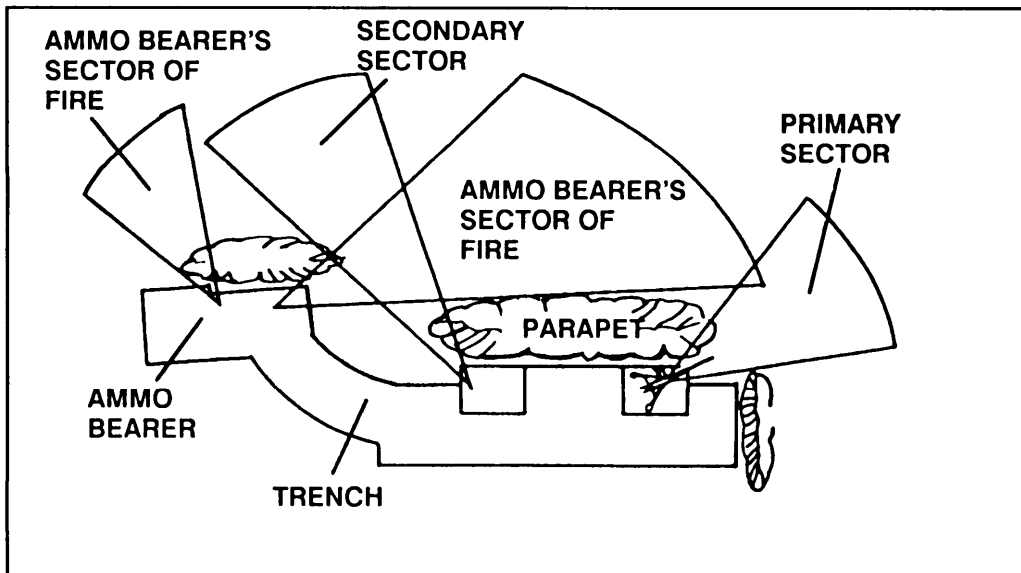

Figure D-1. Three-man fighting position.

b. Concealment hides the machine gun fighting position from direct observation by the enemy, who will make every attempt to locate and destroy heavy machine gun positions early in the battle. The position must be made to blend with its surroundings with both natural and man-made camouflage. Excess dirt from the initial digging should be moved away from the position, and the sod used to re-cover the overhead protection. From the enemy side, the position should not be visible at 35 meters or less (hand grenade range). It should never be obvious even at close range. Use sod or dampen the ground in front of the muzzle to reduce the dust cloud caused by firing. Consider what the position looks like from the air and camouflage it to blend with the surrounding terrain.

c. Selective clearing that does not destroy natural camouflage may be necessary to provide good observation and fields of fire in both primary and secondary sectors of fire.

d. The position should be armpit deep, be wide enough to allow two soldiers with load-bearing equipment to move freely, and have two distinct firing platforms.

e. Improvements to the position may include a grenade sump, a sloping floor with shallow trench for drainage, and a rear parapet for protection against shell fragments and small-arms fire from the rear (other friendly positions or supporting fire from armored personnel carriers).

D-2. CONSTRUCTION OF A TRIPOD-MOUNTED POSITION

After being assigned a sector of fire with an FPL or a PDF, the gun crew begins constructing the fighting position. The tripod is placed in position first and marked so that the weapon will be pointed in the general direction of the target area. A preliminary sketched range card is drawn to show the limits of the sector. The gun crew then outlines the shape of the platform and hole to include the area for the frontal cover in the ground (Figure D-2). The crew then starts digging out the platforms. When they get about 4 to 6 inches deep, the MG is put in place to cover the primary sector of fire until construction is complete.

a. When assigned an FPL, emplace the gun by locking the traversing slide to the extreme left or right of the traversing bar, depending on which side of the primary sector the FPL is on. Align the barrel on the FPL by shifting the tripod.

NOTE: No direction entry is needed in the data section of the range card for the FPL.

b. When assigned a PDF, emplace the gun by locking the traversing slide at the center of the traversing bar. Shift the tripod and gun until the

barrel is aimed at the center of the sector. Check coverage of the sector limits by traversing the gun fully left and right.

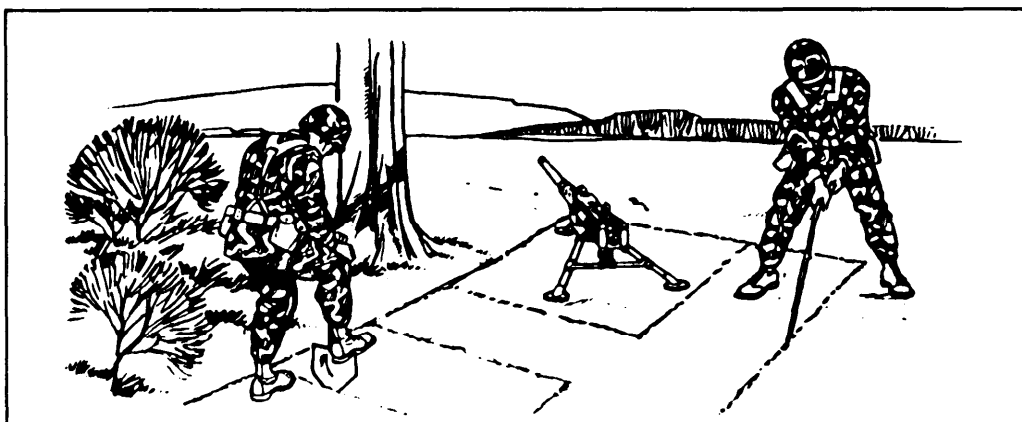

Figure D-2. Planning the fighting position.

NOTE: In the data section of the range card, record the direction and elevation data of the PDF and the sector limits from the T&E mechanism.

c. The crew digging the hole uses the dug-up dirt to build up the cover – first for frontal cover and then for flank and rear cover. They dig the hole deep enough to protect the crew and still let the gunner shoot with comfort (usually about armpit deep) (Figure D-3). They fix the tripod legs in place by digging, sandbagging, or staking them down. This will ensure that the gun does not shift during firing, which would render the range card data useless.

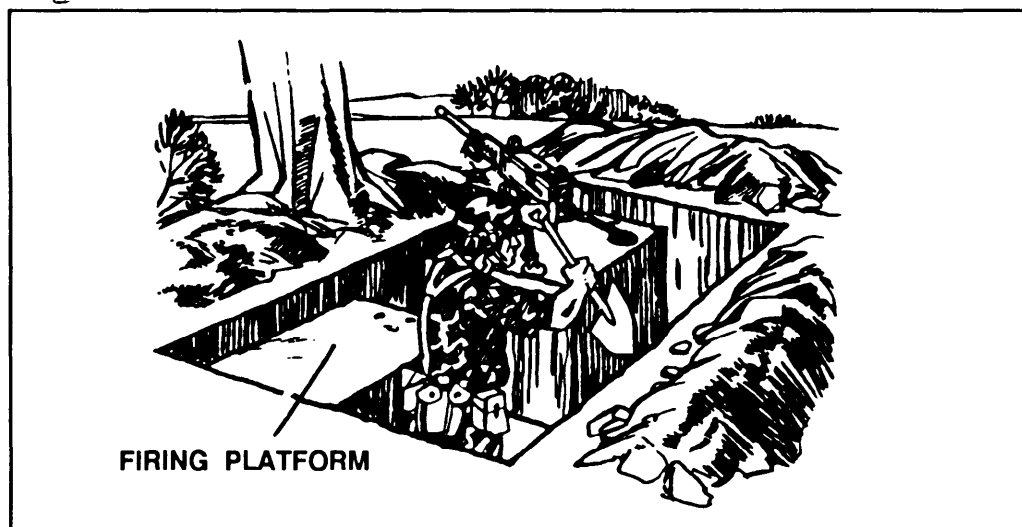

Figure D-3. Digging the fighting position.

(1) The crew digs three trench-shaped grenade sumps at various points where the crew can kick grenades into them (Figure D-4).

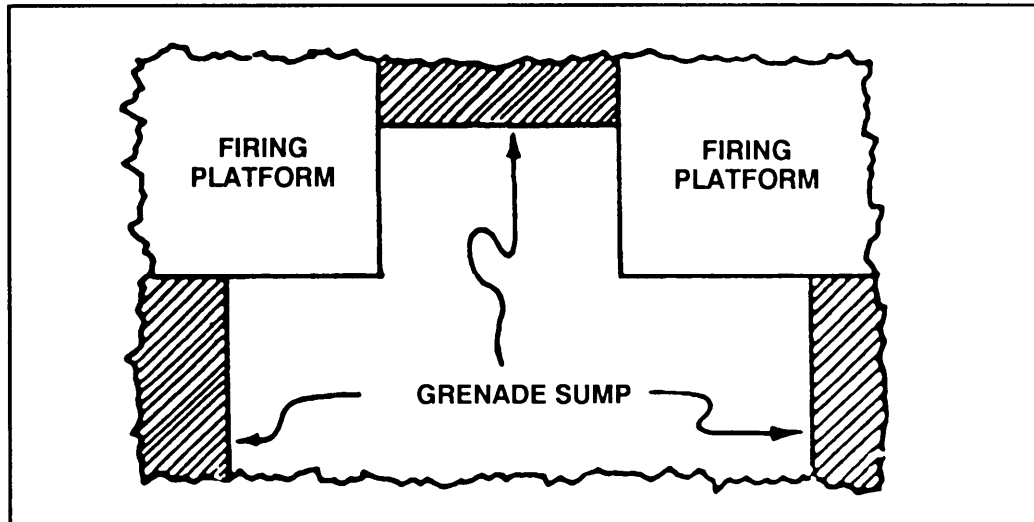

Figure D-4. Digging grenade sumps.

(2) When a position does not have a secondary sector of fire, the crew digs only half of the position (Figure D-5).

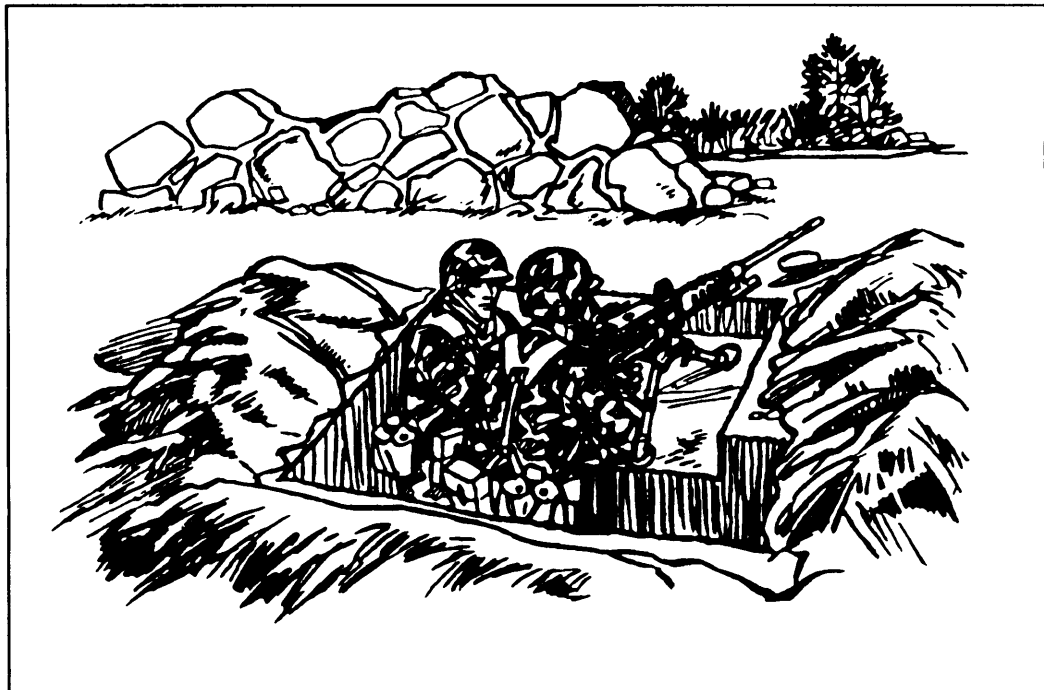

Figure D-5. Half of a position.

(3) When a position has both a primary and secondary sector, the crew prepares two firing platforms. The crew prepares overhead cover for a machine gun position like that of a two-man small arms fighting position. Time and material permitting, overhead cover should extend to cover the firing platforms (Figure D-6). Failure to properly construct overhead cover can result in reduced fields of fire, inability to mount NVDs, or problems in reloading. Proper construction of overhead cover is critical to survival.

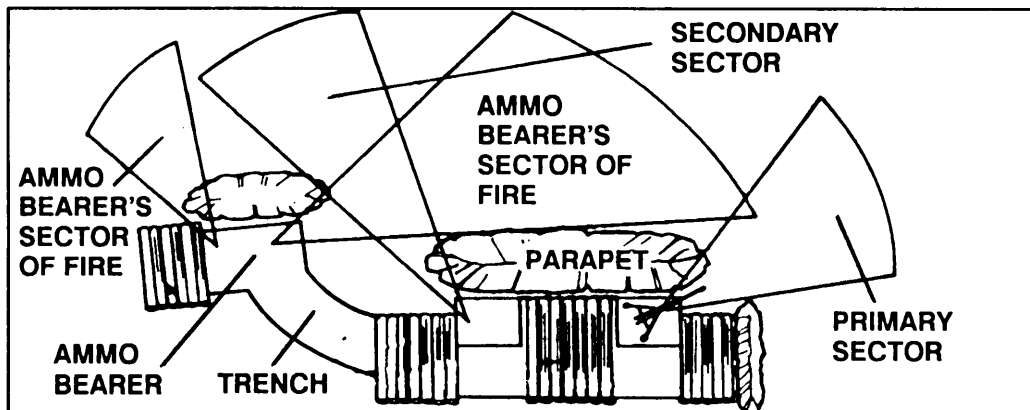

Figure D-6. Two firing platforms with overhead cover.

(4) When there is a three-man crew for the machine gun, the ammunition bearer digs a one-man fighting position to the flank of the gun position so that he can see and shoot to the oblique. This will allow him to cover the front of the machine gun's position (Figure D-7).

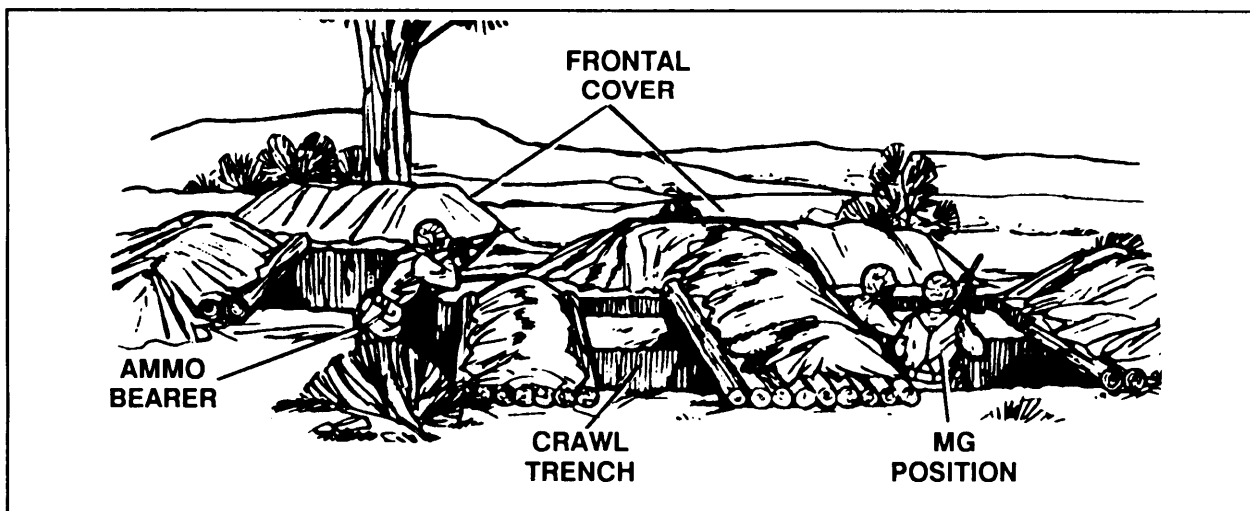

Figure D-7. Ammo bearer covering the front.

D-3. CONSTRUCTION OF AN ANTI-AIRCRAFT EMPLACEMENT

Place the machine gun on the M63 mount alongside the designated location of the gun position. If needed, it can fire at any time during the construction process. Construct a circular position, with sufficient room to traverse the gun 360 degrees (normally, three and a half M16 lengths in diameter and one M16 length deep). Use the dirt dug out of the circular hole to construct a wall of sandbags around the position. Using sandbags, build a stable platform for the mount. Stake down the legs of the mount and place sandbags over them. This will prevent the mount from tipping backward when low-level targets are engaged. Include the M63-mounted machine gun's fire in the plan for defending the unit against ground attack (Figure D-8).

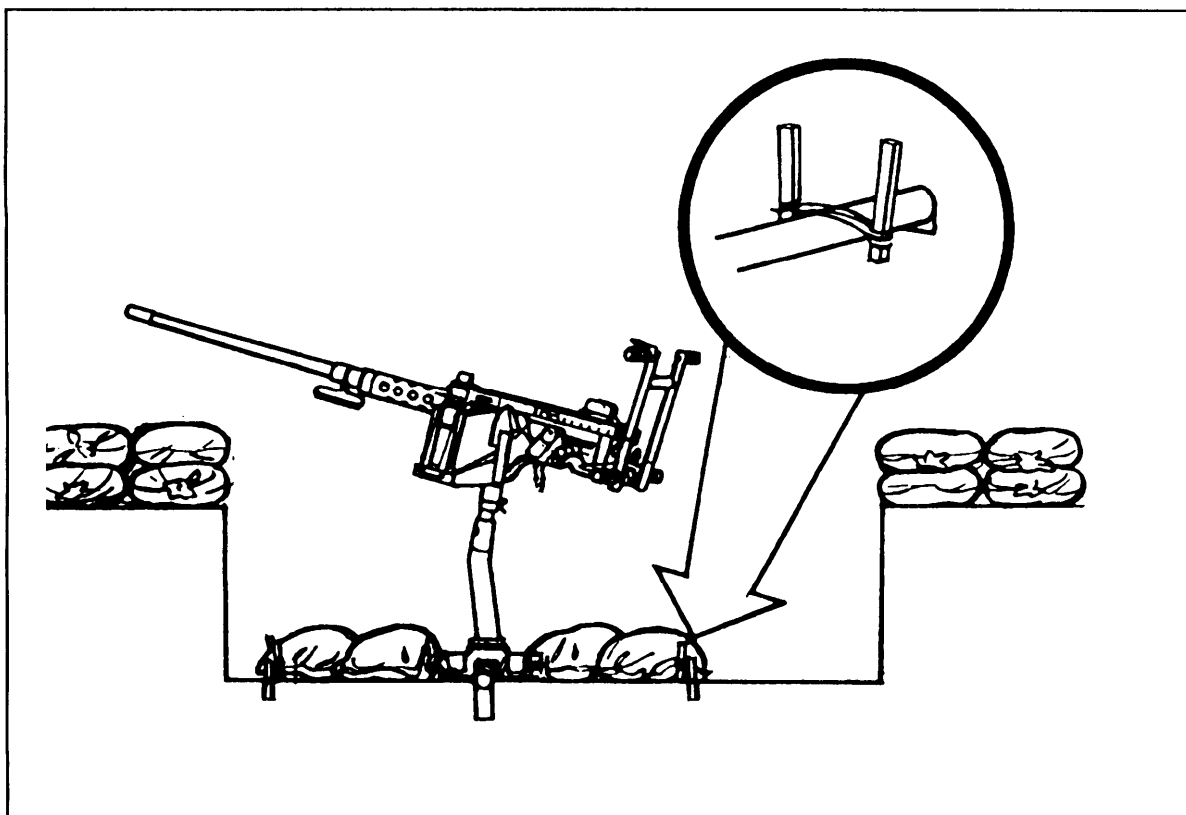

Figure D-8. Open pit-type anti-aircraft position.

APPENDIX E

RANGE CARDS

A range card is a sketch or diagram of the terrain that a weapon is assigned to cover by fire. It shows possible target areas and terrain features plotted in relation to a firing position. The information on a range card is used for planning and controlling fire, for rapidly detecting and engaging targets, and for orienting replacement personnel or units. Therefore DA Form 5517-R, should be used to record the information.

E-1. RANGE CARD SECTIONS

Each machine gunner normally prepares range cards for his fighting position. He prepares one for each primary, alternate, and supplementary position designated in the defense and for any static position when enemy contact is possible; for example, a position in an assembly area. Each range card contains, as a minimum, the following information:

- a. The symbol for the weapon covering the sector.
- b. The azimuth (degrees) and distances (meters) of the firing position from an easily recognizable terrain feature. (This serves as an easy reference to locate the firing position.) If there is no easily recognizable terrain feature, an eight-digit grid may be used.
- c. The boundaries of the area assigned to be covered by observation and fire.
- d. Areas where targets are likely to appear (engagement areas) and the range, azimuth, and elevation to them from the firing position.
- e. Dead space (areas that cannot be observed or covered by fire).
- f. The direction of magnetic north when the range card is properly oriented.
- g. Identification data.
 - Unit designation (no higher than company).
 - Time and date of preparation.
 - Firing position (primary, alternate, or supplementary).

E-2. PREPARATION

The following steps are taken to prepare a range card. (See Figure E-1, page E-3, for an example of a completed range card).

- a. Draw the symbol for the MG in the lower center of the range card.

b. Show the sector of fire by drawing solid lines from the weapon symbol to the left and right limits. Sketch any easily recognizable terrain features that can be used to identify the sector. In the data section, indicate the magnetic azimuth and the range to the far limits of the sectors of fire.

NOTE: The left and right limits are labeled one and two, respectively, in the sector sketch and a circle drawn around each number. The left and right limits should be the first items drawn and labeled in the sector sketch and the data section of the range card. (The azimuth and range are not placed on the solid lines for left or right limit.)

c. Place target reference points at the location designated by the platoon leader or unit SOP, and at any other locations where a target is likely to appear. Number each TRP and likely target locations in the sketch section of the range card.

d. Draw a maximum engagement line across the sector of fire for the MG. These lines depict the maximum ranges at which a target can be effectively engaged.

e. Show dead space or areas where targets cannot be engaged with direct fire by drawing diagonal lines across the areas and writing the words DEAD SPACE.

f. Draw a magnetic north arrow on the range card to orient it with the terrain. Then add identification data – unit designation (no higher than company level), time and date of preparation, and type of position (primary, alternate, or supplementary).

g. Enter the information for the weapon reference point in the remarks block on the range card.

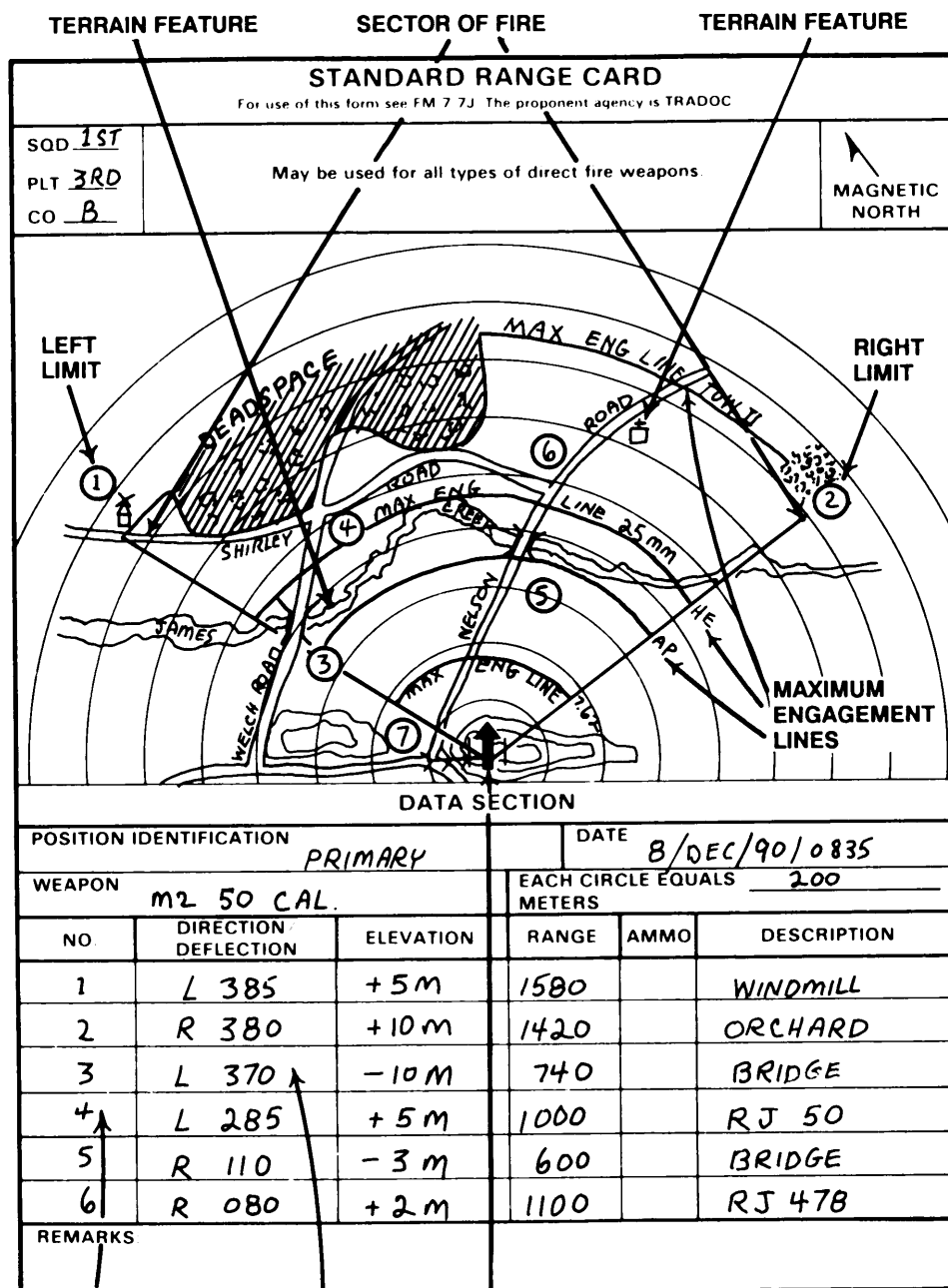

DA FORM 5517-R, FEB 86

TERRAIN
FEATURES

T&E DATA SYMBOL FOR MG

Figure E-1. Range card.

APPENDIX F

AERIAL DEFENSE

The two methods for defending against aerial attacks are passive air defense and active air defense. Passive measures are taken to avoid air detection; active measures combat air attacks.

F-1. PASSIVE AIR DEFENSE

Passive air defense measures are a first line of defense. They include troop or vehicle dispersion, concealment and camouflage, and observation and reporting. Attack avoidance is based on the reasoning that what can be seen from the air can be destroyed and what cannot be seen will probably not be attacked.

F-2. ACTIVE AIR DEFENSE

Active air defense comes into play when a unit has been detected by hostile aircraft or when ordered to interdict hostile aircraft. Volume of fire is the key to its effectiveness. Because the action is so fast, the response must be coordinated and tightly controlled, usually at platoon level. At company level, too many are involved, making response time too slow. At section and squad level, too few are involved to achieve the volume of fire needed for an effective defense.

NOTE: All aircraft engagement firing is done at the cyclic rate.

F-3. AERIAL ENGAGEMENT

In engaging aerial targets, there are two requirements that must be considered: lead and line. Superelevation (compensation made for the pull of gravity on the projectile) is another consideration for some weapons, but the caliber .50 MG projectile is basically flat out to 800 meters. Therefore the gunner does not have to worry about it. He can instead observe the tracers crossing the target course line and make the required adjustment from them.

a. **Lead.** Leading the aircraft is the compensation made for its speed when aiming the weapon so the projectile and the aircraft will arrive at the same spot at the same time. The required lead for a given aircraft is always calculated as a certain number of lengths of that aircraft. A high performance aircraft will need a greater lead factor than a slow one. The

fuselage in the front of the aircraft.

(1) If the gunner is able to track an aircraft and lead the air craft with a constant number of leads, there will be two points along the target course line where he will attain hits. As long as the gunner understands this principle, he can bring effective fire on an aircraft.

(2) There are many different types of hostile aircraft (FM 44-30). To simplify things for the gunner, all aircraft are classified into two types: high performance and low performance. Any aircraft that has an estimated speed of more than 150 knots is classified as high performance and anything slower is low performance.

b. **Line.** Line is the requirement that the projectile must intersect the target course line of the aircraft. If the projectiles do not pass through this target course line, the aircraft cannot be engaged.

F-4. FLY-THROUGH TECHNIQUE

As an aerial target moves along its target course line, the lead required to engage the target changes because the range and angle between the aircraft and the gun position are changing. The lead required increases from the initial sighting (A in Figure F-1) to midpoint (B in Figure F-1). The required lead is at its maximum at midpoint.

a. As the aircraft moves beyond the midpoint on the target course line, the lead needed begins to decrease. Therefore, by leading an aerial target by less than the maximum required lead, there will be two points along the target course line where the constant lead will be the correct lead and the aircraft will fly through the projectiles.

b. In instructing the fly-through method of engagement, do not teach the gunners to bring continuous fire from points A through E, teach them to bring fire at points A through B and again before point D through the second fly through. As the gunner becomes proficient in this method, he will learn to adjust his lead and bring longer and more accurate fire on the target.

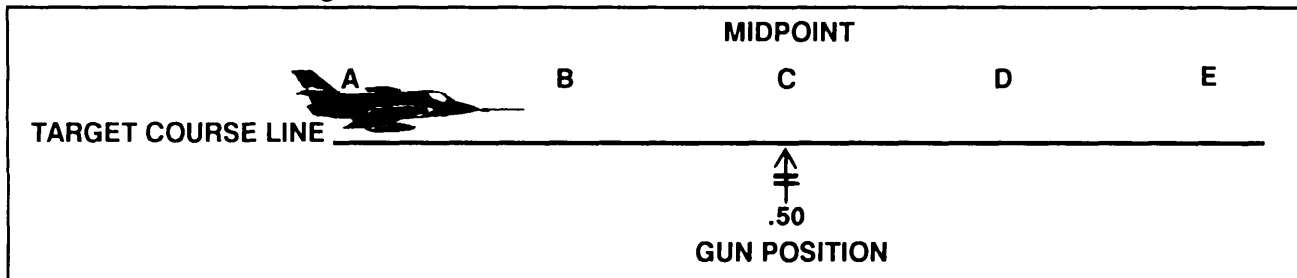

Figure F-1. Aerial target engagement.

GLOSSARY

AAR	after action report
AP	armor piercing
APC	armored personnel carrier
approx	approximately
attn	attention
ba	battery
BFA	blank firing attachment
BFV	Bradley fighting vehicle
BMP	Soviet fighting vehicle
cal	caliber
cdr	commander
CLP	cleaner, lubricant, and preservative
CVKI	combat vehicle kill indicator
DA	Department of the Army
FEBA	forward edge of the battle area
FM	field manual
FPF	final protective fires
FPL	final protective line
FSN	federal stock number
FTX	field training exercise
GA	Georgia
HB	heavy barrel
HMMWV	high-mobility, multi-purpose, wheeled vehicle
IAW	in accordance with
IN	infantry
LFX	live-fire exercise
LSA	semifluid lubricating oil
LTA	local training area
m	meter
METL	mission-essential task list

MG	machine gun
MILES	multiple integrated laser engagement system
mm	millimeter
MOPP	mission-oriented protection posture
mph	miles per hour
MOUT	military operations on urbanized terrain
MTA	major training area
MTP	mission training plan
NBC	nuclear, biological, and chemical
NCO	noncommissioned officer
NCOES	noncommissioned officer education system
NCOIC	noncommissioned officer in charge
NSN	national stock number
NVD	night vision device
OIC	officer in charge
PDF	principal direction of fire
PL-M	lubricating oil, general purpose
PL-S	lubricating oil, special purpose
PMI	preliminary marksmanship instruction
POI	program of instruction
RABA	recoil amplifier barrel assembly
RBC	rifle bore cleaner
SM	soldiers manual
SMCT	soldiers manual of common tasks
SOP	standing operating procedure
SRTA	short-range training ammunition
SRTA-T	short-range training ammunition-tracer
STP	soldiers training publication
STX	situational training exercise
T&E	traversing and elevating
TM	technical manual
TRADOC	Training and Doctrine Command
TRP	target reference point

US..... United States

v volt

REFERENCES

Sources Used

These are the sources quoted or paraphrased in this publication.

- | | |
|-------------------|--|
| FM 3-5. | NBC Decontamination. 24 June 1985. |
| FM 25-7. | Training Ranges. 16 September 1985. |
| FM 44-30. | Visual Aircraft Recognition.
28 October 1986. |
| STP 21-24-SMCT. | Soldiers Manual of Common Tasks,
Skill Levels 2/3/4. 10 January 1989. |
| TM 9-1005-213-10. | Operator's Manual: Machine Gun,
Cal.50,Browning, M2, Heavy Barrel.
12 July 1968. |
| TM 9-1300-200. | Ammunition General. 3 October 1969. |
| TM 9-1300-206. | Ammunition and Explosive Standards.
30 August 1973. |

Documents Needed

These documents must be available to the intended users of this publication.

- | | |
|-----------------|--|
| DA Form 2404. | Equipment Inspection and Maintenance
Worksheet. April 1979. |
| DA Form 5517-R. | Standard Range Card. February 1986. |
| DA Form 7007-R. | Machine Gun Scorecard for M2. June 1991. |

MACHINE GUN SCORECARD FOR M2										See back of this form for instructions.			
For use of this form, see FM 23-65; the proponent agency is TRADOC.													
NAME:										DATE:			
SSAN:										UNIT:			
SSAN:										LANE:			
TSK	TABLE I			TABLE II			TABLE III			TABLE IV			
	Range (Meters)	HIT	PTS	RANGE (Meters)	TIME	HIT	PTS	BON	RANGE (Meters)	TIME	HIT	PTS	BON
1	10	No Score		550	None				550	None			
2	10	No Score		800	20 Sec				800	20 Sec			
3	10	No Score		400	20 Sec				400	20 Sec			
4	10	No Score		700	25 Sec				700	25 Sec			
5	10			1,000	25 Sec				1,000	25 Sec			
6	10			400					400				
				700	35 Sec				700	35 Sec			
7	10			550					550				
				800	35 Sec				800	35 Sec			
8				400					400				
				550	45 Sec				550	45 Sec			
				1,000					1,000				
TOTAL													
										Grader:			
										Rating:			
										Rating:			
										Rating:			

TABLES	I	II	III	IV	TOTAL SCORE

OIC Signature:	Grader:
Rating:	

AUTHORITY: 10USC30129(g) Executive Order 9397. PRINCIPAL PURPOSE(S): Records individual's performance on record fire range. ROUTINE USE(S): Evaluation of individual's proficiency and basis for determination of award of proficiency badge; SSN is used for positive identification purposes only. MANDATORY OR VOLUNTARY DISCLOSURE AND EFFECT ON INDIVIDUAL NOT PROVIDING INFORMATION: Voluntary, individuals not providing information cannot be rated/scored on a mass basis.

DA Form 7007-R, Jun 91 Replaces DA Form 3867-R, Jun 72, which is obsolete.

The following procedure will be used to fill out the scorecard.

1. **NAME:** Enter last name , first name, and middle initial.
2. **SSN:** Enter gunner's social security number.
3. **UNIT:** Enter unit designation.
4. **DATE:** Enter date of firing.
5. **LANE:** Enter the lane number for the firing point of your gunner.
6. **HIT:** When firing Table I, enter the number of rounds impacting within the scoring space in task numbers 5, 6, and 7. For Tables II, III, and IV, enter an X when target is hit.
7. **POINTS:** Enter 1 point for each round impacting within the scoring space in task numbers 5, 6, and 7 in Table I. Gunners will receive 1 point for each target hit in Tables II, III, and IV.
8. **BONUS:** Entry is used only for Tables II, III, and IV. Two bonus points are awarded when gunner hits the target on initial burst of each target exposure.
9. **TOTAL SCORE:** Enter the total of combined hits, points, and bonus scores.

NOTE: It is possible that a gunner may score the required points outlined for qualification. However the gunner must also score 70 percent on each firing table before he is considered a qualified gunner.

MAXIMUM	218
EXPERT	196-218
GUNNER FIRST CLASS	174-195
GUNNER SECOND CLASS	153-173
UNQUALIFIED	152 and below

INDEX

A

adjustment of fire methods

- aiming point, 5-18 (illus), 6-24
- mil relation, 5-17 (illus), 6-24
- observation, 5-16, 6-23

advanced gunnery

- mounted, 5-45, C-26 thru C-31
- mounted NBC, 5-45, C-26 thru C-31
- predetermined firing, 5-45, C-31 thru C-34
- tracking and leading, 5-42 thru 5-44

aerial defense

- active, F-1
- engagements, F-1, F-2
- passive, F-1
- techniques, F-3

ammunition, 1-17 (illus)

- ballistic data, 1-18 (illus)
- care, 1-19
- classification, 1-17, 1-18
- penetration data, 1-19, 1-20

antiaircraft gunnery, 6-25, 6-26

- position, D-6 (illus)

AN/TVS-5 night sight

- dismounting 5-41
- installing sight to mount, 5-39
- mounting, 5-38
- zeroing, 5-40

application of fire, 6-22, 6-23 (illus)

assembly, general, 2-12

- backplate group, 2-16
- barrel, 2-17
- barrel buffer assembly, 2-13
- barrel buffer body group, 2-13
- barrel buffer group, 2-14
- barrel extension group, 2-14
- bolt, 2-14
- bolt stud, 2-15
- driving spring rod group, 2-16
- function check, 2-17

B-C

beaten zone, 6-3

classes of fire, with respect to –

- ground, 6-3, 6-4 (illus)
- grazing tire

- plunging fire
- gun, 6-6, 6-7 (illus)
- fixed fire
- free gun
- searching fire
- swinging traverse
- traversing fire
- traversing and searching fire
- target, 6-4, 6-5 (illus)
- enfilade
- flanking
- frontal
- oblique

cleaning the weapon, 2-9, 2-10

clearing the weapon, 2-1 (illus)

cone of fire, 6-2, 6-3 (illus)

crews

- duties, 5-23, 5-32
- equipment, 5-23
- exercises, 5-22
- gun placement, 5-26
- inspection, 5-24
- positions, 5-23
- relocating gun, 5-32 thru 5-35 (illus)

cycle of functioning

- cambering, 3-6 (illus)
- cocking 3-11
- ejecting, 3-10
- extracting 3-10
- feeding 3-4 (illus), 3-5 (illus), 3-6 (illus), 3-11
- firing 3-7, 3-8 (illus)
- locking, 3-6, 3-7 (illus)
- unlocking 3-8, 3-9 (illus), 3-10 (illus)

D-E

defilade positions

- full, 6-18
- laying methods, 6-20, 6-21
- partial, 6-18, 6-19

description, 1-5 (illus)

- components, 1-8, 1-9 (illus)
- front sight, 1-7 (illus)
- general data, 1-7
- rear sight, 1-6 (illus)

destruction procedures

ammunition, 4-5
 antiaircraft mount, 4-5
 burning, 4-6
 disposal, 4-6
 gun, 4-5
 spare parts, 4-5
 tripod mount, 4-5

devices, training

M19 BFA, B-1 (illus)
 M3 RABA, B-8 (illus)
 MILES, B-2 thru B-6
 sighting bar, B-6, B-7 (illus)
 SRTA, B-7

disassembly, general

backplate group, 2-4
 barrel buffer assembly, 2-9
 barrel buffer body group, 2-8
 barrel extension group, 2-8
 barrel group, 2-2
 bolt group, 2-7
 bolt stud, 2-6
 driving spring rod assembly, 2-5
 receiver group, 2-7 (illus)

dry fire

range setting and laying, 5-8
 sighting and aiming, 5-6, 5-7
 traversing and elevating, 5-8 thru 5-12

elevation, setting, 5-37

F-I

fighting positions, construction of,

antiaircraft, D-6 (illus)
 three-man, D-1 (illus)
 tripod-mounted, D-2 thru D-5 (illus)

final protective fires, 6-21**fire commands**

elements of initial command
 alert, 5-19
 command to open fire, 5-21
 description, 5-20
 direction, 5-19
 method of fire, 5-21
 range, 5-21

subsequent commands, 5-22

fire control methods, 6-8,6-28**firing exercises**

mounted, C-26 thru C-31
 NBC, C-14 thru C-17
 night-fire, C-17 thru C-20

predetermined, C-31 thru C-34

qualifications, C-21

scorecard, C-22, C-23 (illus)

ten-meter, C-5 thru C-11

transition, C-11 thru C-14

firing positions

antiaircraft, 5-5, 5-6 (illus)

prone, 5-3 (illus)

sitting, 5-3 (illus)

standing, 5-4 (illus)

vehicular, 5-5 (illus)

firing tables

I, C-5, C-6

II, C-13, C-14

III, C-16, C-17

IV, C-20

VI, C-30, C-31

VII, C-33, C-34

headspace, 3-12 thru 3-16 (illus)**inspection, 2-10, 2-11**

L

limited visibility

difficulties, 6-26

fire control, 6-28

NBC considerations, 6-29,6-30

preplanned fires, 6-28

target engagement, 6-27

terminology, 6-26, 6-27

loading procedures, 3-1,3-3 (illus)

automatic mode, 3-2

single-shot mode, 3-2

lubrication, 2-11

M

maintenance, 2-10

NBC conditions, 2-12

procedures, 2-12 (illus)

malfunctions, 4-1**marksmanship training**

advanced, 5-41 thru 5-45

basic, 5-36 thru 5-41

dry fire, 5-6

fundamentals, 5-3 thru 5-36

phases, 5-2

planning, 5-1

remedial, 5-2

sustainment, 5-2

mounts, ground

accessories, 1-12, 1-13, 1-14
 antiaircraft (M63), 1-9, 1-11 (illus)
 tripod (M3), 1-9, 1-10 (illus)

mounts, vehicular

armored vehicle cupola, 1-14, 1-16 (illus)
 gun cradle (MK64), 1-16 (illus)
 pedestal truck (M31C and M24A2),
 1-14, 1-15 (illus)
 truck (M36), 1-14, 1-15 (illus)

N-O

NBC considerations, 6-29

overhead fire

conditions, 6-16
 gunner's rule, 6-16 (illus)
 leader's rule, 6-17 (illus), 6-18
 minimum clearance, 6-15 (illus)
 precautions, 6-18
 safety angles, 6-15
 terrain, 6-16

R

range card preparation, E-1 thru E-3
 (illus)

range determination

estimating by eye, 5-13, 5-14, 5-15
 firing the gun, 5-15

ranges

multipurpose MG transition, C-1,
 C-2 (illus)
 multipurpose range complex C-24,
 C-25 (illus)
 ten-meter layout, C-3 (illus), C-4

range safety, A-1, A-2, A-3

range setting and laying, 5-8

S

scorecard, C-22, C-23 (illus)

qualifications, C-21
 reproducible form, back of manual

sighting and aiming, 5-6, 5-7 (illus)

sight picture, 5-37

stoppages, 4-1, 4-2 (illus)

immediate action, 4-2, 4-3
 remedial action, 4-32, 4-4 (illus)

T

target engagements

area targets, 6-13, 6-14 (illus)
 deep targets, 6-12
 limited visibility, 6-27
 linear targets, 6-9
 linear targets with depth, 6-10
 NBC considerations, 6-29
 point targets, 6-9

test, fundamental skills, 5-36

timing

field expedient methods, 3-18, 3-19
 gauge, 3-12 (illus)
 procedures, 3-16, 3-17, 3-18 (illus)

training

collective, 1-2
 devices, App B
 initial, 1-1, 1-3
 marksmanship, 5-1 thru 5-45
 safety, 7-1, 7-2, App A
 sustainment, 1-2, 1-3, 1-4 (illus), 5-2
 train the trainer, 1-3, 7-1, 7-2, 7-3

training strategy, 1-1, 1-4 (illus)

trajectory, 6-1, 6-2 (illus)

traversing and elevating 5-8 thru 5-12

direction reading, 5-10
 elevation reading, 5-11
 manipulation exercise, 5-11, 5-12
 zeroing 5-10

U-Z

unloading procedures, 3-3

windage, set, 5-37

zeroing/targeting

AN/TVS-5, 5-38, 5-39, 5-40
 field, 5-38
 ten-meter, 5-36

FM 23-65
19 JUNE 1991

By Order of the Secretary of the Army:

GORDON R. SULLIVAN
General, United States Army
Chief of Staff

Official:

PATRICIA P. HICKERSON
Brigadier General, United States Army
The Adjutant General

DISTRIBUTION:

Active Army, USAR, and ARNG: To be distributed in accordance with DA Form 12-11E, requirements for FM 23-65, Browning Machine Gun Caliber .50 HB, M2 (Qty rqr block no. 0203)